

Thank you for purchasing a Sealey product. Manufactured to a high standard this product will, if used according to these instructions and properly maintained, give you years of trouble free performance.

! **IMPORTANT: PLEASE READ THESE INSTRUCTIONS CAREFULLY. NOTE THE SAFE OPERATIONAL REQUIREMENTS, WARNINGS & CAUTIONS. USE THIS PRODUCT CORRECTLY AND WITH CARE FOR THE PURPOSE FOR WHICH IT IS INTENDED. FAILURE TO DO SO MAY CAUSE DAMAGE AND/OR PERSONAL INJURY AND WILL INVALIDATE THE WARRANTY. PLEASE KEEP INSTRUCTIONS SAFE FOR FUTURE USE.**

1. SAFETY INSTRUCTIONS

1.1 GENERAL SAFETY

- ✓ Familiarise yourself with this products application and limitations, as well as the specific potential hazards peculiar to the press.
- ✓ Maintain the press in good condition (use an authorised service agent).
- ✓ Replace or repair damaged parts. *Use recommended parts only. Non authorised parts may be dangerous and will invalidate the warranty.*
- ✓ Keep the press clean for best and safest performance.
- ✓ Locate the press in a suitable working area for its function, keep area clean, tidy, free from unrelated materials and ensure there is adequate lighting.
- ✓ Ensure the workpiece is correctly secured before operating the press.
- ❑ **WARNING!** Always wear approved eye or face protection when operating the press.
- ✓ Remove ill fitting clothing. Remove ties, watches, rings, loose jewellery and contain long hair.
- ✓ Keep hands and body clear of the work table when operating the press.
- ✓ Maintain correct balance and footing. Ensure the floor is not slippery and wear non slip steel toe-capped shoes/boots.
- ✓ Keep children and unauthorised persons away from the working area.
- x **DO NOT** operate the press if any parts are missing as this may cause failure or possible personal injury.
- x **DO NOT** use to compress springs or any other item that could disengage and cause a potential hazard.
- x **DO NOT** stand directly in front of the loaded press and never leave a loaded press unattended.
- x **DO NOT** force the press to achieve a task it was not designed to perform.
- x **DO NOT** make any modifications to the press.
- x **DO NOT** adjust or tamper with the safety valve.
- x **DO NOT** exceed the rated capacity of the press.
- x **DO NOT** apply off centre loads.
- x **DO NOT** allow the workpiece or the arbor plates to fall from the press working bench.
- x **DO NOT** get the press wet or use in damp or wet locations or areas where there is condensation.
- x **DO NOT** operate the press when you are tired, under the influence of alcohol, drugs or intoxicating medication.
- ✓ When not in use release pressure from the pump and clean the press. Stand or store the arbors in a safe location.
- ❑ **WARNING!** Always position the press against a wall. If the press is situated in the open workshop, it is essential that a guard be placed at the rear of the unit. This will prevent injury to bystanders in the event of the work piece ejecting suddenly.
- ❑ **WARNING!** The warnings, cautions and instructions in this manual cannot cover all possible conditions and situations that may occur. It must be understood by the operator that common sense and caution are factors which cannot be built into this product, but must be applied by the operator.
- ▲ **DANGER!** The press is top heavy. If it requires moving after assembly or for relocation, use suitable slings around the top crossbeam, or lift direct with a forklift with the forks located under the top crossbeam. **DO NOT** use a pallet truck.

2. INTRODUCTION & SPECIFICATIONS

2.1. GENERAL INFORMATION

Steel frame construction with hydraulic pump unit. Sliding hydraulic ram assembly gives 176mm of lateral travel for off-centre pressing applications. Frame head fitted with ram pressure gauge. Supplied with flat pressing plate/V-blocks.

- Model No: YK209F
- Capacity: 20tonne
- Ram Stroke: 180mm
- Ram Ø: 50mm
- Lateral Ram Travel: 176mm
- Max Height Ram to Table: . . . 912mm
- Min Height Ram to Table: . . . 35mm
- Table Aperture: 155mm
- Working Table Depth: 175mm
- Working Table Width: 510mm
- Overall Height: 1619mm
- Weight: 105kg
- Safety Guard (Optional): . . . YKSG20

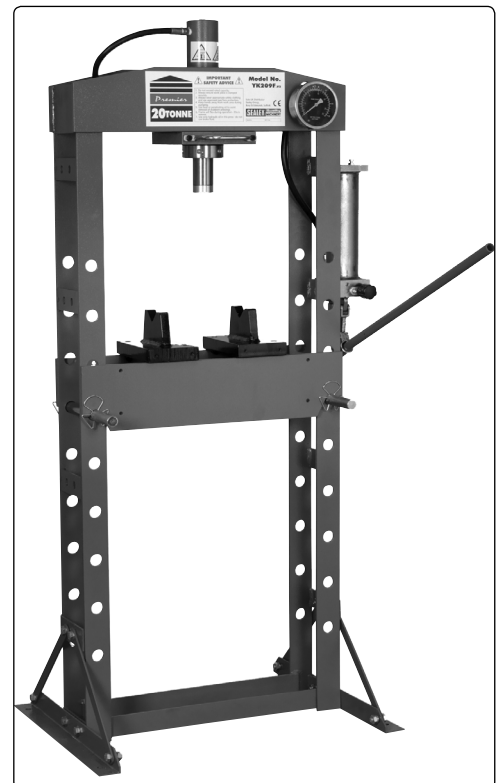

3. ASSEMBLY

3.1 YK209F.V2 20TONNE PRESS ASSEMBLY (use the exploded diagram Fig.4 as a guide to assembly as well as the diagrams below).

3.1.1. The bed frame is put in the bottom of the crate for transport, fix it to the uprights using bed frame pin (9) and circlip (10).

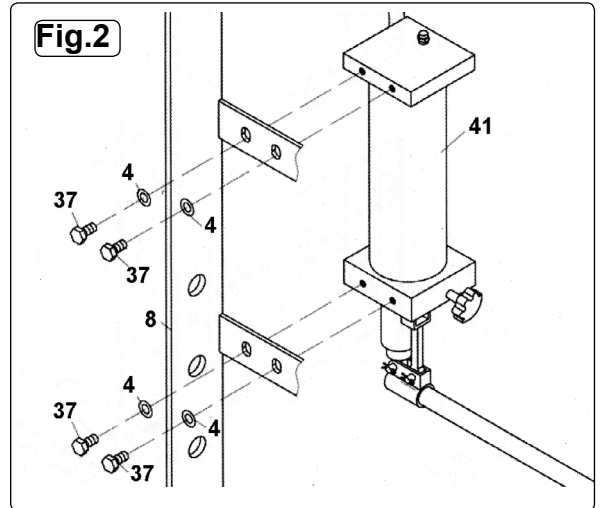
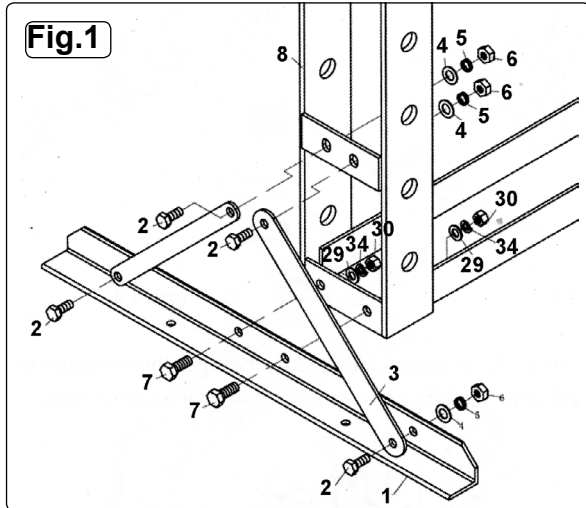

3.1.2. Attach the base section (1) and support pieces (3) to both the frame uprights, using bolt (2), washer (4), lock washer (5) and nut (6). Refer to fig.1.

3.1.3. Move the pump assembly to the outside of the post, secure using bolt (37) and washer (4), which held the pump to the inside of the post during transit. Refer to fig.2.

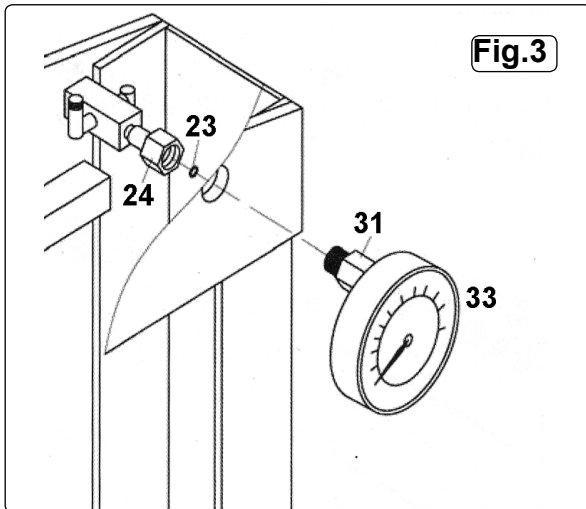

3.1.4. Assemble the gauge fitting (31) the nylon ring (32), (which fits between the gauge and the gauge fitting see fig.4), and the gauge (33). Twist the gauge as tight as possible to prevent it from leaking. Then the gauge and gauge fitting are fitted to the manifold (24).

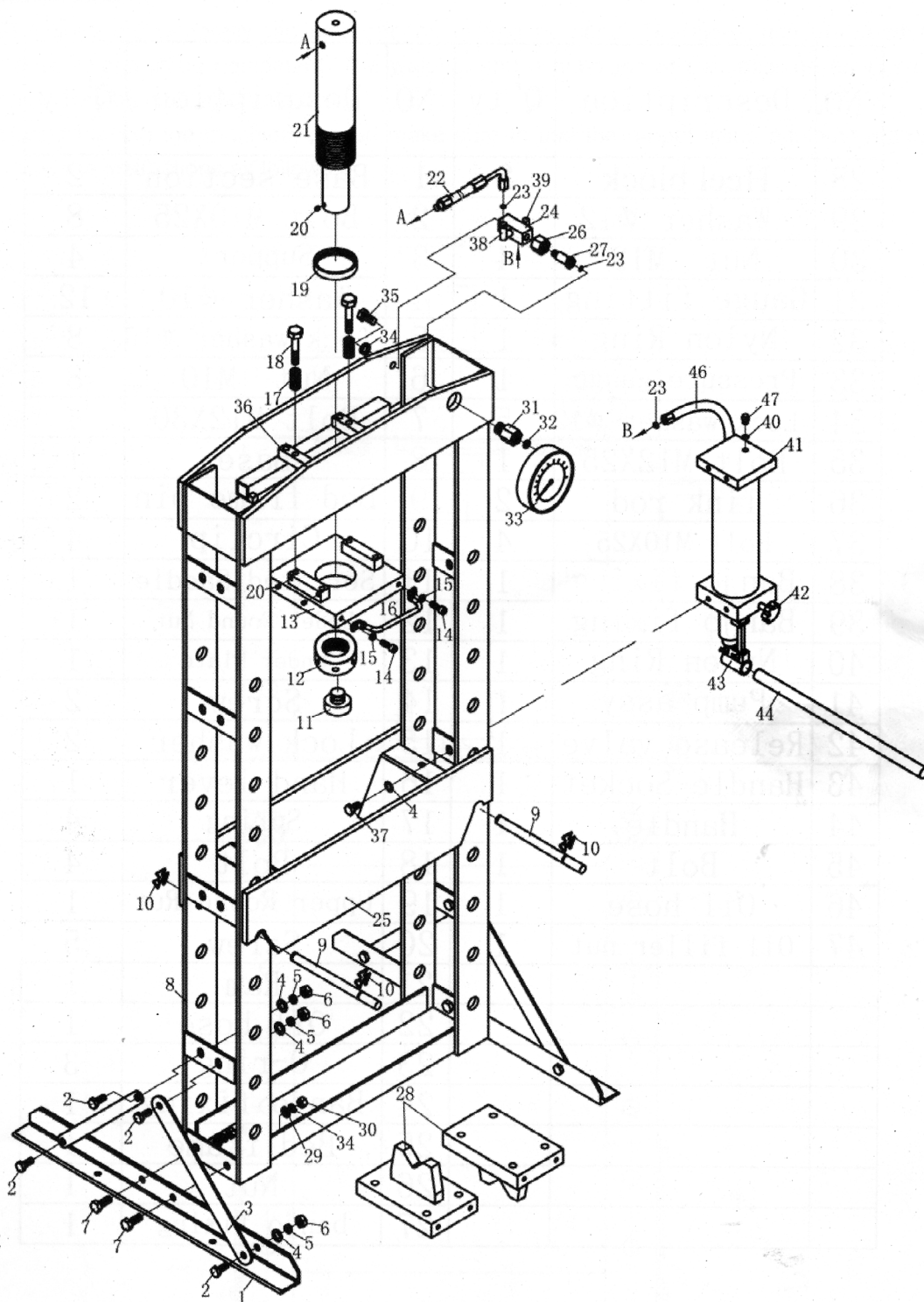

Fig.4

4. INSTALLATION & OPERATING

4.1. INSTALLATION.

4.1.1 Securely attach the press to a flat, firm, level surface taking into account clearance for working pieces.

▲ **DANGER! The press is top heavy.** If it requires moving after assembly or for relocation, use suitable slings around the top crossbeam, or lift direct with a forklift with the forks located under the top crossbeam. **DO NOT** use a pallet truck.

4.1.2 **Purge hydraulic system before operating the press.**

The hydraulic system may require purging in order to eliminate any air that may have built up during transit. Check the oil level and top up if required, open the release valve by turning anti-clockwise and pump the handle several times. Repeat if necessary.

▲ **DANGER! Press is purpose designed to withstand greater loads than the hydraulic units can develop. For safety reasons, always ensure the workpiece is secured on the table to ensure loads that flex will not suddenly "give" causing danger to operator or damage to component. Ensure you have read and understood chapter 1 safety instructions.**

4.2. OPERATING INSTRUCTIONS.

4.2.1 Check that the release valve on the hydraulic unit is fully closed, ready for operation.

4.2.2 Locate the flat pressing plates or the v-blocks on to the bed frame, push down the locating pins to ensure the plates do not slip. Place workpiece onto the plates and position the head of the hydraulic unit on the centre of the workpiece using an appropriate extension.

Note: Care must be taken to ensure the plates do not fall from the bed frame.

☐ **WARNING! DO NOT** apply off centre loads.

4.2.3 When work is complete turn the release valve anti-clockwise to release the pressure and the piston and the ram head will retract automatically. **Note:** Always keep the piston retracted after use.

5. MAINTENANCE

Note: Maintenance and repair must only be carried out by a qualified person. Contact your Sealey dealer for details.

5.1. Always keep the press clean, dry and lubricate all moving parts at regular intervals.

5.2. When not in use always store in a dry location with the piston retracted.

5.3. Should you need to check or replace oil ensure piston is fully retracted. Remove the oil reservoir filler plug (47) and top up using Sealey hydraulic jack oil. **DO NOT** use brake fluid. Contact your local Sealey dealer for details. After filling purge the system to remove any air.

IMPORTANT: NO RESPONSIBILITY IS ACCEPTED FOR INCORRECT USE OF THE PRESS.

Hydraulic products are only repaired by local service agents. We have service/repair agents in all parts of the UK.

DO NOT RETURN PRODUCT TO SEALEY. Please telephone Sealey on 01284 757500 to obtain the address and phone number of your local agent.

If product is under guarantee please contact your dealer.

De-commissioning Product

Should the product become completely unserviceable and require disposal, draw off the oil into an approved container and dispose of the product and the oil according to local regulations.

Parts support is available for this product. To obtain a listing and/or diagram, please log on to: www.sealey.co.uk, email: sales@sealey.co.uk or phone: 01284 757500



Environmental Protection.

Recycle unwanted materials instead of disposing of them as waste. All tools, accessories and packaging should be sorted, taken to a recycle centre and disposed of in a manner which is compatible with the environment.

IMPORTANT: NO RESPONSIBILITY IS ACCEPTED FOR INCORRECT USE OF THE MACHINE.

Hydraulic products are only repaired by local service agents. We have service/repair agents in all parts of the UK.

DO NOT RETURN PRODUCT TO US. Please telephone us on 01284 757500 to obtain the address and phone number of your local agent.

If product is under guarantee please contact your dealer.

De-commissioning Product

Should the product become completely unserviceable and require disposal, draw off the oil into an approved container and dispose of the product and the oil according to local regulations.

NOTE: It is our policy to continually improve products and as such we reserve the right to alter data, specifications and component parts without prior notice.

IMPORTANT: No liability is accepted for incorrect use of this product.

WARRANTY: Guarantee is 12 months from purchase date, proof of which will be required for any claim.

INFORMATION: For a copy of our latest catalogue and promotions call us on 01284 757525 and leave your full name and address, including postcode.



Sole UK Distributor, Sealey Group,
Kempson Way, Suffolk Business Park,
Bury St. Edmunds, Suffolk,
IP32 7AR



01284 757500



www.sealey.co.uk



01284 703534



sales@sealey.co.uk