



INSTRUCTIONS FOR:

# SUBMERSIBLE POND PUMP

MODEL No: **WPP1100**

Thank you for purchasing a Sealey product. Manufactured to a high standard, this product will, if used according to these instructions, and properly maintained, give you years of trouble free performance.



**IMPORTANT: PLEASE READ THESE INSTRUCTIONS CAREFULLY. NOTE THE SAFE OPERATIONAL REQUIREMENTS, WARNINGS & CAUTIONS. USE THE PRODUCT CORRECTLY AND WITH CARE FOR THE PURPOSE FOR WHICH IT IS INTENDED. FAILURE TO DO SO MAY CAUSE DAMAGE AND/OR PERSONAL INJURY AND WILL INVALIDATE THE WARRANTY. KEEP THESE INSTRUCTIONS SAFE FOR FUTURE USE.**

## 1. SAFETY

### 1.1. ELECTRICAL SAFETY

**WARNING!** It is the owner's responsibility to read, understand and comply with the following:

You must check all electrical equipment and appliances to ensure they are safe before using. You must inspect power supply leads, plugs and all electrical connections for wear and damage. You must ensure the risk of electric shock is minimised by the installation of appropriate safety devices. An RCCB (Residual Current Circuit Breaker) should be incorporated in the main distribution board. We also recommend that an RCD (Residual Current Device) is used with all electrical products. It is particularly important to use an RCD together with portable products that are plugged into an electrical supply not protected by an RCCB. If in doubt consult a qualified electrician. You may obtain a Residual Current Device by contacting your Sealey dealer. **You must** also read and understand the following instructions concerning electrical safety.

- 1.1.1. The Electricity At Work Act 1989 requires all portable electrical appliances, if used on business premises, to be tested by a qualified electrician, using a Portable Appliance Tester (PAT), at least once a year.
- 1.1.2. The **Health & Safety at Work Act 1974** makes owners of electrical appliances responsible for the safe condition of the appliance and the safety of the appliance operator. **If in any doubt about electrical safety, contact a qualified electrician.**
- 1.1.3. Ensure the insulation on all cables and the product itself is safe before connecting to the mains power supply. The pump and cable are designed for submerging in water and as such must not be tampered with (if in doubt, contact a qualified electrician).
- 1.1.4. Ensure that cables are always protected against short circuit and overload.
- 1.1.5. Regularly inspect power supply leads, plugs and all electrical connections for wear and damage, especially power connections, to ensure that none is loose.
- 1.1.6. **Important:** Ensure the voltage marked on the product is the same as the electrical power supply to be used, and check that plugs are fitted with the correct capacity fuse. A 13 amp plug may require a fuse smaller than 13 amps for certain products, see fuse rating at right.
- 1.1.7. **DO NOT** pull or carry the appliance by its power supply lead.
- 1.1.8. **DO NOT** pull power plugs from sockets by the power cable.
- 1.1.9. **DO NOT** use worn or damaged leads, plugs or connections. Immediately replace or have repaired by a qualified electrician.

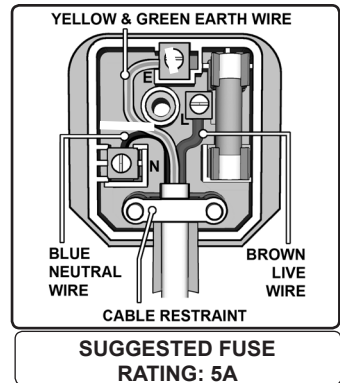

A U.K. 3 pin plug with ASTA/BS approval is fitted. In case of damage, cut off and fit a new plug according to the following instructions (discard old plug safely).

(UK only - see diagram at right). **Ensure the unit is correctly earthed via a three-pin plug.**

- a) **Connect the GREEN/YELLOW earth wire to the earth terminal 'E'.**
- b) **Connect the BROWN live wire to live terminal 'L'.**
- c) **Connect the BLUE neutral wire to the neutral terminal 'N'.**
- d) **After wiring, check that there are no bare wires, that all wires have been correctly connected, that the cable outer insulation extends beyond the cable restraint and that the restraint is tight.**

- 1.1.10. The electrical cable is designed for use in water and must not be substituted. If damaged contact a qualified electrician.
- 1.1.11. **Extension cable use. Only use a cable designed for use with water equipment. Contact your dealer or a qualified electrician for advice. Ensure water is kept clear of electrical mains power supply. DO NOT touch switch or plug with wet hands.**

### 1.2. GENERAL SAFETY

- WARNING!** This pump must be used in accordance with Health & Safety, government, local authority and water authority rules and regulations including appropriate procedures for the protection of persons, animals, equipment and property.
  - ✓ Familiarise yourself with application, limitations and potential hazards peculiar to the pump.
  - WARNING!** Disconnect the pump from the mains power before changing accessories, servicing or performing any maintenance.
  - WARNING! DO NOT** have contact with the water whilst the submerged pump is connected to the mains supply.
  - ✓ Maintain the pump in good condition (use an authorised service agent). Keep the pump clean.
  - ✓ Replace or repair damaged parts. *Use genuine parts only. Unauthorised parts may be dangerous and will invalidate the warranty.*
  - ✓ Switch off the power on all devices that are in contact with the water before carrying out any cleaning or maintenance work on the device.
  - DO NOT** use the pump for any purpose other than for which it is designed.
  - DO NOT** operate the pump out of water. The pump pick-up area must be completely submerged during operation.
  - DO NOT** operate the pump during freezing temperatures. **DO NOT** leave the pump in water that may freeze.
  - DO NOT** carry the pump by its electrical cable, or outlet pipe.
  - DO NOT** use the device in water additionally chlorinated or in acidic or alkaline solutions.
  - DO NOT** use in salt water.
  - DO NOT** let the pump run dry. This can cause irreparable damage.
- This appliance can be used by children aged from 8 years and above and persons with reduced physical, sensory or mental capabilities or lack of experience and knowledge if they have been given supervision or instruction concerning use of the appliance in a safe way and understand the hazards involved. Children shall not play with the appliance. Cleaning and user maintenance shall not be made by children without supervision

## 2. INTRODUCTION & SPECIFICATION

A pond pump suitable for creating garden water fountain features. It also provides the important functions of filtration and water circulation which are necessary to maintain healthy plant and fish life. WPP1100 comes with two fountain heads Cascade and Water Bell. The pumps compact design makes it very powerful yet at the same time energy efficient. A magnetic impeller is driven by a leak proof synchronous motor.

### Technical Data.

Model No:	<b>WPP1100</b>
Power Consumption:	230V 20W
Max. Head:	1.1mtr
Max. Flow Rate:	1100ltr/hr
Max. Submersion Depth:	3mtr
Power Cable:	10mtr
Max. Temp. of the Pumped Fluid:	35°C
Protection Type:	IP68

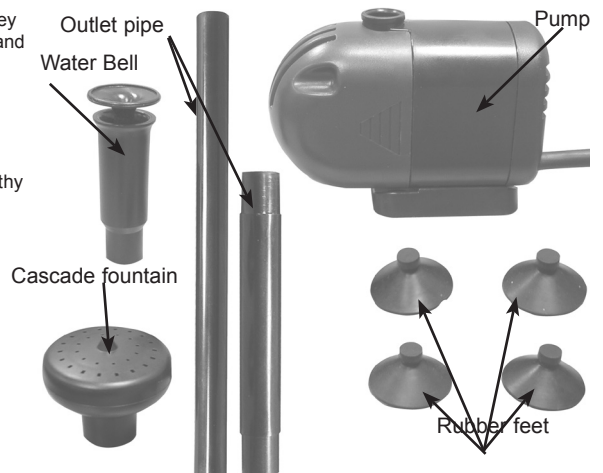

### 3. OPERATION

- ❑ **WARNING!** Ensure that you read, understand and apply the safety instructions in Section 1.

#### 3.1. Start-up.

- 3.1.1. Fit the four rubber feet to the base of the pump.
- 3.1.2. Place the pump on a flat level surface which is raised from the bottom of the pond. This will prevent the pump from clogging too quickly.
- 3.1.3. You may use the pump lying on its side. You should however, make sure that the motor axle is horizontal, otherwise the axle will be subject to increased wear.

#### 3.2. Cascade Fountain Mode.

- 3.2.1. When installing the pump in the pond, make sure that the cascade fountain head projects above the water surface.  
Refer to Fig 1 for the maximum delivery height and diameter.

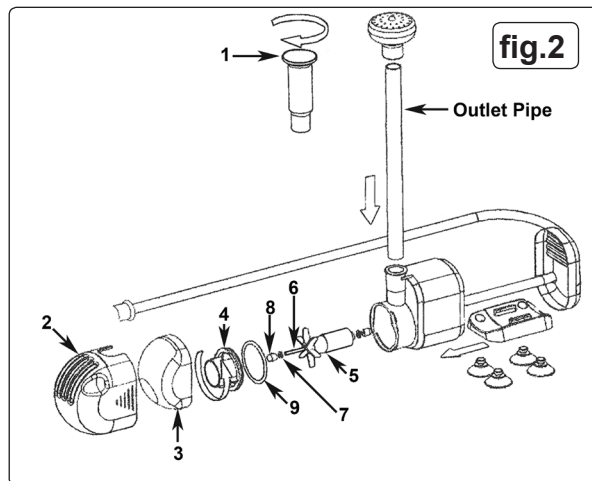
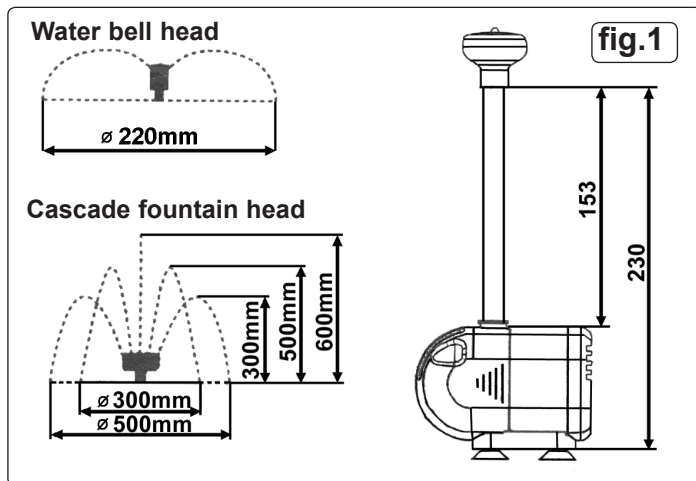

#### 3.3. Water Bell Fountain Mode.

- 3.3.1. Install the water bell fountain head onto the outlet pipe.
- 3.3.2. The closer the head is to the water surface, the larger the diameter of the water bell that can be achieved.
- 3.3.3. You can adjust the volume of water and the size of the bell by screwing the top of the water bell head in or out. Fig 2.1.

### 4. MAINTENANCE

- ❑ **WARNING!** With the exceptions listed below, all pump and electrical cable service maintenance and repair must be undertaken by an authorised service agent only. Failure to observe this rule may be dangerous and will invalidate your warranty.

- ❑ **WARNING!** Ensure that the pump is disconnected from the mains power supply before attempting any service or maintenance.  
NOTE: The pump's filter should only be cleaned out when necessary, as cleaning will simultaneously wash out the micro organisms which help to keep the pond healthy. However, it should be cleaned whenever there is a noticeable deterioration in pump performance.

#### 4.1. Cleaning the filter sponge.

- 4.1.1. Press the filter housing together on both sides (fig 2.2) and pull off the cover.
- 4.1.2. Remove the sponge filter (fig 2.3) from the housing and clean with clean cold water.  
**CAUTION:** Never use the pump without the filter in place as this could lead to damage to the pump.

#### 4.2. Cleaning the functioning parts.

- 4.2.1. Open the pump chamber lid (fig 2.4) by twisting it anti-clockwise a quarter turn and pulling it clear of the pump body.
- 4.2.2. Remove the magnetic impeller (fig 2.5) carefully from the shaft. As this is done the magnetic force of the impeller must be overcome.
- 4.2.3. **Do not** use any implements to remove dirt from inside the pump, but simply wash it out with lukewarm water.
- 4.2.4. Use a soft sponge to remove any dirt deposits.
- 4.2.5. To reassemble the pump carefully slide the magnetic impeller onto the shaft. At a certain point, the impeller will be drawn into the housing by the magnetic force.
- 4.2.6. Check that the ceramic washer (fig 2.7) and rubber bearing (fig 2.8) at both ends of the shaft are correctly mounted.
- 4.2.7. Before closing the pump chamber with the lid (fig 2.4) make sure that the o-ring (fig 2.9) is correctly seated.
- 4.2.8. Plug the supply cable into the mains supply briefly (no more than 3 seconds) to check that the impeller turns freely. A certain level of noise is inevitable during this dry run. This is no cause for concern. When it is used in water, the pump should operate silently.

#### 4.3. Winter storage

- 4.3.1. Place the pump in water filled vessel in a frost-free room. Storage in water prevents deposits from accumulating on the pump. If the pump is stored dry, these deposits can block the impeller. If you wish to store the pump dry, you must ensure that the functioning parts and filters have been thoroughly cleaned and dried.

#### Environmental Protection

Recycle unwanted materials instead of disposing of them as waste. All tools, accessories and packaging should be sorted, taken to a recycling centre and disposed of in a manner which is compatible with the environment.  
When the product becomes completely unserviceable and requires disposal, drain off any fluids (if applicable) into approved containers and dispose of the product and the fluids according to local regulations.

#### WEEE Regulations

Dispose of this product at the end of its working life in compliance with the EU Directive on Waste Electrical and Electronic Equipment (WEEE). When the product is no longer required, it must be disposed of in an environmentally protective way. Contact your local solid waste authority for recycling information.

**NOTE:** It is our policy to continually improve products and as such we reserve the right to alter data, specifications and component parts without prior notice.

**IMPORTANT:** No liability is accepted for incorrect use of this product.

**WARRANTY:** Guarantee is 12 months from purchase date, proof of which will be required for any claim.

**INFORMATION:** For a copy of our latest catalogue and promotions call us on 01284 757525 and leave your full name and address, including postcode.



**Sole UK Distributor, Sealey Group,**  
Kempson Way, Suffolk Business Park,  
Bury St. Edmunds, Suffolk,  
IP32 7AR

01284 757500

www.sealey.co.uk

01284 703534

sales@sealey.co.uk