

Thank you for purchasing a Sealey product. Manufactured to a high standard this product will, if used according to these instructions and properly maintained, give you years of trouble free performance.



**IMPORTANT: PLEASE READ THESE INSTRUCTIONS CAREFULLY. NOTE THE SAFE OPERATIONAL REQUIREMENTS, WARNINGS AND CAUTIONS. USE THE PRODUCT CORRECTLY AND WITH CARE FOR THE PURPOSE FOR WHICH IT IS INTENDED. FAILURE TO DO SO MAY CAUSE DAMAGE AND/OR PERSONAL INJURY AND WILL INVALIDATE THE WARRANTY. PLEASE KEEP INSTRUCTIONS SAFE FOR FUTURE USE.**

**TECHNICAL HELP LINE NO. 01284 757505**

Please register your product with Sealey by completing the registration form on-line at [www.sealey.co.uk](http://www.sealey.co.uk)  
Navigate to Register Product. By registering your product you can take advantage of Sealey product and technical updates via email.

**1. SAFETY INSTRUCTIONS**

- WARNING!** Ensure that Health and Safety, local authority and general Workshop practice regulations are strictly adhered to.
- DO NOT** use the unit if it, or any attachment, is damaged.
- If required, ensure that the vehicle to be worked on is adequately supported with axle stands or ramps and is chocked.
- Put transmission in PARK (for automatic transmission) or NEUTRAL (for manual transmission) and make sure the parking brake is engaged.
- Wear approved eye protection. A full range of personal safety equipment is available from your Sealey dealer.
- Wear suitable clothing to avoid snagging. Do not wear jewellery and tie back long hair.
- WARNING!** Use extreme caution when working around the ignition coil, distributor cap, ignition wires and spark plugs. These components create hazardous voltages when the engine is running.
- DO NOT** connect or disconnect any test equipment with ignition on or engine running.
- Keep a fire extinguisher suitable for gasoline/chemical/electrical fires nearby.
- Account for all tools and parts being used and do not leave them on or near the engine.
- Keep reset tool dry, clean and free from oil, water and grease. Use a mild detergent on a clean cloth to clean the outside of the tool.
- Operate the vehicle in a well-ventilated work area; exhaust gases are poisonous.  
**IMPORTANT:** Always refer to the vehicle manufacturer's service instructions to establish the current procedure and data. These instructions are provided as a guide only.
- WARNING! The warnings and instructions discussed in this manual cannot cover all possible conditions and situations that may occur. It must be understood that common sense and caution are factors which cannot be built into this product, but must be applied by the operator.**

**2. INTRODUCTION**

Alfa Romeo, Fiat and Lancia oil service and oil degradation reset tool. Compatible with the latest Fault Tolerant CAN vehicles. Designed to extinguish the oil service light and to show if there is a fault on the CAN bus which is a common problem with some vehicles.

**NOTE:** It is our policy to continually improve products and as such we reserve the right to alter data, specifications and component parts without prior notice.

**IMPORTANT:** No liability is accepted for incorrect use of this product.

**WARRANTY:** Guarantee is 12 months from purchase date, proof of which will be required for any claim.

**INFORMATION:** For a copy of our latest catalogue and promotions call us on 01284 757525 and leave your full name and address, including postcode.



### 3. FEATURES / OPERATION

- Compatible with latest Fault Tolerant CAN vehicles.
- Also compatible with Alfa Romeo Mito, Fiat Punto 05 , Grand Punto & 500.
- CAN BUS Fault indicator.

The new FIAT service reset tool has been designed to extinguish service lights for the latest FIAT Fault Tolerant CAN vehicles.

In addition to service reset, the tool has been designed to display a warning lamp when a fault on the CAN bus is present, thus serving as a useful diagnostic aid for all vehicle systems.

**Service Reset Type 1** – Will reset the service dependent on the service schedule for vehicles labelled Type 1.

**Service Reset Type 2** – Will reset the service dependent on the service schedule for vehicles labelled Type 2.

**Oil Light Reset** – Resets the Oil Degradation indicator. Only on models with Diesel Particulate Filter (DPF).

The 'CAN FAULT' LED will flash on initial power up of the SLR tool if a CAN Bus fault is present.

●	○	○	Service Reset Type 1
○	●	○	Service Reset Type 2
○	○	●	Oil Degradation Reset (DPF only)

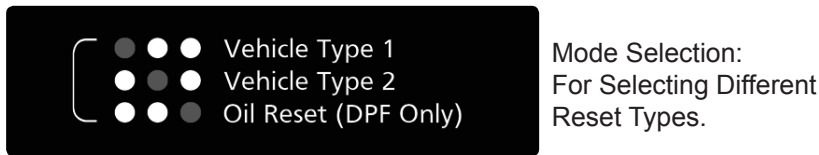

#### Vehicle Set-Up.

1. Connect to vehicle.
2. Switch ignition on.





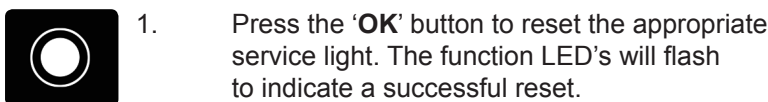

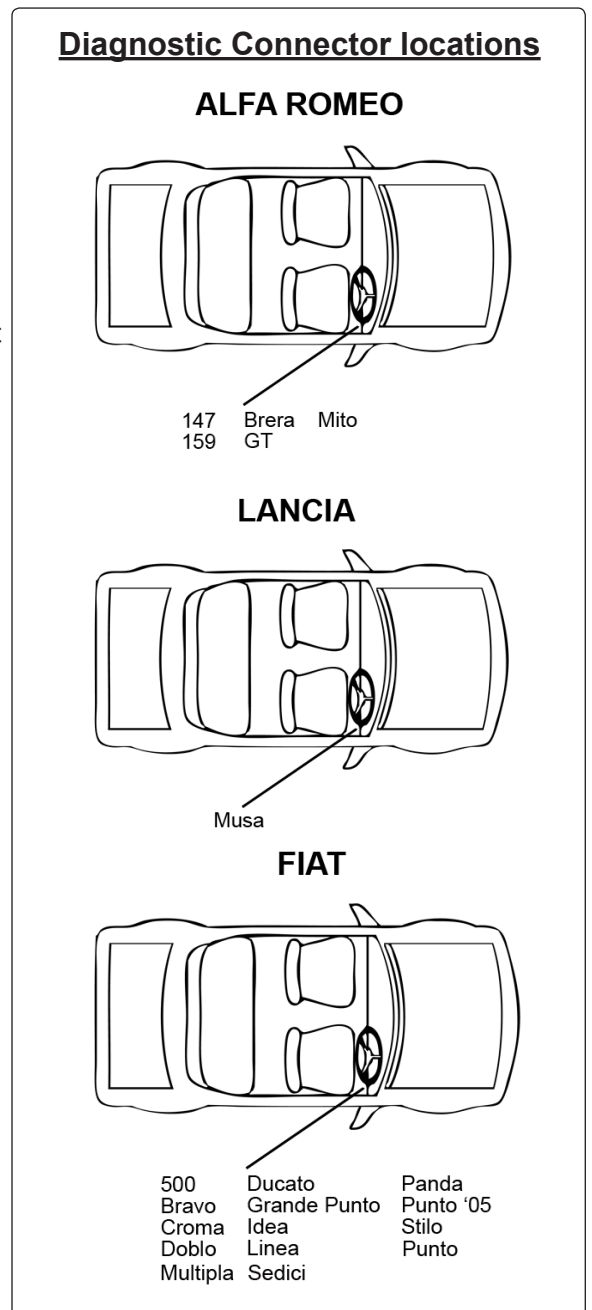
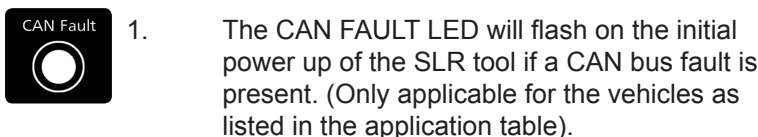

3. Press mode button to select correct reset type.
4. Press the 'OK' button to perform reset.



#### CAN bus Fault



## 4. APPLICATIONS

						Type
<b>Service Reset</b>						
<b>Alfa Romeo</b>						
147	All Variants	P/D	All	05-07		Type 1
159	All Variants	P/D	All	05-09		Type 1
BRERA	All Variants	P/D	All	05-07		Type 1
GT	All Variants	P/D	All	05-07		Type 1
MiTo	All Variants	P/D	All	08-09		Type 2
<b>Fiat</b>						
500	All Variants	P/D	All	07-09		Type 2
BRAVO	All Variants	P/D	All			Type 1
CROMA	All Variants	P/D	All	05-08		Type 1
DOBLO	All Variants	P/D	All	01-06		Type 1
DUCATO	All Variants	P/D	All	06-08		Type 1
GRANDE PUNTO	All Variants	P/D	All	05-09		Type 2
IDEA	All Variants	P/D	All	04-06		Type 1
LINEA	All Variants	P/D	All	05-07		Type 1
PANDA	All Variants	P/D	All	03-07		Type 1
PUNTO	All Variants	P/D	All	03-05		Type 1
PUNTO '05	All Variants	P/D	All	05-09		Type 2
PUNTO LA	All Variants	P/D	All	03-07		Type 1
STILO	All Variants	P/D	All	01-07		Type 1
<b>Lancia</b>						
MUSA	All Variants	P/D	All	04-09		Type 1
<b>Oil Degradation</b>						
<b>Alfa Romeo</b>						
159	1.9 JTDm 115	D	1.9	05-07	939A7.000	Bosch EDC16C39
159	1.9 JTDm 120	D	1.9	05-07	939A1.000	Bosch EDC16C39
159	1.9 JTDm 16V 136	D	1.9	05-07	939A8.000	Bosch EDC16C39
159	1.9 JTDm 16V 150	D	1.9	05-07	939A2.000	Bosch EDC16C39
159	2.4 JTDm 20V	D	2.4	05-07	939A3.000	Bosch EDC16C39
BRERA	2.4 JTDm 20V	D	2.4	05-07	939A3.000	Bosch EDC16C39
<b>Fiat</b>						
BRAVO	1.9 JTD	D	1.9	07-09		Bosch EDC16C39
CROMA	1.9 JTD 8V	D	1.9	05-09	939A1.000	Bosch EDC16C39
GRANDE PUNTO	1.9 JTD 16V	D	1.9	05-07	199A5.000	Bosch EDC16C39
IDEA	1.9 JTD 8V	D	1.9	05-07	939A1.000	Bosch EDC16C39
MULTIPLA	1.9 JTD	D	1.9	02-09		Bosch EDC16C39
PUNTO	1.9 JTD 16V	D	1.9	05-09	192A5.000	Bosch EDC16C39
PUNTO	1.9 JTD 8V	D	1.9	05-09	939A1.000	Bosch EDC16C39
SEDICI	1.9 JTD 8V	D	1.9	05-09	939A1.000	Bosch EDC16C39
STILO	1.9 JTD 16V 140	D	1.9	04-09	192A5.000	Bosch EDC16C39

**NOTE:** It is our policy to continually improve products and as such we reserve the right to alter data, specifications and component parts without prior notice.

**IMPORTANT:** No liability is accepted for incorrect use of this product.

**WARRANTY:** Guarantee is 12 months from purchase date, proof of which will be required for any claim.

**INFORMATION:** For a copy of our latest catalogue and promotions call us on 01284 757525 and leave your full name and address, including postcode.



**Sole UK Distributor, Sealey Group,**  
Kempson Way, Suffolk Business Park,  
Bury St. Edmunds, Suffolk,  
IP32 7AR

 01284 757500

 01284 703534

 [www.sealey.co.uk](http://www.sealey.co.uk)

 [sales@sealey.co.uk](mailto:sales@sealey.co.uk)



**Environmental Protection.**

Recycle unwanted materials instead of disposing of them as waste. All tools, accessories and packaging should be sorted, taken to a recycle centre and disposed of in a manner which is compatible with the environment.

When the product is no longer required, it must be disposed of in an environmentally protective way.

**NOTE:** It is our policy to continually improve products and as such we reserve the right to alter data, specifications and component parts without prior notice.

**IMPORTANT:** No liability is accepted for incorrect use of this product.

**WARRANTY:** Guarantee is 12 months from purchase date, proof of which will be required for any claim.

**INFORMATION:** For a copy of our latest catalogue and promotions call us on 01284 757525 and leave your full name and address, including postcode.

