



IMPORTANT: PLEASE READ THESE INSTRUCTIONS CAREFULLY. NOTE THE SAFE OPERATIONAL REQUIREMENTS, WARNINGS AND CAUTIONS. ALSO CONSULT YOUR VEHICLE MANUFACTURER'S HANDBOOK AND TAKE NOTE OF ANY SPECIAL INSTRUCTIONS RELATING TO TOWING, PARTICULARLY FOR VEHICLES WITH AUTOMATIC TRANSMISSIONS. USE THIS PRODUCT CORRECTLY AND WITH CARE FOR THE PURPOSE FOR WHICH IT IS INTENDED. FAILURE TO DO SO MAY CAUSE DAMAGE OR PERSONAL INJURY AND WILL INVALIDATE THE WARRANTY. PLEASE KEEP INSTRUCTIONS SAFE FOR FUTURE USE.

1. SAFETY INSTRUCTIONS

- ✓ Maintain the tow pole in good condition. If the tow pole is damaged, remove from service.
- ✓ Check vehicle manufacturer's instructions to determine whether the vehicle is equipped with proper tow fittings suitable for use with a tow pole. Also any special instructions for vehicles with automatic transmission or four wheel drive.
- ✓ Use tow pole only on vehicles with standard tow eyes. **DO NOT** use transportation 'tie down' points.
- ✓ Ensure the tow eyes, and the areas of the vehicles to which the eyes are fitted, are strong and solid enough for towing. **DO NOT** use the tow pole if there is damage or heavy rust around the fitting area and ensure the eyes are approximately the same height from the ground.
- ✓ Place an "ON TOW" notice in the back window or other visible location at the rear of the towed vehicle. Attach a red marker (provided) to the centre of the tow pole.
- ✓ The vehicle to be towed must be fully legal in respect of having the registration number visible at all times, must have a valid road tax, insurance and relevant current DOT test certificate. **DO NOT** tow a vehicle that lacks one or more of these requirements.
- ✓ Towed vehicle must have the ignition on in order to operate lights, brake lights and indicators. If these lights cannot be operated, you must fit a repeater trailer board to towed vehicle. Contact your local Sealey dealer for information relating to approved towing boards which must incorporate lighting and signalling equipment.
- ✓ Ensure that the person in the towed vehicle is aware that, if servo brakes and/or power steering are fitted, then braking and/or steering efforts will be very much higher than normal when the engine is not running.
- 3 Read vehicle manufacturers instructions before use.
- x **DO NOT** exceed the rated capacity of the tow pole.
- x **DO NOT** exceed a maximum towing speed of 15mph.
- x **DO NOT** use the tow pole if damaged.
- x **DO NOT** tow vehicle if the steering lock cannot be disengaged.
- x **DO NOT** use the tow pole on a vehicle with defective braking system.
- x **DO NOT** tow an unmanned vehicle.
- x **DO NOT** force the tow pole to achieve a task it was not designed to perform.
- x **DO NOT** allow untrained persons to use the tow pole.
- x **DO NOT** operate the tow pole if any parts are missing as this may cause failure and possible personal injury.

2. DESCRIPTION & ASSEMBLY

2.5tonne Rolling load capacity rigid tow pole. Hook mechanism allows for mounting pole between vehicles where towing eyes may be mixed, i.e. not both horizontal or vertical.

2.1. Specification

Tow pole length.....	1.8m.
Rolling load capacity.....	2500kg.

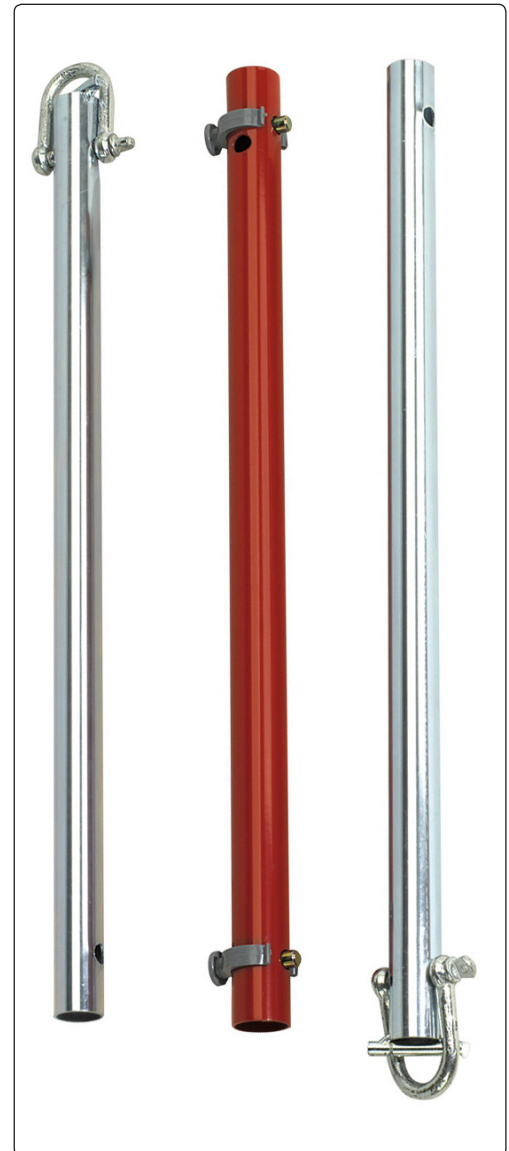

3. TOWING INFORMATION

IMPORTANT INFORMATION REGARDING THE TOWING OF VEHICLES WITH AUTOMATIC TRANSMISSION AND FOUR WHEEL DRIVE VEHICLES.

- 3.1 **Before towing a four wheel drive vehicle or a vehicle with automatic transmission it is essential to consult the manufacturer's handbook for the vehicle to be towed to check the correct towing procedure.** The correct procedure will vary from vehicle to vehicle depending on the configuration of the transmission. (In some cases certain 4WD vehicles cannot be towed with all four wheels on the ground and will have to be transported on a trailer). Failure to observe the correct procedure could result in severe damage to the vehicles transmission.
- 3.2 Many automatic transmissions require the engine to be active in order to drive a pump that provides lubrication to the transmission. If the transmission is turned by the road wheels without the engine running, permanent damage could be done to the transmission due to lack of lubrication. This could also apply to the secondary gearbox on a four wheel drive vehicle.
- 3.3 Four wheel drive systems are designed to run in tandem with the engine. If the engine is off but the transmission is driven at speed by the road wheels the mismatch in speed between components within the gearboxes could also result in permanent damage to the transmission.
- 3.4 It is usually possible to tow four wheel drive vehicles with manual transmission as the engine can be disconnected from the primary gearbox. However, the road wheels may still be driving a secondary gearbox. The manufacturer will state in which drive position the secondary gearbox should be placed. and will recommend a maximum towing speed. A towing distance and/or time limit may also be imposed by the manufacturer.
- 3.5 Some four wheel vehicles are fitted with devices to disconnect the hubs and/ or driveshafts especially for towing purposes.
- 3.6 Consult the manufacturer's handbook before reversing with a four wheel drive vehicle attached or a vehicle with automatic transmission.
- 3.7 **REMEMBER, ALWAYS FOLLOW THE VEHICLE MANUFACTURERS RECOMMENDATIONS FOR THE VEHICLE TO BE TOWED.**

4. ASSEMBLY

4.1. Assembly

Remove contents from packing and check to ensure everything is correct and undamaged. Should you experience any problems contact your supplier immediately.

- 4.1.1. Position the towing vehicle so that the distance between the towing eyes is approximately 1.8 metres.
- 4.1.2. Insert shackle (A) through the towing eye on the towing vehicle. Introduce tube (B) into the shackle, align the holes in the two components and screw the shackle bolt (C) fully into position.
- 4.1.3. Slide the central tube (D) over the end of tube (B) and align the holes in the two components. Insert the sprung pin (E) to hold the two tubes together.
- 4.1.4. Insert tube (F) into the other end of the central tube (D). Align the holes in the two components and insert the other sprung pin (G).
- 4.1.5. If the towing eyes on the two vehicles are not in the same plane, turn tube (F) through 90° and insert the sprung pin through the alternative holes on axis (XX).
- 4.1.6. Insert shackle (H) through the towing eye on the vehicle to be towed and if necessary carefully adjust the distance between the two vehicles so that shackle bolt (J) can be inserted and screwed fully down.

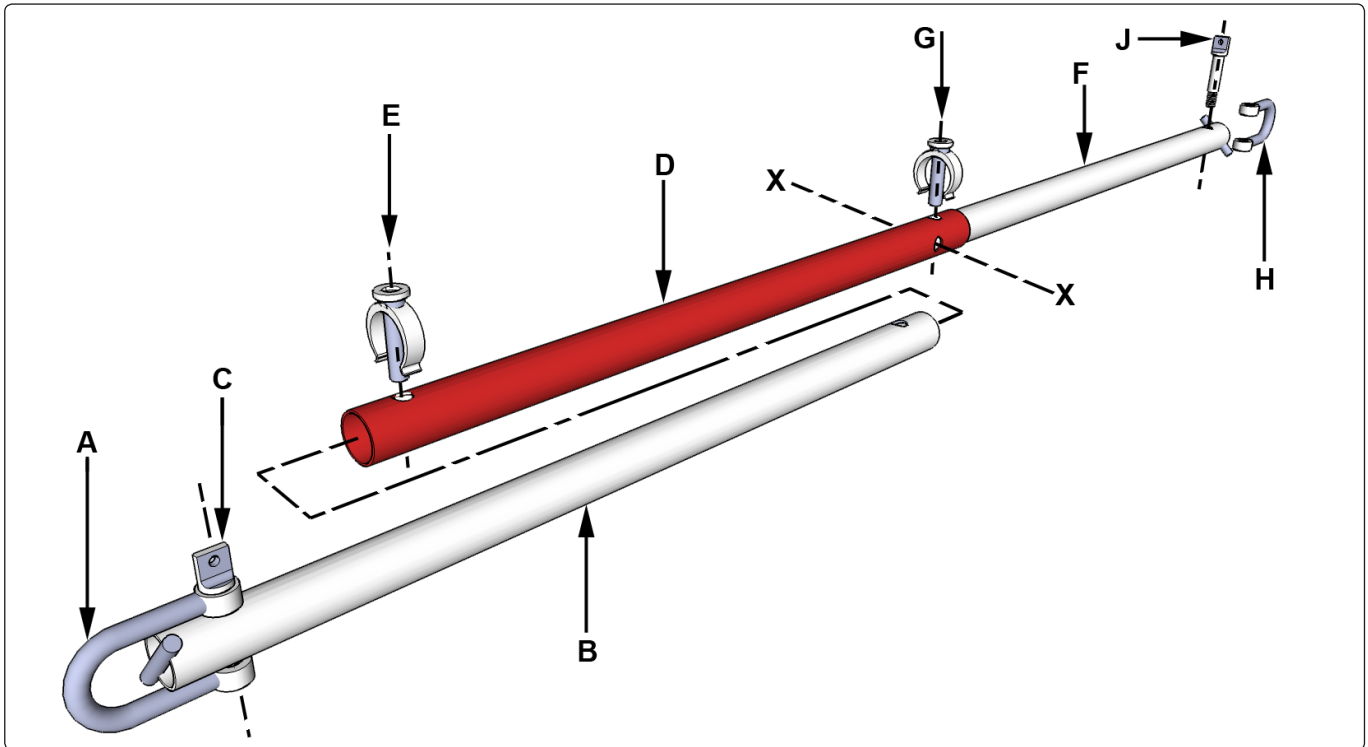

5. TOWING PROCEDURE

TPK253 has a rolling load capacity of 2.5 tonne, based on a level surface. Remember the weight of towed vehicle should be calculated to include any load in the vehicle, and to take into account any extreme gradients.

- **WARNING! Before using equipment ensure you have read, understood and apply Section 1 safety instructions.**
- TOWING EYES** - Many vehicle manufacturers include a separate towing eye which is not permanently fixed to the chassis. **Important: Before fitting the tow pole, to either vehicle, check the manufacturers' handbooks to ensure that the towing points (do not use 'tie points') are suitable for use with a tow pole and are capable of safely withstanding a 'brake load'.**
- LEGAL REQUIREMENTS** - It is the responsibility of the towing driver to ensure that all legal requirements are met. This includes the towing operation and actions taken by the towed driver. Check you are insured for towing. Trade users must have a "Trade Insurance Policy" which covers commercial towing. Note the policy will not provide cover if the law is broken, or the weight of towed load exceeds the capacity of the tow pole, or if towed vehicle weighs more than the towing vehicle. When calculating the weight of the towed vehicle remember that any load carried in the vehicle must be added to the kerb weight indicated in the manufacturer's handbook.
- 5.8. When towing, unlock the steering wheel and activate the warning lights on both vehicles. Ensure that the towed vehicle is in neutral, the wheels are free to rotate, and that hand and foot brakes are disengaged.
 - 5.9. While driving, the tow pole must remain parallel with the direction of travel, i.e. if the tow fittings are placed on different sides of the vehicles, it will be necessary to drive out of line (the car being towed would not be directly behind the one towing). Pole must also be approximately parallel with the road surface i.e. with the towing eyes at similar heights.
 - 5.10. The distance between the vehicles must be enough for the driver in the towed vehicle to see the rear lights of the towing vehicle.
 - 5.11. **A MAXIMUM SPEED OF 15MPH** should not be exceeded.
 - 5.12. Always take great care when towing and ensure a very gradual "take-up" when starting and braking. **WARNING!** The tow pole and fittings are not able to withstand shock loads resulting from sudden changes in speed.
 - 5.13. After use, dismantle the tow pole, clean it and store it in a dry place. Inspect regularly for signs of stress or wear. Replacement parts are not available for this unit.

NOTE: It is our policy to continually improve products and as such we reserve the right to alter data, specifications and component parts without prior notice.

IMPORTANT: No liability is accepted for incorrect use of this product.

WARRANTY: Guarantee is 12 months from purchase date, proof of which will be required for any claim.

INFORMATION: For a copy of our latest catalogue and promotions call us on 01284 757525 and leave your full name and address, including postcode.



Sole UK Distributor, Sealey Group,
Kempson Way, Suffolk Business Park,
Bury St. Edmunds, Suffolk,
IP32 7AR

01284 757500
01284 703534

www.sealey.co.uk
sales@sealey.co.uk