



INSTRUCTIONS FOR: TRANSMISSION
 JACK YANKEE 1 TONNE/1.5 TONNE FLOOR
 Model No's: **TJ1000F, TJ1500F**

Thank you for purchasing a Sealey product. Manufactured to a high standard this product will, if used according to these instructions and properly maintained, give you years of trouble free performance.



IMPORTANT! ENSURE YOU READ AND UNDERSTAND THESE INSTRUCTIONS FULLY BEFORE ATTEMPTING TO USE THE JACK. NOTE THE SAFE OPERATIONAL REQUIREMENTS, DANGERS, WARNINGS & CAUTIONS. USE THE JACK CORRECTLY AND WITH CARE FOR THE PURPOSE FOR WHICH IT IS INTENDED. **WARNING!** FAILURE TO APPLY THESE INSTRUCTIONS MAY CAUSE *DAMAGE, SERIOUS PERSONAL OR FATAL INJURY*. FAILING TO FOLLOW INSTRUCTIONS WILL ALSO INVALIDATE YOUR WARRANTY. KEEP THESE INSTRUCTIONS SAFE FOR FUTURE USE.

NOTE: The use of symbols in this document is to attract your attention to possible danger. The symbols and warnings themselves do not eliminate any danger, nor are they substitutes for proper accident prevention measures.

1. SAFETY INSTRUCTIONS

- WARNING!** Ensure all preliminary checks are carefully carried out before use of jack. Immediately repair or replace damaged parts (use authorised service agent). Ensure use of *genuine parts only*. *Non authorised parts may be dangerous and will invalidate the warranty.*
- WARNING!** Use jack on level and solid ground, preferably concrete. Ensure the floor over which the jack will be transported is swept clean.
- DANGER!** DO NOT use on tarmac, or any other soft surface as jack may sink or topple. *Serious personal or fatal injury may result.*
- Use jack in an adequate working area for its function, keep area clean, tidy and free from unrelated materials. Ensure there is adequate lighting.
- Before use ensure the gearbox weight and size does not exceed the capacity of the jack.
- Ensure the vehicle is raised and stabilised at the correct height before attempting to move the jack under the vehicle.
- Keep all unauthorised persons away from the jack during lifting and lowering and when in transit.
- Maintain correct balance and footing. Ensure the floor is not slippery and wear non-slip shoes.
- Remove ill fitting clothing, ties, watches, rings, and other loose jewellery, contain or tie back long hair.
- WARNING!** Ensure load is placed level and centrally on jack saddle and load is fixed in place before attempting to lift, lower, or transport.
- The lowering speed will vary according to the weight of the load and the release valve setting.
- Ensure the jack saddle is fully lowered and is clean, dry, and oil free before attempting to transport the jack with or without a load.
- Fix load with support chain provided, do not substitute an inferior form of restraint for the support chain.
- Diligence is required in ensuring that you continually monitor the operation until completed.
- Should the jack omit any abnormal sounds during use STOP immediately and contact your local service agent.
- DANGER!** If jack tips or leans STOP WHAT YOU ARE DOING. MOVE QUICKLY TO A SAFE DISTANCE. DO NOT TRY TO HOLD OR STEADY JACK. *Serious personal or fatal injury may result.*
- WARNING!** DO NOT operate jack if any parts are damaged or missing .
- DO NOT exceed the rated capacity of the jack.
- DO NOT allow untrained persons to operate the jack.
- DO NOT place any part of your body within or under the jack during use.
- DO NOT raise or lower vehicle lifting platform whilst the transmission jack is being used.
- DO NOT transport the jack, with or without a load, with the saddle in the raised position.
- DO NOT get jack wet or use in damp or wet locations or areas where there is condensation.
- DO NOT operate the jack when you are tired, under the influence of alcohol, drugs or intoxicating medication.
- DO NOT lift or support vehicles with jack and do not use jack as a load sustaining device.
- DO NOT use jack for any purpose other than removal, transportation and installation of transmissions.
- DO NOT use jack without support chain or substitute an inferior form of restraint for the chain.
- DO NOT make any modifications to the jack, and DO NOT adjust or tamper with safety valve.
- DO NOT remove any labels from the jack. If labels are damaged or unclear replace them.
- Use a qualified person to lubricate and maintain the jack. DO NOT use brake fluid to top up hydraulic unit. Use Sealey hydraulic oil only.
- Before storing in safe area, ensure all parts are clean, free of grease and oil (especially saddle). Lower saddle to the lowest position.

2. INTRODUCTION & SPECIFICATIONS

Precision valve allows delicate adjustment when removing gearbox and realigning during replacement. Includes two chains for safe loading. Supplied with pulling hook and four castors for extra manoeuvrability in confined spaces. Fully adjustable saddle with forward and backward tilt.

SPECIFICATIONS:

Model No:	TJ1000F	TJ1500F
Rated Capacity:	1000kg	1500kg
Maximum Saddle Base Height:	730mm	810mm
Minimum Saddle Base Height:	185mm	170mm
Saddle Forward Tilt Angle:	60°	70°
Saddle Backward Tilt Angle:	20°	28°
Chassis Length/Width:	850/495mm	895/500mm
Saddle Length/Width:	200/180mm	250/200mm
Saddle Lateral Travel:	65mm	90mm
Saddle Pivot:	360°	360°

3. PRE-USE CHECK LIST

3.1. **IMPORTANT:** Before *EACH* use, check jack is in sound working order, use the following list to form an habitual checking procedure. Check that items are not: *damaged, broken, cracked, bent, malfunctioning, distorted, worn, loose, leaking, dirty, noisy or missing and that there is no damage to any welds.*

- | | | |
|---------------------------------|--|--------------------------------------|
| 1... . . . Saddle attachments | 6... . . . Cylinder/Hydraulic unit | 10... . . . Jack main frame |
| 2... . . . Saddle base | 7... . . . Stopper rings and cotter pins | 11... . . . Pump handle |
| 3... . . . Saddle tilt controls | 8... . . . All nuts and bolts | 12... . . . Swivel caster wheels |
| 4... . . . Tilt mechanism | 9... . . . All seals | 13... . . . Ring chain, hooks & pins |
| 5... . . . Piston rod | | |

WARNING! DO NOT use jack if any suspect part is found, or if it is believed to have been subjected to an abnormal load or shock. Immediately remove from service and contact your authorised service agent.

3.2. **IMPORTANT:** Before using the jack for the first time, purge the hydraulic circuit in order to eliminate any air that may have accumulated in the system during transit.

- 3.2.1. Open the release valve by turning the release valve knob anti-clockwise.
- 3.2.2. Pump the jack handle up and down 15 to 20 times.
- 3.2.3. Turn the release valve knob clockwise to close the valve.

4. OPERATING INSTRUCTIONS

4.1. SADDLE TILT MECHANISM.

Adjusting the pitch and tilt of saddle will assist in safely supporting and transporting the transmission unit. The saddle (fig.1C) may be tilted forwards and backwards by turning handle (fig.1A) and moved to the left or right by turning handle (fig.1B).

- WARNING! Before use ensure you have read, understood and apply Section 1 safety instructions.**
- WARNING! Ensure vehicle is prepared correctly before attempting to use the Transmission Jack.**

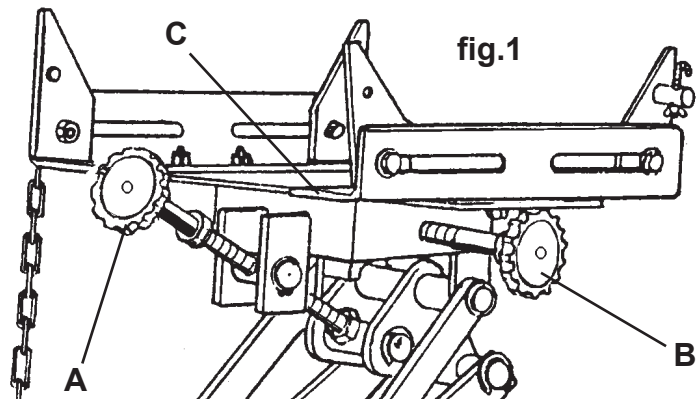

4.2. POSITIONING JACK BENEATH TRANSMISSION UNIT.

Before use ensure the transmission's weight and size does not exceed the capacity of the jack.

- 4.2.1. Ensure the vehicle from which the transmission is to be removed is correctly positioned, raised and locked on appropriate lift system.
- 4.2.2. Ensure there are no other persons around or under the vehicle.
- 4.2.3. Ensure saddle is in it's lowest position and use handle to transport and centrally position jack beneath vehicle's transmission.
- 4.2.4. Close the jack's release valve by turning the release valve knob clockwise.
- 4.2.5. Pump the jack handle up and down and raise the saddle.
- 4.2.6. When the saddle is just beneath the transmission, re-adjust alignment if necessary to centralise the saddle.
- 4.2.7. Adjust tilt handles (fig.1.A&B) for final positioning of the saddle.
- 4.2.8. Position the saddle attachments correctly and attach to the load for further security.
- 4.2.9. Tighten all saddle attachment nuts and bolts to secure the load whilst being lowered.

4.3. LOWERING THE TRANSMISSION UNIT.

- WARNING! Ensure the load is central and stable on the jack saddle before attempting to lower the load.**
- 4.3.1. **SLOWLY** turn the release valve knob anti-clockwise to *GENTLY* lower the saddle to the lowest height before attempting to transport the transmission unit.
- * **IMPORTANT:** Speed of lowering is controlled by the release valve. The more the release valve knob is turned, the more rapid the jack's descent. Ensure the jack's descent is slow and controlled to avoid the risk of sudden dropping, which could be very dangerous.

4.4. TRANSPORTING THE TRANSMISSION UNIT.

- WARNING! Ensure that you have read, understood and apply Section 1 safety instructions.**
- 4.4.1. Ensure the jack saddle is fully lowered, then secure the load by placing the support chain over the transmission, pull taut and engage into slot on opposite side of the saddle attachments. Tighten all nuts.
- 4.4.2. Using the pulling hook, transport the load over level and solid ground, preferably concrete, ensure the floor is swept clean beforehand.
- 4.4.3. Be diligent by continually monitoring the load in transit. Keep all other persons at a safe distance.
- ▲ **DANGER! DO NOT use on tarmacadam, or any soft surface as jack may sink or topple. Serious personal injury, possibly fatal may result.**
- ▲ **DANGER! If jack tips or leans STOP WHAT YOU ARE DOING. MOVE QUICKLY TO A SAFE DISTANCE. DO NOT TRY TO HOLD OR STEADY JACK.**

4.5. RE-INSTALLING A TRANSMISSION UNIT.

To transport, reposition beneath a vehicle, and to raise a load up, reverse the procedures outlined above.

5. MAINTENANCE

IMPORTANT: Only fully qualified personnel should attempt maintenance or repair.

- 5.1. When the jack is not in use, the saddle must be in its lowest position to minimise ram and piston corrosion. Turn the handle back to its storage position for safety.
- 5.2. Keep the jack clean and wipe off any oil or grease. Lubricate all moving parts with acid free oil, and grease tilt mechanism regularly.
- 5.3. To check the hydraulic oil level, fully lower the jack and the handle and remove the oil filler plug on top of the cylinder. The correct oil level should be just below the filler opening. If oil level is low, fill as required. Make sure that dirt is not allowed to enter the hydraulic system. Carefully pump unloaded jack 5 or 6 times to expel any air and then refit oil filler plug.

NOTE: Only a good quality Jack oil, such as SEALEY HYDRAULIC JACK OIL must be used, DO NOT use brake fluid, or any other fluid, other than hydraulic jack oil, as this may cause serious damage to the jack and will invalidate the warranty.

- 5.4. Before each use check list to ensure components are not damaged, broken, cracked, bent, malfunctioning, distorted, worn, loose, leaking, dirty, noisy or missing and that welds are not visibly damaged (see Section 3.1). If any suspect item is found, remove jack from service immediately and take necessary action to remedy the problem and/or contact your authorised service agent.
DO NOT use the jack if it is believed to have been subjected to abnormal load or shock. Inspect and take appropriate action.
- 5.5. Periodically check the pump piston and piston rod for signs of corrosion. Clean exposed areas with a clean oiled cloth.

IMPORTANT: NO RESPONSIBILITY IS ACCEPTED FOR INCORRECT USE OF THE MACHINE.

Hydraulic products are only repaired by local service agents. We have service/repair agents in all parts of the UK. **DO NOT RETURN JACKS TO US.** Please telephone 01284 757500 to obtain address and telephone number of your local agent. If Jack is under guarantee please contact your dealer.

De-commissioning the jack: Should the jack become completely unserviceable and require disposal, draw off the oil into an approved container and dispose of the jack and the oil according to local regulations.

6. TROUBLESHOOTING

IMPORTANT! Although the following may identify a problem, in most cases the problem must be resolved by your authorised service agent.

PROBLEM	CAUSE	SOLUTION
Jack will not lift.	No hydraulic oil or defective suction valve, delivery valve or release valve is open.	Contact authorised service agent. Close delivery valve.
Jack will only lift halfway.	Hydraulic oil level low.	Refill (see section 5.3. above).
Raised load will not hold.	Defective valves or defective piston packing.	Contact authorised service agent.
Poor lifting.	Defective plunger packing.	Contact authorised service agent.
Saddle tilt knob too tight.	Bolts and nuts may be bent or rusted.	Check, clean, oil or replace items.

Parts support is available for this product.

To obtain a parts listing and/or diagram, please log on to www.sealey.co.uk, email sales@sealey.co.uk or phone 01284 757500.

NOTE: It is our policy to continually improve products and as such we reserve the right to alter data, specifications and component parts without prior notice.

IMPORTANT: No liability is accepted for incorrect use of this product.

WARRANTY: Guarantee is 12 months from purchase date, proof of which will be required for any claim.

INFORMATION: For a copy of our latest catalogue and promotions call us on 01284 757525 and leave your full name and address, including postcode.



Sole UK Distributor, Sealey Group,
Kempson Way, Suffolk Business Park,
Bury St. Edmunds, Suffolk,
IP32 7AR



01284 757500



www.sealey.co.uk



01284 703534



sales@sealey.co.uk