



INSTRUCTIONS FOR: COMPACT AUTO INTELLIGENT BATTERY CHARGER-9-CYCLE 6/12V MODEL NO: SMC03.V2

Thank you for purchasing a Sealey product. Manufactured to a high standard this product will, if used according to these instructions and properly maintained, give you years of trouble free performance.



IMPORTANT: PLEASE READ THESE INSTRUCTIONS CAREFULLY. NOTE THE SAFE OPERATIONAL REQUIREMENTS, WARNINGS, AND CAUTIONS. USE THIS PRODUCT CORRECTLY, AND WITH CARE FOR THE PURPOSE FOR WHICH IT IS INTENDED. FAILURE TO DO SO MAY CAUSE DAMAGE AND/OR PERSONAL INJURY AND WILL INVALIDATE THE WARRANTY.

1. SAFETY INSTRUCTIONS

1.1 ELECTRICAL SAFETY

WARNING! It is the responsibility of the owner and the operator to read, understand and comply with the following: You must check all electrical products, before use, to ensure that they are safe. You must inspect power cables, plugs, sockets and any other connectors for wear or damage. You must ensure that the risk of electric shock is minimised by the installation of appropriate safety devices. A Residual Current Circuit Breaker (RCCB) should be incorporated in the main distribution board. We also recommend that a Residual Current Device (RCD) is used. It is particularly important to use an RCD with portable products that are plugged into a supply which is not protected by an RCCB. If in any doubt consult a qualified electrician. You may obtain a Residual Current Device by contacting your Sealey dealer. You must also read and understand the following instructions concerning electrical safety.

1.1.1 The **Electricity at Work Act 1989** requires that all portable electrical appliances, if used on business premises, are tested by a qualified electrician, using a Portable Appliance Tester (PAT), at least once a year.

1.1.2 The **Health & Safety at Work Act 1974** makes owners of electrical appliances responsible for the safe condition of those appliances and the safety of the appliance operators. If in any doubt about electrical safety, contact a qualified electrician.

1.1.3 Ensure that the insulation on all cables and on the appliance is safe before connecting it to the power supply. See 1.1.1 and 1.1.2 and use a Portable Appliance Tester.

1.1.4 Ensure that cables are always protected against short circuit and overload.

1.1.5 Regularly inspect power supply cables and plugs for wear or damage and check all connections to ensure that none are loose.

1.1.6 **Important:** Ensure that the voltage marked on the appliance matches the power supply to be used and that the plug is fitted with the correct fuse - see fuse rating to right.

1.1.7 **DO NOT** pull or carry the appliance by the power cable.

1.1.8 **DO NOT** pull the plug from the socket by the cable.

1.1.9 **DO NOT** use worn or damaged cables, plugs or connectors. Immediately have any faulty item repaired or replaced by a qualified electrician. When a BS 1363/A UK 3 pin plug is damaged, cut the cable just above the plug and dispose of the plug safely. Fit a new plug according to the following instructions (UK only).

- a) **Connect the GREEN/YELLOW earth wire to the earth terminal 'E'.**
- b) **Connect the BROWN live wire to the live terminal 'L'.**
- c) **Connect the BLUE neutral wire to the neutral terminal 'N'.**
- d) **After wiring, check that there are no bare wires, all wires have been correctly connected, the cable outer insulation extends beyond the cable restraint and that the restraint is tight.**

Double insulated products, which are always marked with this symbol , are fitted with live (brown) and neutral (blue) wires only. To rewire, connect the wires as indicated below. **DO NOT** connect either wire to the earth terminal.

1.1.10 If an extension reel is used it should be fully unwound before connection. A reel with an RCD fitted is preferred since any appliance plugged into it will be protected. The cable core section is important and should be at least 1.5mm², but to be absolutely sure that the capacity of the reel is suitable for this product and for others which may be used in the other output sockets, we recommend the use of 2.5mm² section cable.

1.2 GENERAL SAFETY

WARNING! DO NOT USE ON ANY OTHER BATTERIES APART FROM SEALED LEAD ACID BATTERIES.

WARNING! Disconnect the charger from the mains power before servicing or performing any maintenance.

✓ Disconnect the charger from the mains power before connecting to, or disconnecting from, the battery.
✓ Maintain the charger in good condition (use an authorised service agent only).

WARNING! Charger has components such as a switch which may cause sparks or arcs. When using the charger in a garage or workshop, make sure it is in a safe location.

✓ Keep the charger clean for best and safest performance.

WARNING! Ensure there are no sources of ignition near the work area i.e. naked flames, cigarettes, flame heaters etc as the charging process produces explosive gases.

WARNING! Ensure the working area is well ventilated as the gases produced are explosive.

✓ Locate the charger in a suitable work area. Keep area clean and tidy and free from unrelated materials, and ensure there is adequate lighting.

✓ Wear approved safety eye protection (standard spectacles are not adequate).

✓ Remove ill fitting clothing. Remove ties, watches, rings, and other loose jewellery, and contain long hair.

✓ Read vehicle manufacturer's instructions manual to check for any specific battery charging information.

✓ Disconnect the battery from the vehicle and move it to a safe, dry level area for charging. If the battery cannot be removed from the vehicle refer to manufacturer's hand book.

✓ Clean the charger clamps and battery terminals to remove any oxidation.

✓ Ensure the correct clamp polarity is observed when connecting to the battery. **Positive** is indicated by (+) and is Red, **negative** is indicated by (-) and is black.

✓ Keep children and unauthorised persons away from the working area.

✗ **DO NOT** pull or carry the charger by its power supply lead. Products must not be pulled or carried by their output cables.

✗ **DO NOT** pull power plugs from sockets by the power cable.

- X **DO NOT** use worn or damage leads, plugs or connections. Immediately replace or repair by qualified persons. A U.K. 3 pin plug with ASTA/BS approval is fitted. In case of damage, cut off and fit a new plug according to 1.1.9.
- X **DO NOT** attempt to charge a non-rechargeable battery.
- X **DO NOT** use the charger for any purpose other than that for which it is designed.
- X **DO NOT** allow the charger terminal clamps to touch each other when the power is on. Remember that gases are produced which may ignite if sparks occur.
- X **DO NOT** place the charger inside the vehicle. Remove the battery to a safe distance for charging.
- X **DO NOT** get the charger wet or use in damp or wet locations or areas where there is condensation.
- X **DO NOT** operate the charger if damaged.
- X **DO NOT** charge the battery with the engine running.
- X **DO NOT** attempt to modify or open the charger.
- ✓ When not in use unplug from the mains power supply and store in a safe, dry, secure area.
- **WARNING!** *Be vigilant and cautious during the operation of battery charging as the electrolyte is highly corrosive and any gases emitted are explosive.*
- X **DO NOT** allow untrained persons to operate the charger. This appliance is not intended for use by persons with reduced physical, sensory or mental capabilities, or lack of experience and knowledge, unless they have been given instruction concerning the use of the appliance and are supervised by a person responsible for their safety.
- ✓ Keep children and unauthorised persons away from the working area. Children must not use the charger and should be constantly supervised to ensure they do not play with the charger.

- ✓ Wear safety eye protection and protective clothing. Avoid touching eyes while working near battery.
- ✓ Have fresh water and soap nearby in case battery acid contacts skin, clothing or eyes.
- ✓ Wash immediately with soap and water if battery acid contacts skin or clothing. If acid enters eye, flush eye immediately with cool, clean running water for at least 15 minutes and seek immediate medical attention.
- ✓ Remove personal metallic items such as rings, bracelets, necklaces and watches. A lead acid battery can produce a short-circuit current high enough to weld a ring or similar to metal, which would cause severe burns.
- ✓ Ensure hands and clothing (especially belts) are clear of fan blades and other moving or hot parts of engine. Remove ties and contain long hair.
- X **DO NOT** smoke or allow a spark or flame in the vicinity of battery or engine.

2. INTRODUCTION

Fully automatic 9-cycle switch mode charger and maintainer designed for charging a variety of batteries: SLA, WET, AGM, VRLA and LEAD CALCIUM. You know exactly how the charger is performing; the LED display indicates charging or maintenance phase. Charger will recover slightly sulphated batteries and may rescue drained batteries. Supplied with multi-fit charger cables featuring crocodile clips, eyelets, vehicle accessory plug and hard-wired terminals incorporating a water tight plug and socket for permanent installation. For motorcycles and cars.

SPECIFICATION

MODEL NO:	SMC03.V2
Input Voltage	230V
Output Voltage	6V/12V
Type	9-Cycle 6/12V
Input Current	0.45A
Efficiency	>80%
Battery Types	SLA, WET, AGM, VRLA, Lead Calcium
Charging Current	4A
Back Current Drain	<1Ah/month
Ambient Temperature	-20°C to +50°C
Dimensions (LxWxH)	233 x 82 x 46.5mm
Housing protection	IP44
Weight:	0.54 kg

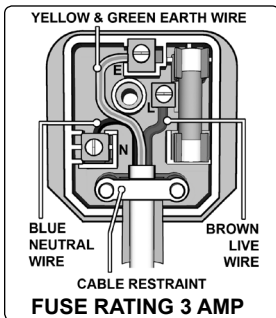

DANGER! BE AWARE, LEAD ACID BATTERIES GENERATE EXPLOSIVE GASES DURING NORMAL BATTERY OPERATION. FOR THIS REASON, IT IS VERY IMPORTANT TO READ AND FOLLOW THESE INSTRUCTIONS CAREFULLY, EACH TIME YOU USE THE CHARGER.



Follow these instructions and those published by the battery and vehicle manufacturers and the manufacturer of any equipment you intend to use in the vicinity of the battery. Remember to review warning marks on all products and on engines.

1.3 PERSONAL PRECAUTIONS

- ✓ Ensure there is another person within hearing range of your voice, or close enough to come to your aid, should a problem arise when working near a lead acid battery.

3. CONNECTION TO BATTERY

NOTE: THE CHARGER SHOULD BE CONNECTED TO THE BATTERY OR THE VEHICLE ACCESSORY SOCKET, **BEFORE** CONNECTING TO THE MAINS SUPPLY.

- 3.1 The output cable from the charger terminates in a socket into which three alternative leads can be connected. (see Fig. 1)
 - 3.1.1 One lead set (A) has two colour coded battery clamps which can be quickly attached to and detached from the battery posts. The other end of the cable terminates with a plug for connection to the charger lead socket.
 - 3.1.2 The second lead (B) can be connected to the vehicle via the vehicle accessory socket. The other end of the cable terminates with a plug for connection to the charger lead socket.
 - 3.1.3 The third lead (C) is for semi permanent connection to the battery via eyelets. The other end of the cable terminates with a plug for connection to the charger lead socket.

Fig.1**BATTERY CHARGER FOR 12V/6V LEAD ACID BATTERIES**

Warning! Explosive gases- prevent flames and sparks. Before charging, study instruction sheet
 Disconnect supply before making or breaking DC connections. Provide for good ventilation.



BS 1363/A
 UK 3 pin plug



Socket

BATTERY CHARGER FOR 12V/6V LEAD ACID BATTERIES

Model: **SMC03.V2** Input: 220-240VAC 0.45A, 50-60Hz. Output: 12V, 6V, DC, 4A. 9-step charging
 For WET/AGM/GEL batteries. High frequency switch mode technology.

14.4V 1A, 1.2-20Ah 14.4V 4A, 12.80Ah 14.7V 4A, 12.80Ah 7.5V 4A, 12.80Ah

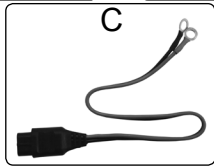
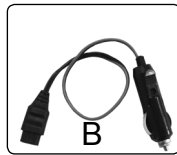
**3.2 CHARGING A NEGATIVE EARTHED BATTERY:**

3.2.1 Ensure that the black clamp on the clamp lead is not touching the battery or the fuel line.

3.2.2 Connect the positive (+) red clamp to the positive (+) battery post and connect the negative (-) black clamp to the negative (-) battery post or vehicle chassis.

3.3 CHARGING A POSITIVE EARTHED BATTERY:

3.3.1 Ensure that the red clamp on the clamp lead is not touching the battery or the fuel line.

3.3.2 Connect the negative (-) black clamp to the negative (-) battery post and connect the positive (+) red clamp to the positive (+) battery post or vehicle chassis.

3.4 BATTERY NOT CONNECTED TO A VEHICLE.

3.4.1 Connect the (+) red clamp to the positive (+) battery post and connect the (-) black clamp to the negative (-) battery post.

3.5 PERMANENT CONNECTION TO VEHICLE USING EYELET LEAD.

3.5.1 Connect the eyelet on the red (+) wire to the positive (+) battery terminal and connect the eyelet on the black (-) wire to the negative (-) battery terminal.

4. OPERATION

NOTE: Connect the charger output clamps to the battery terminals as described in Section 3 before plugging in to the mains power supply.

4.1 CONNECT CHARGER TO MAINS POWER SUPPLY.

4.1.1 Plug the charger into the mains power supply and switch on. The green power LED will illuminate. See Fig.2.

4.2 CHARGING MODE SELECTION.

Repeatedly pressing the MODE button will cycle the charger through the following options:- MODE1, MODE2, MODE3, MODE4 and MODE5. Stop pressing when the LED adjacent to the desired mode illuminates.

4.2.1 If the Mode button is pressed again during charging the charger will switch to the next charging mode and will function in that mode. However, once the battery is fully charged and if the charger remains connected, the charger will switch to trickle charge mode and will remain in this mode even if the user selects another mode. This protects the battery from being damaged.

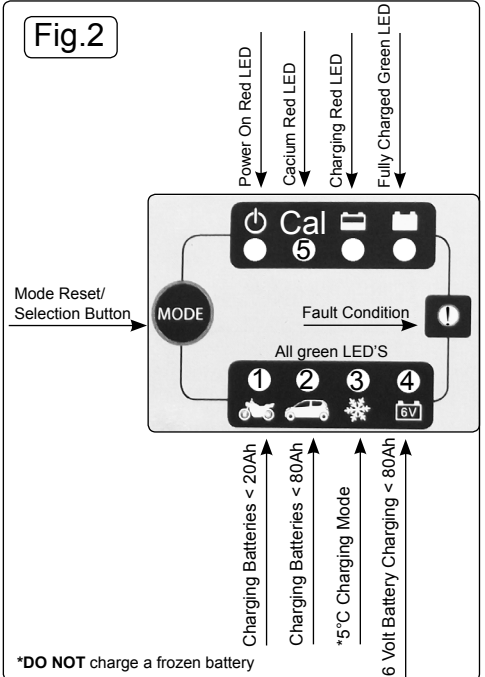
Fig.2**4.3 MODE 1 DESCRIPTION (*14.4V/1.0A)**

4.3.1 This mode is suitable for charging small batteries with a capacity below 20Ah. Press the MODE button until the LED adjacent to the motorcycle symbol is illuminated. Charging will automatically begin with a current of $0.8A \pm 10\%$ and the 'charging' LED will illuminate. This LED will remain on throughout the entire charging process until the battery is fully charged up to $*14.4V \pm 0.25V$. At this stage the 'charging' LED will illuminate and the 'fully charged' LED will extinguish. The trickle charge current now becomes available for battery maintenance.

4.4 MODE 2 DESCRIPTION (*14.4V/4.0A)

4.4.1 This mode is mainly for charging large batteries with a capacity over 14Ah in normal conditions. Press the MODE button until the LED adjacent to the car symbol is illuminated. Charging will automatically begin with a current of $3.8A \pm 10\%$ and the 'charging' LED will illuminate. This LED will remain on throughout the entire charging process until the battery is fully charged up to $*14.4V \pm 0.25V$. At this stage the 'charging' LED will turn off and the 'fully charged' LED will illuminate. The trickle charge current now becomes available for battery maintenance.

4.5 MODE 3 DESCRIPTION (*14.7/4.0A)

4.5.1 This mode is mainly for charging large batteries with a capacity over 14Ah in cold conditions or for charging several AGM batteries with a capacity over 20Ah. Press the MODE button until the LED adjacent to the ice crystal symbol is illuminated. Charging will automatically start with a set delay with a current of $3.8A \pm 10\%$ and the 'charging' LED will illuminate. This LED will remain on throughout the entire charging process until the battery is fully charged up to $*14.7V \pm 0.25V$. At this stage the 'charging' LED will extinguish and the 'fully charged' LED will illuminate. The trickle charge current now becomes available for battery maintenance.

4.6 MODE 4 DESCRIPTION (7.5/4A)

4.6.1 This mode is mainly for charging all types of 6 volt batteries with a capacity over 14Ah. Press the MODE button until the LED adjacent to the 6V battery symbol is illuminated. Charging will automatically start with a set delay and the 'charging' LED will illuminate. This LED will remain on throughout the entire charging process until the battery is fully charged up to $7.5V \pm 0.25V$. At this stage the 'charging' LED will extinguish and the 'fully charged' LED will illuminate. The trickle charge current now becomes available for battery maintenance.

4.7 MODE 5 DESCRIPTION (CaI)

4.7.1 This mode is for lead calcium or a battery below $*10.5$ volts with no capacity to absorb charging current, the charger will automatically raise the output up to $*17$ volts. The Mode 5 LED will illuminate and flash, the 'charging' LED will illuminate. If the battery cannot be recovered within 2 hours the "Fault" (I) LED will illuminate. The battery may require replacing.

4.8 FAULT PROTECTION

4.8.1 In the case of a short circuit, open circuit, reversed polarity or battery voltage below $*7.5V \pm 0.5$, the charger will turn off the electronic system and revert to standby mode. Additionally the "Fault" (I) LED will illuminate. The fault must be identified and resolved before any of the charging modes are initiated.

4.9 OVERHEATING PROTECTION

4.9.1 If the charger becomes too hot during the charging process or due to extreme ambient temperatures the power output is automatically reduced to a trickle charge to protect the unit. Once the temperature drops the charger will increase the power output automatically.

5. DESCRIPTION OF CHARGING PHASES

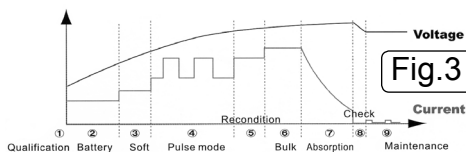

5.1 The **SMC03.V2** charger has a nine step fully automatic charging cycle as shown in Fig.3 above, which is indicative of the typical charging curve for a battery.

5.2 **PHASE 1 through 5 DIAGNOSIS & RECOVERY:** As soon as one of the charging modes is selected the diagnostic function automatically detects the condition of the battery i.e. voltage. If the voltage of a deeply discharged battery is over $*7.5V \pm 0.5V$ the charger begins to pulse charge with a small current to recover it. Pulse charging ceases when the voltage reaches $*10.5V \pm 0.5V$. If the voltage detected is over $*10.5V \pm 0.5V$ the charger skips pulse charging and switches to the preselected charging mode.

5.3 **PHASE 6 BULK:** Up to 80% of the charge is delivered in this phase.

5.4 **PHASE 7 ABSORPTION:** A constant low charging current raises the voltage from $*14.1V$ to $14.4V$ over a period of time without gassing the battery. In this phase complete charging up to almost 100% is achieved. When full charge is reached the charger switches to phase 8 and 9.

5.5 **PHASE 8 & 9 MAINTENANCE CHARGE:** If the battery is loaded and/or the voltage across the terminals drops below $*12.8V$, the charger starts a maintenance charging pulse at a constant $0.8A$ until the voltage reaches $*14.4V$ at which point the maintenance charge is turned off. The charger continues to monitor the battery condition and will cycle between trickle charge and maintenance charge indefinitely to keep the battery in peak condition. The charger can be left connected to the battery in order to perform this maintenance function.

Note!

Figures marked thus * are for 12 volt batteries and all figures are offered as a guide only. The charger is automatic and requires no measurements by the user.

6. MAINTENANCE

6.1 This charger requires no specific maintenance other than cleaning which should be done with a dry cloth or a tissue. **DO NOT** use any solvents or cleaning agents on the casing.

6.2 Ensure that the charger is unplugged from the mains before installing or performing any maintenance.

Environmental Protection.



Recycle unwanted materials instead of disposing of them as waste. All tools, accessories and packaging should be sorted, taken to a recycle centre and disposed of in a manner which is compatible with the environment.



When the product is no longer required, it must be disposed of in an environmentally protective way.

NOTE: It is our policy to continually improve products and as such we reserve the right to alter data, specifications and component parts without prior notice.

IMPORTANT: No liability is accepted for incorrect use of this product.

WARRANTY: Guarantee is 12 months from purchase date, proof of which will be required for any claim.

INFORMATION: For a copy of our latest catalogue and promotions call us on 01284 757525 and leave your full name and address, including postcode.



Sole UK Distributor, Sealey Group,
Kempson Way, Suffolk Business Park,
Bury St. Edmunds, Suffolk,
IP32 7AR

01284 757500

www.sealey.co.uk

01284 703534

sales@sealey.co.uk