

Thank you for purchasing a Sealey product. Manufactured to a high standard this product will, if used according to these instructions and properly maintained, give you years of trouble free performance.



IMPORTANT: PLEASE READ THESE INSTRUCTIONS CAREFULLY. NOTE THE SAFE OPERATIONAL REQUIREMENTS, WARNINGS & CAUTIONS. USE THE PRODUCT CORRECTLY AND WITH CARE FOR THE PURPOSE FOR WHICH IT IS INTENDED. FAILURE TO DO SO MAY CAUSE DAMAGE OR PERSONAL INJURY AND WILL INVALIDATE THE WARRANTY. PLEASE KEEP INSTRUCTIONS SAFE FOR FUTURE USE.

1. SAFETY INSTRUCTIONS

1.1. ELECTRICAL SAFETY.

WARNING! It is the user's responsibility to read, understand and comply with the following:

You must check all electrical equipment and appliances to ensure they are safe before using. You must inspect power supply leads, plugs and all electrical connections for wear and damage. You must ensure the risk of electric shock is minimised by the installation of appropriate safety devices. An RCCB (Residual Current Circuit Breaker) should be incorporated in the main distribution board. We also recommend that an RCD (Residual Current Device) is used with all electrical products. It is particularly important to use an RCD with portable products that are plugged into an electrical supply not protected by an RCCB. If in doubt consult a qualified electrician. You may obtain a Residual Current Device by contacting your Sealey dealer. **You must** also read and understand the following instructions concerning electrical safety.

- 1.1.1. The **Electricity At Work Act 1989** requires all portable electrical appliances, if used on business premises, to be tested by a qualified electrician, using a Portable Appliance Tester (PAT), at least once a year.
- 1.1.2. The **Health & Safety at Work Act 1974** makes owners of electrical appliances responsible for the safe condition of the appliance and the safety of the appliance operator. **If in any doubt about electrical safety, contact a qualified electrician.**
- 1.1.3. Ensure the insulation on all cables and the product itself is safe before connecting to the mains power supply. See 1.1.1. & 1.1.2. above and use a Portable Appliance Tester (PAT).
- 1.1.4. Ensure that cables are always protected against short circuit and overload.
- 1.1.5. Regularly inspect power supply, leads and plugs for wear and damage and all electrical connections to ensure that none is loose.
- 1.1.6. **Important:** Ensure the voltage marked on the product is the same as the electrical power supply to be used and check that plugs are fitted with the correct capacity fuse. A 13 amp plug may require a fuse smaller than 13 amps for certain products (*subject to 1.1.10. below*) see fuse rating at right.
- 1.1.7. DO NOT pull or carry the powered appliance by its power supply lead.
- 1.1.8. DO NOT pull power plugs from sockets by the power cable.
- 1.1.9. DO NOT use worn or damaged leads, plugs or connections. Immediately replace or have repaired by a qualified electrician. A U.K. 3 pin plug with ASTA/BS approval is fitted. In case of damage, cut off and fit a new plug according to the following instructions (discard old plug safely). (UK only - see diagram at right). **Ensure the unit is correctly earthed via a three-pin plug.**

a) **Connect the GREEN/YELLOW earth wire to the earth terminal 'E'.**

b) **Connect the BROWN live wire to live terminal 'L'.**

c) **Connect the BLUE neutral wire to the neutral terminal 'N'.**

After wiring, check that there are no bare wires, that all wires have been correctly connected, that the cable outer insulation extends beyond the cable restraint and that the restraint is tight.

Double insulated products are often fitted with live (BROWN) and neutral (BLUE) wires only.

Double insulated products are always marked with this symbol . **To re-wire, connect the brown & blue wires as indicated above. DO NOT connect the brown or blue to the earth terminal.**

- 1.1.10. Some products require more than a 13 amp electrical supply. In such a case, **NO** plug will be fitted. **You must** contact a qualified Electrician to ensure a 30 amp fused supply is available. We recommend you discuss the installation of a industrial round pin plug and socket with your electrician.
- 1.1.11. **Cable extension reels.** When a cable extension reel is used it should be fully unwound before connection. A cable reel with an RCD fitted is recommended since any product which is plugged into the cable reel will be protected. The section of the cores in the cable reel is important. We suggest 1.5mm² section cable as a minimum but to be absolutely sure that the capacity of the cable reel is suitable for this product and for others that may be used in the other output sockets, we recommend the use of 2.5mm² section cable.

1.2 GENERAL SAFETY

- ✓ Familiarise yourself with the product's application and limitations, as well as the specific potential hazards peculiar to the machine.
- **WARNING!** Ensure all Health and Safety, local authority, and general workshop practice regulations are strictly adhered to.
- **WARNING!** Disconnect from the mains power supply before changing accessories, servicing or performing any maintenance.
- **WARNING! DO NOT** sand any materials containing asbestos.
- **WARNING!** Wear approved safety eye / face protection. If dust is generated respiratory protection must be worn.
- ✓ Maintain the sander and keep in good condition (use an authorised service agent).
- ✓ Check the alignment of moving parts regularly, for safest performance keep the sander clean at all times.
- ✓ Use the correct type and size of sanding disc for this sander.
- ✓ Before each use check sanding disc for condition. If worn or damaged replace immediately.
- ✓ Replace or repair damaged parts. Use genuine parts only. Non-authorized parts are dangerous and will invalidate the warranty.
- ✓ Locate the sander in a suitable area, keep area clean, uncluttered and ensure there is adequate lighting.
- ✓ The sander is for indoor use only. DO NOT get the sander wet or use in a damp location.
- ✓ Ensure the sander is situated on a solid work surface, adequate for supporting the weight of both the sander and the workpiece.
- ✓ Ensure there are no flammable or combustible materials near the work area.
- ✓ Remove ill fitting clothing, ties and loose jewellery, and tie back long hair.
- ✓ Maintain correct balance and footing, ensure the floor is not slippery and wear non-slip rubber soled footwear.
- ✓ Keep hands and body clear of the worktable when operating the sander.
- ✓ Ensure there are no nails, screws etc. protruding from the surface to be sanded.
- x **DO NOT** operate the sander when you are tired, under the influence of alcohol, drugs or intoxicating medication.
- x **DO NOT** leave the sander running unattended.
- ✓ Hold workpiece firmly, avoiding hand positions where a slip may cause your hand to come into contact with the sanding disc.

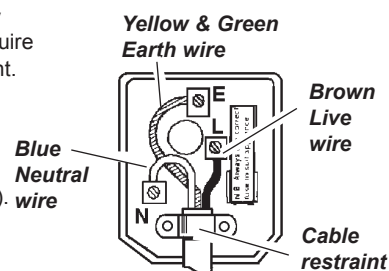

**FUSE RATING
13 AMP FUSE**

- x **DO NOT** modify or change the sander motor for one with a different rating.
- x **DO NOT** turn the sander on until work table is clear of all objects, wood scraps etc.
- x **DO NOT** touch the sanding disc whilst operating, or whilst sander is plugged into the mains power.
- x **DO NOT** switch the sander on while the workpiece is in contact with the sanding disc.
- x **DO NOT** operate the sander if any parts are damaged or missing as this may cause failure or possible personal injury.
- x **DO NOT** allow children or untrained persons to operate the sander. Keep them away from the work area.
- x **DO NOT** use the sander for any purpose other than wood finishing.
- ✓ When not in use, unplug from the mains power supply and store in a childproof location.

2. TECHNICAL SPECIFICATION

Model	SM31.V3	Dust Extraction Port.	Ø52mm
Disc Diameter	Ø305mm	Motor	750W - 230V
Disc Speed	1450rpm	Weight	29.5kg
Table	156 x 438mm		
Table Tilt.	45°		

3. ASSEMBLY

- 3.1. Unpack the sander and check contents against the list below. If there are any damaged or missing parts contact your supplier immediately.
Contents: • Sander Assembly • Table • Mitre Gauge • Hex. Key
 - 3.2. Remove various screws (fig.1.parts1-4) from the sander assembly, fit table (A) in position and retain by replacing screws. The table should always have at least 1.6mm clearance from the sanding disc, adjustment can be made by loosening the six cross head bolts in the face of the table top.
 - 3.3. If a dust extraction system is available, connect it to the extraction port (diameter 52mm).
 - 3.4. The mitre gauge, when required, locates in the table groove.
- ☐ **WARNING!** Before use, the machine must be positioned on a stable, fireproof bench or table which is strong enough to take the weight of the machine and the workpiece. The sander is supplied with rubber feet, alternatively it can be bolted to a work surface. Failure to comply with this instruction could result in severe personal injury.

4. OPERATING INSTRUCTIONS

- 4.1. Ensure that you have read, understand and apply the safety instructions in Section 1.
☐ **WARNING!** Before each use rotate the sanding disc by hand to check it is undamaged and secure. Remove adjusting keys and wrenches before turning the machine on.
- 4.2. **Table adjustment**
 - 4.2.1. The table is adjustable through 45° by slackening the two locking lever handles (fig1.3.) - both right hand thread, adjusting the table to the required angle and then fully tightening both handles.
- 4.3. **Mitre gauge adjustment**
 - 4.3.1. The gauge is adjustable through ±45° by slackening the thumb screw, adjusting to required angle and tightening the thumb screw.
- 4.4. **Operating sander**
 - 4.4.1. Feed workpiece carefully into the sanding disc, work methodically and **DO NOT** force the sander to remove material faster than it was designed for. Hold workpiece with both hands and ensure that they are not in a position where they could slip up against the sanding disc.
 - 4.4.2. Ensure large workpieces are supported at table height.
 - 4.4.3. Turn sander off and make sure sanding disc is stationary before clearing scrap pieces from the table.

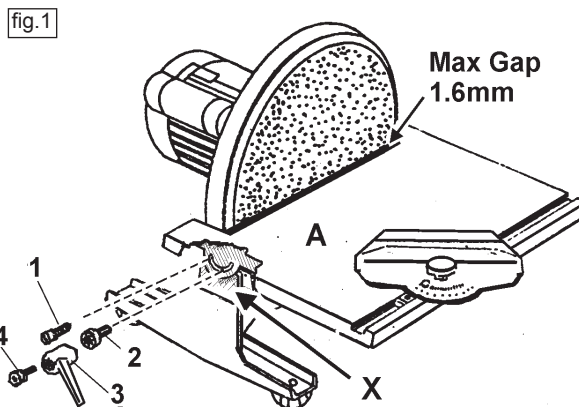

5. MAINTENANCE

- 5.1. The sander is maintenance free and only requires cleaning using a vacuum cleaner and brush.
- 5.2. Occasionally check sander over for loose fittings and to ensure sanding disc is secure.

NOTE: It is our policy to continually improve products and as such we reserve the right to alter data, specifications and component parts without prior notice.

IMPORTANT: No liability is accepted for incorrect use of this product.

WARRANTY: Guarantee is 12 months from purchase date, proof of which will be required for any claim.

INFORMATION: For a copy of our latest catalogue and promotions call us on 01284 757525 and leave your full name and address, including postcode.



Sole UK Distributor, Sealey Group,
Kempson Way, Suffolk Business Park,
Bury St. Edmunds, Suffolk,
IP32 7AR

☎ 01284 757500
☎ 01284 703534

🌐 www.sealey.co.uk
✉ sales@sealey.co.uk