

Thank you for purchasing a Sealey product. Manufactured to a high standard this product will, if used according to these instructions and properly maintained, give you years of trouble free performance.



**IMPORTANT: PLEASE READ THESE INSTRUCTIONS CAREFULLY. NOTE THE SAFE OPERATIONAL REQUIREMENTS, WARNINGS AND CAUTIONS. USE THIS PRODUCT CORRECTLY AND WITH CARE FOR THE PURPOSE FOR WHICH IT IS INTENDED. FAILURE TO DO SO MAY CAUSE DAMAGE AND/OR PERSONAL INJURY AND WILL INVALIDATE THE WARRANTY. PLEASE KEEP INSTRUCTIONS SAFE FOR FUTURE USE.**

### 1. SAFETY INSTRUCTIONS

- WARNING! Ensure Health & Safety, local authority, general workshop practice regulations are adhered to when using equipment.**
- WARNING! Installation site must be equipped with suitable fire extinguishers (water must not be used) and escape routes.**
- WARNING! Disconnect the air supply from the tank before changing accessories, servicing or performing any maintenance.**
- ✓ Maintain the tank in good condition (use an authorised service agent).
- ✓ Replace or repair damaged parts. Use genuine parts only. Unauthorised parts may be dangerous and will invalidate the warranty.
- ✓ Locate the tank in a suitable work area. Ensure the tank stands on a firm, level surface. Keep area clean and tidy and free from unrelated materials. Ensure the area is well ventilated and has adequate lighting.
- WARNING! Ensure specified air pressure is maintained and not exceeded.**
- ✓ Keep air hose away from heat, oil and sharp edges. Check air hose for wear before each use, and ensure that all connections are secure.
- WARNING! This tank is recommended for use only with degreasing solvents suitable for air operated tanks. Ensure you follow makers instructions for solvent use.**
- ✓ Ensure solvent flash point is above 140°F. We recommend you use Sealey solvent - contact your local dealer for details.
- ✓ Keep the tank clean. Remove and clean the tank filters regularly for best performance.
- WARNING! DO NOT SMOKE and keep sources of ignition, such as heaters, lamps, etc., away from the unit, together with flammable or combustible materials, as there is an explosion risk.**
- ✓ *When cleaning parts ensure that nothing in the tank, including any parts basket, is in a position that would prevent the lid from closing fully if and when the fusible link activates.*
- WARNING! DO NOT modify the lid or jam it open. Keep the lid and holding screws in place, tight and in good working order.**
- WARNING! DO NOT attempt to perform welding on the unit for any reason. Do not weld near the unit.**
- WARNING! Wear approved safety eye protection, mask and gloves. If solvent gets on skin or in eyes wash thoroughly with water and take any other action as required by the solvent instructions.**
- ✓ Remove ill fitting clothing, ties, watches, rings and other loose jewellery, contain long hair and wear appropriate protective clothing.
- ✓ Maintain correct balance and footing. Ensure the floor is not slippery and wear non-slip shoes.
- ✓ Keep non-essential persons away from the working area.
- ✓ In case of fire in tank, do not attempt to move unit or remove parts from tank. The lid is fusible and will automatically close extinguishing fire.
- ✓ Disconnect the unit from the air supply when not in use.
- x DO NOT use the tank for any purpose other than that for which it is designed.
- x DO NOT operate the tank if any parts are missing or damaged as this may cause failure and/or personal injury.
- x DO NOT over-fill the tank.
- x DO NOT modify or jam the parts washer lid open, as this will make the fusible fire link inoperative which is dangerous practice and will invalidate the warranty and your insurance.
- x DO NOT use air line to blow dry components in tank. Only use air gun supplied. DO NOT direct air gun at yourself or others.
- x DO NOT leave the parts washer operating unattended.
- ✓ When cleaning is complete, ensure all controls are in the 'off' position and that the air supply is disconnected.
- WARNING! It is owner's responsibility to ensure that there is no uncontrolled discharge of any fluids used with this unit and that appropriate arrangements have been made for correct disposal of waste in accordance with government/local authority regulations.**

### 2. INTRODUCTION & SPECIFICATION

Steel fabricated 65ltr reservoir and 50ltr one-piece tank. Mobile unit with two castors and two fixed wheels can be easily taken to work area. Air operated unit can be charged and used remotely without air supply for a limited period. Includes air blow gun for fast drying and brush for cleaning workpiece. Reservoir fitted with fluid level indicator and drain tap. Supplied with removable shelf and tray. Lid fitted with fusible link hinge which automatically snaps shut in the event of a fire.

#### SPECIFICATION

Model No: .....	SM224
Overall Height: .....	1040mm
Tank Height: .....	180mm
Tank Width: .....	710mm
Maximum Length: .....	775mm
Pump Output/hr: .....	140ltr
Supply: .....	Air
Operating Pressure: .....	40-60psi
Air Consumption: .....	6cfm
Air Inlet Ø: .....	1/4" BSP
Weight: .....	23kg
Max. Working Capacity: .....	55ltr



### 3. ASSEMBLY

As you unpack the product, check contents. Should there be any damaged or missing parts contact your supplier immediately.

- 3.1. Assemble the gate valve (A) which connects the tank to the reservoir, directly to the reservoir as shown in fig.1, ensuring that a rubber seal is fitted to both ends of the valve.
- 3.2. Screw the air regulator and safety valve assembly (B) to the reservoir as shown in fig.2 ensuring that the rubber seal provided is in place.
- 3.3. Assemble the two upper tank support arms (C) into the sockets provided on the tank but do not tighten the fittings yet.
- 3.4. Place the upper tank onto the support arms and lower it down until the tank outlet drops into the top of the gate valve (A). Fix the tank to the valve by tightening ring (Q) as shown in fig.4. Tighten the hex socket bolts at either end of the upper tank supports (C). Fit handle into support arm brackets (C) and tighten.
- 3.5. Mount the cleaning brush in its stowage position on the underside of the lid over to the left hand side. Feed the brush tube (T) through the hole in the righthand side of the tank and connect it to outlet (R) on the head of the regulator /safety valve assembly.

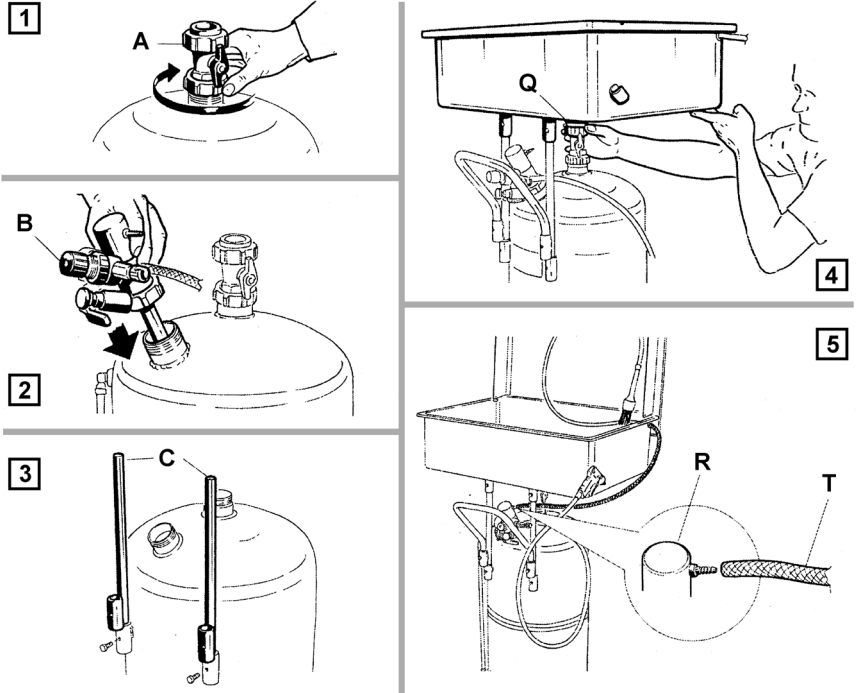

### 4. AIR SUPPLY

- 4.1. Ensure that the air regulator valve is closed before connecting the air supply.
- 4.2. An air pressure of 40-60psi and an available air volume of 6cfm will be required to operate the unit.
- ❑ **WARNING! Ensure air supply is clean and does not exceed 110psi. Too high an air pressure and/or unclean air will shorten the product life, and may be dangerous, causing possible damage and/or personal injury. Air supply must be equipped with regulator & water trap.**
- 4.3. Drain the air supply tank daily. Water in the air line will damage the unit.
- 4.4. Clean the air supply filter weekly. For recommended hook-up, see diagram to right.
- 4.5. Line pressure should be increased to compensate for unusually long air hoses (over 8 metres). The minimum hose internal diameter should be 10mm and fittings must have the same internal dimension.
- 4.6. Keep hose away from heat, oil and sharp edges. Check hoses for wear, and make certain that all connections are secure.
- 4.7. The air inlet connection is 1/4" BSP.

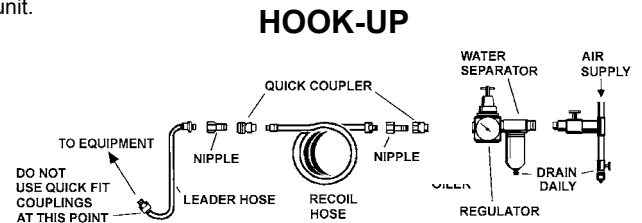

### 5. PREPARATION & USE

- 5.1 **Filling the unit with cleaning fluid.**
  - 5.1.1 Make sure that the drain cock at the base of the unit is closed as shown at (F) in fig.6.
  - 5.1.2 Turn the lever (D) to the right which is the air discharge position. This allows the fluid to drain more easily out of the upper tank and into the lower reservoir. See fig.7. Open the gate valve (E) by turning the lever to the vertical position.
  - 5.1.3 Shut the pressure regulator by pulling and turning the pressure regulator knob (G) anticlockwise. See fig.8.
  - 5.1.4 Pour cleaning fluid into the upper tank and allow it to drain down into the lower reservoir. Continue to fill the unit until the level has risen to the maximum mark on the level indicator tube.
  - 5.1.5 Before using the unit ensure that all filter grids are in place.
- ❑ **WARNING! Wear approved safety eye protection, mask and gloves. If solvent gets on skin or in eyes wash thoroughly with water and take any other action as required by the solvent instructions.**

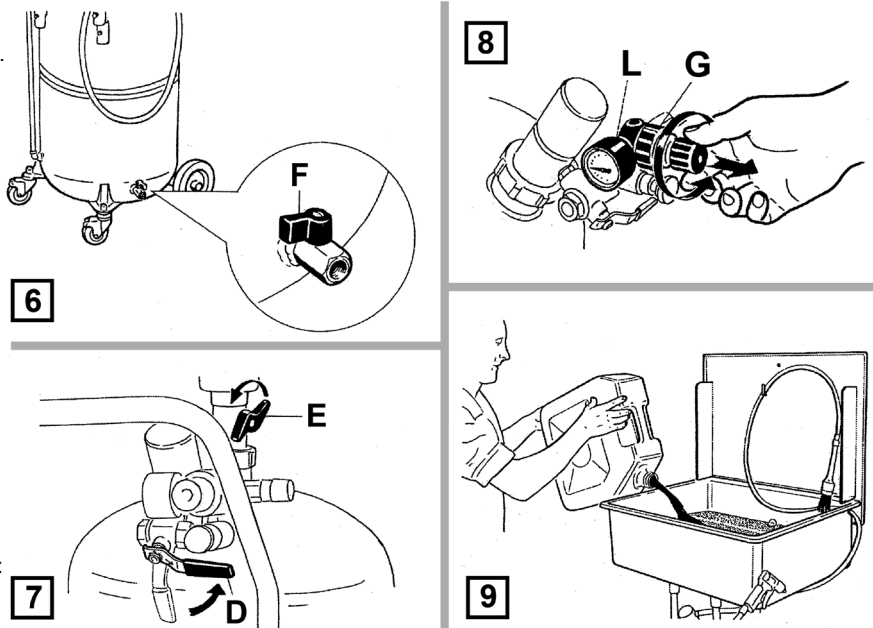

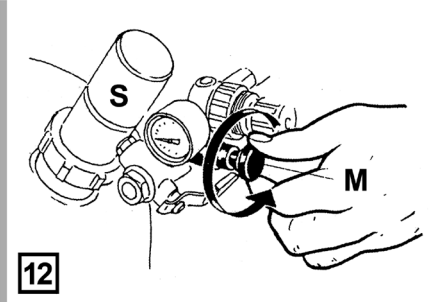
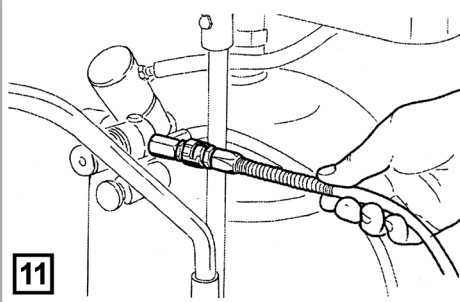
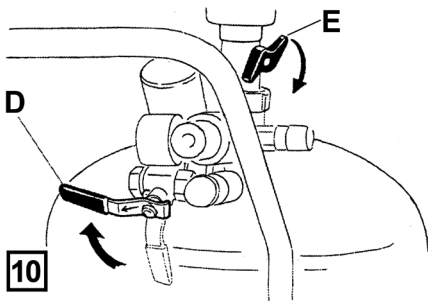

## 5.2 Commencing Brush Washing.

5.2.1 Close the gate valve (E) and turn lever (D) to the left as shown in fig.10.

5.2.2 Connect a compressed air line to the connector shown in fig.11.

5.2.3 Pre-set the air pressure by pulling and turning the air regulator knob clockwise until the gauge shows a pressure between 90 & 110psi.

5.2.4 Turn the flow regulator (M) anticlockwise until fluid flows from the brush. See fig.12.

## 5.3 Safety valve.

5.3.1 The fluid outlet head (S) shown in fig.12 is a movable, weighted item that acts as a safety valve. If the flow regulator (M) is opened too much, excess air will be discharged from underneath the head. Take care to set the flow regulator (M) to an adequate but not excessive flow of air.

## 5.4 Air Blow Gun.

5.4.1 The unit is also equipped with an air blow gun for drying components after cleaning. When the nozzle of the gun is twisted clockwise the gun is shut off. When the nozzle is twisted anticlockwise the gun is on. The first movement of the trigger produces a medium flow of air. When the trigger reaches its full travel the air flow changes to a more gentle blow.

## 5.5 Washing by dipping.

5.5.1 Open the gate valve (E) and turn lever (D) to the left as shown in fig.10. The cleaning fluid will rise from the reservoir into the tank and will be kept in constant motion by the air passing through the liquid itself.

5.5.2 The intensity of the agitation can be adjusted by means of the flow regulator (M).  
**WARNING! DO NOT allow excessive agitation to take place as this may cause splashing and overflowing of the tank.**

5.5.3 To turn the agitation off, close the gate valve and turn the lever (D) to the middle position.

5.5.4 To return the fluid to the reservoir, turn lever (D) to the right and open gate valve (E).

5.5.5 To empty the reservoir, open the drain cock (F).

**When cleaning parts ensure that nothing in the tank, including any parts basket, is in a position that would prevent the lid from closing fully if and when the fusible link activates.**

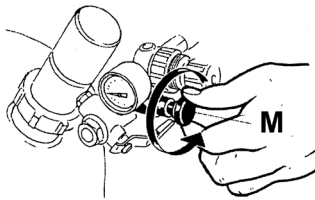

13

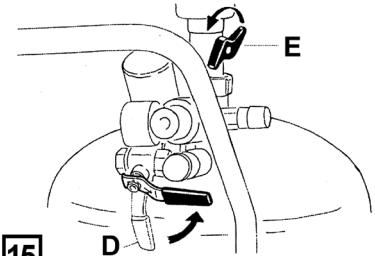

15

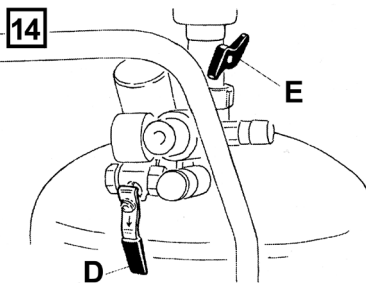

14

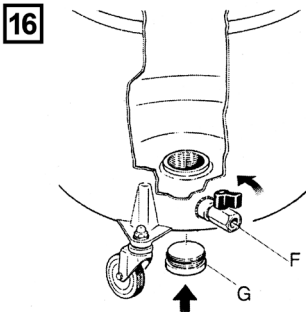

16

## 6. MAINTENANCE

6.1 From time to time clean the grids in the bottom of the tank.

6.2 Waste deposits that accumulate in the bottom of the reservoir can be removed by removing drain plug (G).

## 7. TROUBLESHOOTING

PROBLEM	CAUSE	SOLUTION
Liquid fails to come out of brush	Insufficient liquid in reservoir Insufficient air pressure Lever D in wrong position	Fill Check air connection A, pressure regulator B Turn lever to left position as shown in fig.10.
Dirty fluid comes out of brush	Blocked filters Fluid too old and dirty Contaminated filters	Clean filters Drain off old fluid and replace with clean Clean tank filters

**NOTE:** It is our policy to continually improve products and as such we reserve the right to alter data, specifications and component parts without prior notice.

**IMPORTANT:** No liability is accepted for incorrect use of this product.

**WARRANTY:** Guarantee is 12 months from purchase date, proof of which will be required for any claim.

**INFORMATION:** For a copy of our latest catalogue and promotions call us on 01284 757525 and leave your full name and address, including postcode.



Sole UK Distributor, Sealey Group,  
Kempson Way, Suffolk Business Park,  
Bury St. Edmunds, Suffolk,  
IP32 7AR

01284 757500



www.sealey.co.uk

01284 703534



sales@sealey.co.uk