

Thank you for purchasing a Sealey product. Manufactured to a high standard this product will, if used according to these instructions and properly maintained, give you years of trouble free performance.



IMPORTANT: PLEASE READ THESE INSTRUCTIONS CAREFULLY. NOTE THE SAFE OPERATIONAL REQUIREMENTS, WARNINGS AND CAUTIONS. USE THIS PRODUCT CORRECTLY AND WITH CARE FOR THE PURPOSE FOR WHICH IT IS INTENDED. FAILURE TO DO SO MAY CAUSE DAMAGE AND/OR PERSONAL INJURY AND WILL INVALIDATE THE WARRANTY. PLEASE KEEP INSTRUCTIONS SAFE FOR FUTURE USE.

1. SAFETY INSTRUCTIONS

- WARNING!** Disconnect the gun from the air supply before changing accessories, servicing or performing any maintenance.
- ✓ Maintain the gun in good condition. Replace or repair damaged parts. *Use recommended parts only. Unauthorised parts may be dangerous and will invalidate the warranty.*
- ✓ Keep the gun clean and rinse out nozzle and pipes with paraffin after use.
- WARNING!** If gun components become blocked there is a danger of excessive pressure building up in unit causing the canister to burst.
- ✓ Locate the gun in a suitable, well ventilated area. Keep area clean, tidy and free from unrelated materials and ensure there is adequate lighting.
- ✓ Remove ill fitting clothing. Remove ties, watches, rings and other loose jewellery and contain long hair.
- ✓ Keep children and unauthorised persons away from the working area.
- ✓ Avoid unintentional operation.
- ✓ Ensure underbody coating manufacturer's instructions are carefully followed.
- x DO NOT hold gun or attachments close to your face (especially eyes, ears, etc.) and do not point gun or air hose at other persons or animals.
- x DO NOT carry by the air hose, or yank the hose or the gun from the air supply.
- x DO NOT use the gun for any purpose other than for which it is designed and **do not fill with any other fluid.**
- x DO NOT operate the gun if damaged.
- ✓ When not in use disconnect from the air supply and store in a safe, dry, childproof area.

2. INTRODUCTION & SPECIFICATION

2.1. Introduction

- 2.1.1. The SG139.V2 is used for anti-rust treatment of vehicles and agricultural machines by the application of underbody coating. Fits a standard body schutz canister.
- 2.1.2. Check contents against the following list. If any item is damaged or missing contact your supplier immediately.

- Gun
- Gun Nose
- Suction Tube

2.2. Specification

Air Supply60 - 90psi
 Air Consumption10cfm
 Connection1/4in BSP

3. PREPARING THE GUN FOR USE

3.1 Air Supply

- 3.1.1 Ensure the trigger is not depressed before connecting to the air supply.
- 3.1.2 An air pressure of no more than 90psi and an air volume of 10cfm will be required.
- 3.1.3 **WARNING! Ensure air supply does not exceed 90psi. Too high a pressure will shorten the product life and may be dangerous, causing damage and/or personal injury.**
- 3.1.4 Drain air supply tank daily. Water in the air line will damage the gun and will invalidate your warranty.
- 3.1.5 Clean air inlet filter screen weekly. For recommended hook-up, see figs.1& 2.
- 3.1.6 Line pressure should be increased to compensate for unusually long air hoses (over 8 metres). The minimum hose and fittings diameter should be 10mm I.D.
- 3.1.7 Keep hoses away from heat, oil and sharp edges. Check hoses for wear and make certain that all connections are secure.

3.2. Couplings.

- 3.2.1. Vibration may cause failure if a quick change coupling is connected directly to the wrench. To overcome this, connect a leader hose to the wrench. A quick change coupling may then be used to connect the leader hose to the air line recoil hose. See figs. 1& 2.

Fig 1

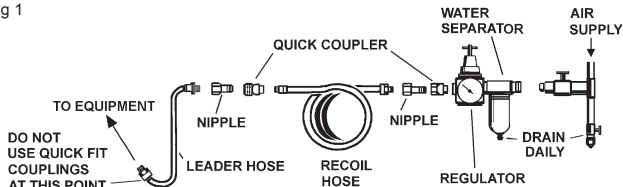

Fig 2



4. OPERATING INSTRUCTIONS

☐ **WARNING!** Ensure you read, understand and apply the safety instructions in Section 1 and follow the manufacturer's instructions on the underbody coating container.

- 4.1. Screw on a canister of schutz underbody coating.
- 4.2. Ensure air supply is regulated to **no more than 6 bar (90psi)** and then attach air hose to the gun.
- 4.3. Aim the nozzle of the gun into a safe area and depress the gun trigger to check for correct operation.

5. MAINTENANCE

☐ **WARNING!** Ensure gun is disconnected from air supply before attempting any maintenance. It is very important to keep the gun and components clean to ensure free passage for the underbody coating.

- 5.1. After use clean all items thoroughly with paraffin and allow to dry before storage.

6. PARTS

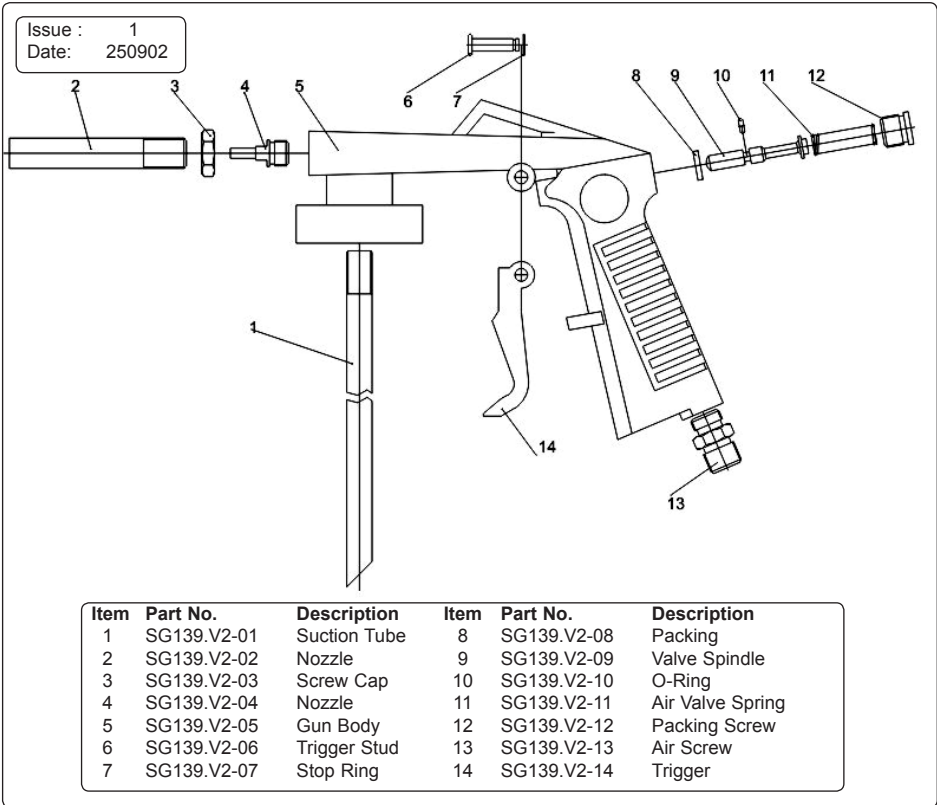

NOTE: It is our policy to continually improve products and as such we reserve the right to alter data, specifications and component parts without prior notice.

IMPORTANT: No liability is accepted for incorrect use of this product.

WARRANTY: Guarantee is 12 months from purchase date, proof of which will be required for any claim.

INFORMATION: For a copy of our latest catalogue and promotions call us on 01284 757525 and leave your full name and address, including postcode.



Sole UK Distributor, Sealey Group,
 Kempson Way, Suffolk Business Park,
 Bury St. Edmunds, Suffolk,
 IP32 7AR

☎ 01284 757500



www.sealey.co.uk



01284 703534



sales@sealey.co.uk