

MODEL No's

SG101.V2

SG115.V2

SG125

SG2303.V2

Thank you for purchasing a Sealey product. Manufactured to a high standard this product will, if used according to these instructions and properly maintained, give you years of trouble free performance.



IMPORTANT: PLEASE READ THESE INSTRUCTIONS CAREFULLY. NOTE THE SAFE OPERATIONAL REQUIREMENTS, WARNINGS AND CAUTIONS. USE THIS PRODUCT CORRECTLY AND WITH CARE FOR THE PURPOSE FOR WHICH IT IS INTENDED. FAILURE TO DO SO MAY CAUSE DAMAGE AND/OR PERSONAL INJURY AND WILL INVALIDATE THE WARRANTY. RETAIN THESE INSTRUCTIONS FOR FUTURE USE.

1. SAFETY INSTRUCTIONS

1.1 ELECTRICAL SAFETY

WARNING! It is the responsibility of the owner and the operator to read, understand and comply with the following:

You must check all electrical products, before use, to ensure that they are safe. You must inspect power cables, plugs, sockets and any other connectors for wear or damage. You must ensure that the risk of electric shock is minimised by the installation of appropriate safety devices. A Residual Current Circuit Breaker (RCCB) should be incorporated in the main distribution board. We also recommend that a Residual Current Device (RCD) is used. It is particularly important to use an RCD with portable products that are plugged into a supply which is not protected by an RCCB. If in any doubt consult a qualified electrician. You may obtain a Residual Current Device by contacting your Sealey dealer. You must also read and understand the following instructions concerning electrical safety.

- 1.1.1 The Electricity at Work Act 1989 requires that all portable electrical appliances, if used on business premises, are tested by a qualified electrician, using a Portable Appliance Tester (PAT), at least once a year.
- 1.1.2 The Health & Safety at Work Act 1974 makes owners of electrical appliances responsible for the safe condition of those appliances and the safety of the appliance operators. If in any doubt about electrical safety, contact a qualified electrician.
- 1.1.3 Ensure that the insulation on all cables and on the appliance is safe before connecting it to the power supply. See 1.1.1 and 1.1.2 and use a Portable Appliance Tester.
- 1.1.4 Ensure that cables are always protected against short circuit and overload.
- 1.1.5 Regularly inspect power supply cables and plugs for wear or damage and check all connections to ensure that none is loose.
- 1.1.6 Important: Ensure that the voltage marked on the appliance matches the power supply to be used and that the plug is fitted with the correct fuse - see fuse rating at right.
- 1.1.7 DO NOT pull or carry the appliance by the power cable.
- 1.1.8 DO NOT pull the plug from the socket by the cable.
- 1.1.9 DO NOT use worn or damaged cables, plugs or connectors. Immediately have any faulty item repaired or replaced by a qualified electrician. When a BS 1363/A UK 3 pin plug is damaged, cut the cable just above the plug and dispose of the plug safely. Fit a new plug according to the following instructions (UK only).
 - a) Connect the GREEN/YELLOW earth wire to the earth terminal 'E'.
 - b) Connect the BROWN live wire to the live terminal 'L'.
 - c) Connect the BLUE neutral wire to the neutral terminal 'N'.
 - d) After wiring, check that there are no bare wires, that all wires have been correctly connected, that the cable outer insulation extends beyond the cable restraint and that the restraint is tight. Double insulated products, which are always marked with this symbol , are fitted with live (brown) and neutral (blue) wires only. To rewire, connect the wires as indicated above - DO NOT connect either wire to the earth terminal.
- 1.1.10 Products which require more than 13 amps are supplied without a plug. In this case you must contact a qualified electrician to ensure that a suitably rated supply is available. We recommend that you discuss the installation of an industrial round pin plug and socket with your electrician.
- 1.1.11 If an extension reel is used it should be fully unwound before connection. A reel with an RCD fitted is preferred since any appliance plugged into it will be protected. The cable core section is important and should be at least 1.5mm², but to be absolutely sure that the capacity of the reel is suitable for this product and for others which may be used in the other output sockets, we recommend the use of 2.5mm² section cable.

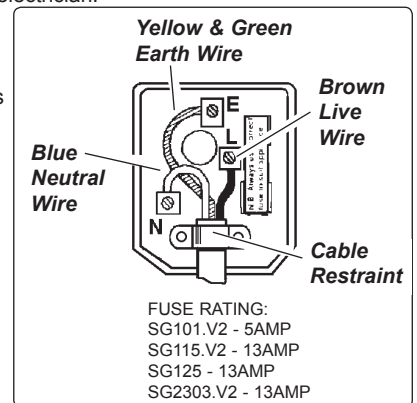

1.2. GENERAL SAFETY

- ✓ Disconnect the grinder from the mains power before changing accessories, servicing or performing any maintenance.
- ✓ Maintain grinder and discs in good condition. Check moving parts and alignment. If necessary use an authorised service agent.
- ✓ Replace or repair damaged parts. *Use recommended parts only. Unauthorised parts may be dangerous and will invalidate the warranty.*
- ✓ Keep the grinder clean for best and safest performance.
- ❑ **WARNING!** Always work with the grinder safety guard in place.
- ✓ Wear approved safety goggles, ear defenders, appropriate dust mask if grinder generates dust and safety gloves.
- ✓ Remove ill fitting clothing. Remove ties, watches, rings and other loose jewellery and contain long hair.
- ✓ Use grinder in a suitable work area. Keep area clean, tidy and free from unrelated materials and ensure that there is adequate lighting.
- ✓ Maintain correct balance and footing. DO NOT over-reach and ensure that the floor is not slippery. Wear non-slip shoes.
- ✓ Use only approved grinding discs and only use the normal grinding surface. Never use the side or upper surface of disc for cutting.
- ✓ The grinding disc may only be changed by a person holding a grinding wheel certificate.
- ✓ Check grinding disc to ensure it is not split, cracked or damaged in anyway (See Section 4). If in doubt do not use the disc.
- ✓ Grinding discs must be securely attached before use, but not overtightened.
- ✓ Secure unstable workpiece with a clamp, vice or other adequate holding device and ensure that the grinder is gripped with both hands.
- ✓ Keep children and unauthorised persons away from the work area.
- x DO NOT operate the grinder if any parts are missing or damaged.
- x DO NOT use the grinder for a task it is not designed to perform.
- x DO NOT operate the grinder where there are flammable liquids or gases.
- ❑ **WARNING! DO NOT** grind or sand materials containing asbestos.
- x DO NOT get the grinder wet or use in damp or wet locations.
- x DO NOT switch the grinder on whilst the disc is in contact with the workpiece.
- x DO NOT cover the grinder air vents. To do so will overheat the machine.
- x DO NOT touch the workpiece immediately after grinding as it will be very hot.

- x **DO NOT** use the grinder as a fixed tool, and **DO NOT** try to cool the grinding discs with water or other lubricants.
- x **DO NOT** hold unsecured work in your hand and **DO NOT** touch the grinding disc whilst operating, or whilst plugged into the mains power.
- x **DO NOT** leave the grinder running unattended and **DO NOT** lay the grinder down whilst it is running.
- x **DO NOT** operate the grinder when you are tired or under the influence of alcohol, drugs or intoxicating medication.
- ✓ When not in use, switch off grinder, remove plug from power supply and store in safe, dry, childproof area.

DANGER OF FIRE/EXPLOSION HAZARD

- ☐ **WARNING!** The grinding process can produce streams of sparks (especially when grinding metal) which are a potential source of ignition.
- x **DO NOT** use the grinder where there are flammable liquids, solids or gases.
- x **DO NOT** allow grinder sparks to make contact with the operator's clothing or any other fabric such as cleaning rags. Fabrics contaminated with inflammable materials such as petrol, oil, grease, paint and solvents are a particular fire hazard.
- ✓ To reduce the risk of clothing catching fire the operator should wear wool or cotton outer garments treated with a fire retardant in preference to man-made fibres.

Risk of Hand Arm Vibration Injury

Angle Grinder Model No. SG101.V2, SG115.V2, SG125 & SG2303.V2 when operated in accordance with these instructions and tested in accordance with EN 28662-2: 1994 results in the following vibration emission declared in accordance with BS EN12096: 1996.

SG101.V2, SG115.V2

Measured vibration emission value: . . . 1.7m/s²
 Uncertainty: 0.9m/s²

SG125

Measured vibration emission value: . . . 2.52m/s².
 Uncertainty: 0.7m/s².

SG2303.V2

Measured vibration emission value: . . . 2.63m/s²
 Uncertainty: 0.7m/s²

These values are suitable for comparison with emission levels of other tools that have been subject to the same test.

This tool may cause hand-arm vibration syndrome if its use is inadequately managed.

This is a 'NO LOAD' vibration figure.

A competent person should carry out a risk assessment following HSE guidelines. Measurement results can be highly variable, depending on many factors, including the operator's technique, the condition of the work equipment, the material being processed and the measurement method.

Recommended Measures to reduce risk of hand-arm vibration syndrome:

We recommend appropriate safety equipment is utilised and regular breaks for the operator are employed to reduce any residual risk of fatigue or repetitive strain injury.

2. CONTENTS & SPECIFICATION

Remove items from packing and identify parts against fig.1. If any part is damaged or missing contact your supplier immediately.

CONTENTS

1. Main unit.
2. Safety guard.
3. Handle.
4. Pin wrench.
5. Clamping flange.
6. Flange nut.

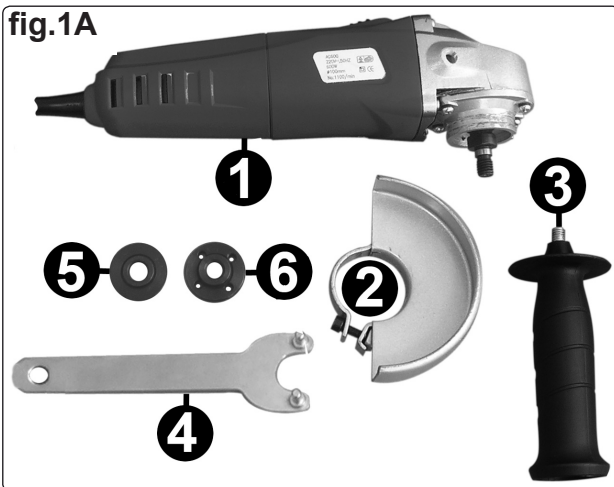

SG101.V2

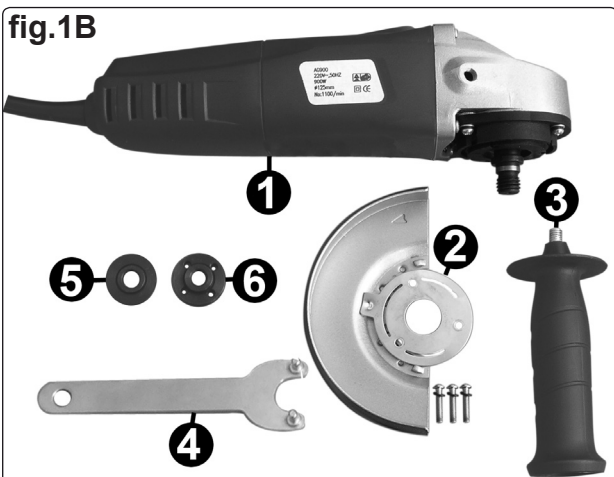

SG115.V2

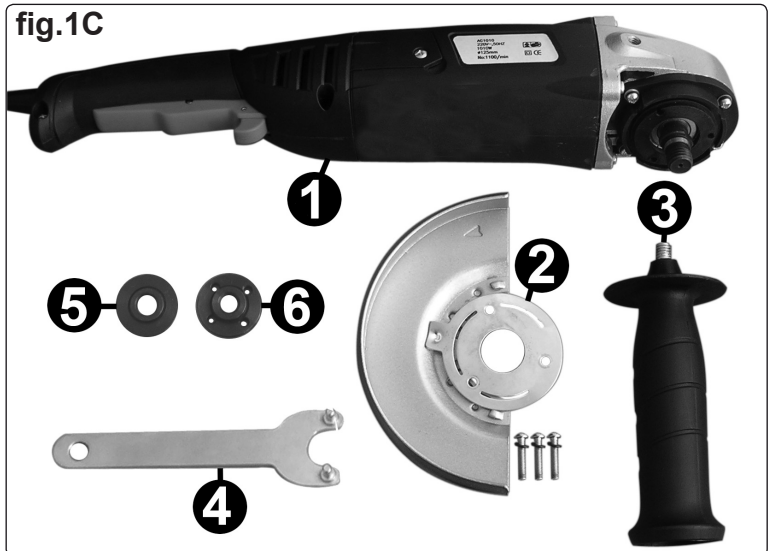

SG125

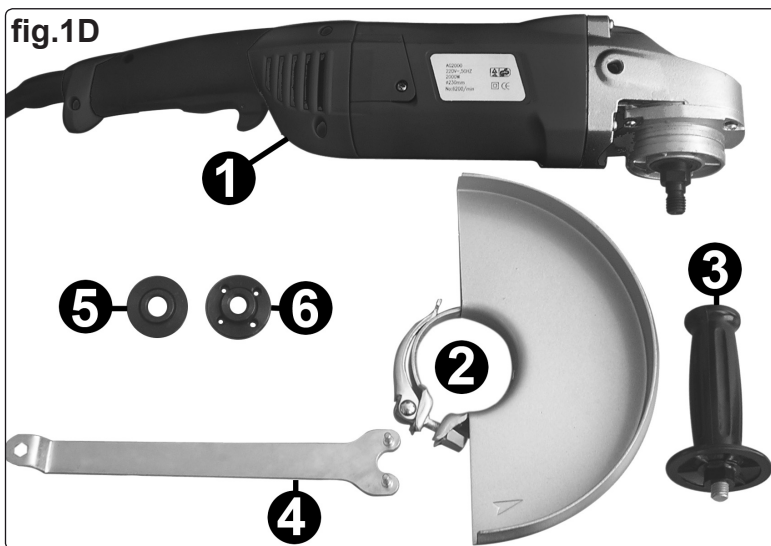

SG2303.V2

SPECIFICATION - SG101.V2

Power input 600 watt
No-load speed 11,000rpm
Spindle size M10

Grinding/Cutting disc max. diam 100mm
Sound pressure level 85.1dB(A)

Sound power level 96.19dB(A)
Weight 1.8kg

SPECIFICATION - SG115.V2

Power input 900 watt
No-load speed 11,000rpm
Spindle size M14

Grinding/Cutting disc max. diam 115mm
Sound pressure level 86.3dB(A)

Sound power level 99.3dB(A)
Weight 2.2kg

SPECIFICATION - SG125

Power input 1000 watt
No-load speed 11,000rpm
Spindle size M14

Grinding/Cutting disc max. diam 125mm
Sound pressure level 89.4dB(A)

Sound power level 102.4dB(A)
Weight 2.4kg

SPECIFICATION - SG2303.V2

Power input 2000 watt
No-load speed 6,000rpm
Spindle size M14

Grinding/Cutting disc max. diam 230mm
Sound pressure level 91.2dB(A)

Sound power level 104.2dB(A)
Weight 5.5kg

3. ASSEMBLY & ADJUSTMENT

☐ **WARNING!** Ensure that the grinder is unplugged from the power supply before assembly.

3.1. Fitting the Guard Assembly. (SG101.V2)

- 3.1.1 The guard may be orientated at any angle to suit the grinding task required and should be positioned to allow maximum working performance whilst providing maximum personal protection for the operator.
3.1.2 Loosen locking screw and turn the guard to the required position. Lock the guard in place by re-tightening the locking screw.

3.2. Fitting the Guard Assembly. (SG115.V2, SG125)

- 3.2.1 The guard may be orientated at any angle to suit the grinding task required and should be positioned to allow maximum working performance whilst providing maximum personal protection for the operator.
3.2.2 Take the guard and place it around the spindle as in fig.4, place the securing plate (fig.4B) around the spindle and line up the holes in the plate with the holes in the main unit as in fig.4 and secure with screws (fig.4A).

3.3. Fitting the Guard Assembly. (SG2303.V2)

- 3.3.1 The guard may be orientated at any angle to suit the grinding task required and should be positioned to allow maximum working performance whilst providing maximum personal protection for the operator.
3.3.2 Take the guard (fig.1 item 2) and unlock the clamp. On the inside of the guard clamping collar is a small pip (indicated by arrow 'A' in fig.5) which must be aligned with a notch in the housing (also indicated by arrow 'A'). Orientate the guard as shown in fig.5 and place it over the central spindle and onto the housing. Leaving the clamp open, rotate the guard on the housing until it is over the main body of the tool as indicated in fig.3.
3.3.3 Lock the guard in place by pushing the clamp lever towards the centre spindle as shown in fig.3.

3.4. Attaching a Grinding/Cutting Disc.

(Discs should only be fitted by a person holding a grinding wheel certificate).

- 3.4.1 Lay the grinder on its back and place the clamping flange onto the centre spindle with the raised ring facing upwards (see fig.2 item 5). Rotate the clamping flange on the spindle until the flats on its back face drop into alignment with the flats on the spindle. When the clamping flange is in the correct position it can no longer be rotated on the spindle.
3.4.2 Place the grinding (or cutting) disc over the spindle and onto the clamping flange.
Figures A, B & C show the correct orientation of the disc retaining flange nut for the different types of disc. (SEE OVER)
3.4.3 When using a grinding disc with a depressed centre portion as in fig.A, screw the disc retaining flange nut onto the spindle with the raised ring facing downwards.
3.4.4 When using flat cutting discs as in fig.C and cutting discs with a depressed centre portion as in fig.B, screw the disc retaining flange nut onto the spindle with the raised ring facing upwards.
3.4.5 Stop the spindle from turning by pushing in and holding the disc stop button (see fig.2.7).
3.4.6 Lock the grinding disc into place by tightening the disc retaining flange nut with the pin wrench (fig.2 item 4).
3.4.7 When complete, release the locking button and check that it has sprung back to its initial position.

3.5. Fitting the Hand Grip.

Always use the hand grip for better control and improved safety. Fit the hand grip (fig.1.3) by screwing it into the appropriate left, right or top position on the grinder head as indicated in fig.2.

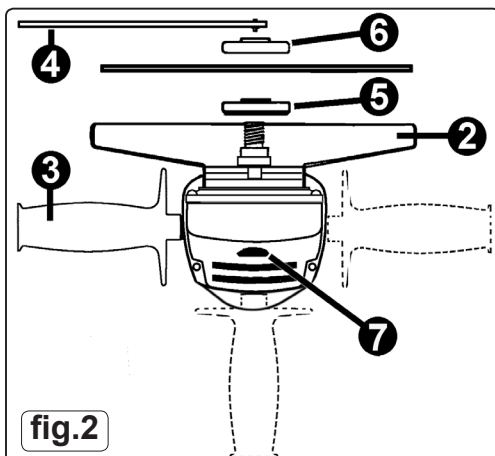

Original Language Version

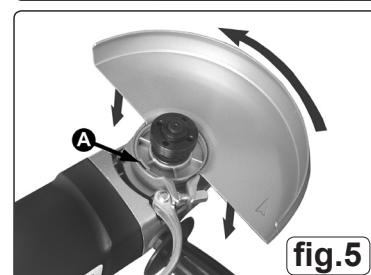
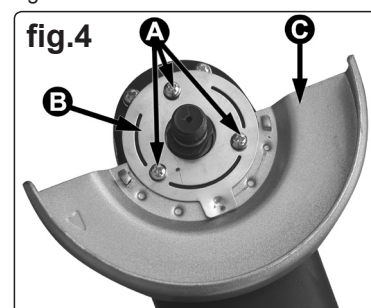

4. GRINDING/CUTTING DISCS

❑ **WARNING! DO NOT USE DISCS THAT ARE DAMAGED, OR SUSPECTED TO BE DAMAGED.**

4.1 Before using a grinding/cutting disc ensure that there are no fissures or cracks. Once mounted on the grinder, test the disc before use by facing the grinder in a safe direction (point away from yourself, others and vulnerable items) and run for a short time.

▲ **DANGER! Use of damaged discs is dangerous and may cause personal injury.**

4.2 Grinding and cutting discs used in association with this machine shall be of an adequate speed rating and be suitable for the job in hand. The discs shall be made in accordance with British Standard 4481:Part 1 1989. Only persons holding a grinding wheel certificate are authorised to change grinding discs. Ensure that the speed rating on the disc is equal to, or higher than, that of the grinder.

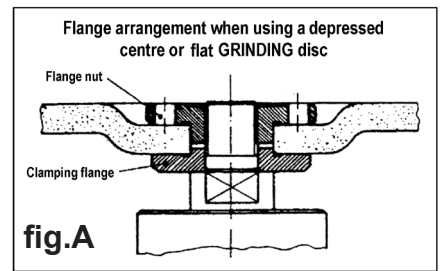

5. OPERATING INSTRUCTIONS

❑ **WARNING! Ensure grinder is unplugged from the mains power supply before changing accessories.**

5.1 PREPARATION

5.1.1 Attach grinding/cutting disc according to section 3.2. and position the handle grip conveniently for the task.

5.1.2 Ensure the disc safety guard is correctly positioned.

5.1.3 Plug grinder into the mains power supply.

❑ **WARNING! When the grinder first starts it will kick to the right. You must ensure, therefore, that the tool is securely gripped in both hands. Especially important is the position you choose for the side handle in order to maintain stability.**

❑ **WARNING! Before use, ensure that you are wearing approved safety goggles, ear defenders, appropriate dust mask if dust will be generated and safety gloves, and that all other safety instructions in Section 1 are followed carefully.**

5.2 ON/OFF Switch (SG101.V2, SG115.V2)

5.2.1 The On/Off switch (fig 6A) is designed to avoid accidental starting.

5.2.2 Once plugged into the power supply start the grinder by sliding the switch forward and pressing down.

5.2.3 To turn off the machine press the switch at the rear and it will spring back to the 'Off' position.

5.3 ON/OFF Switch (SG125, SG2303.V2)

5.3.1 Once plugged into the mains power supply the grinder is started by a two stage switching operation. Place your fingers over the switch and using your index finger unlock the trigger by pushing the lock lever forwards and then squeeze the trigger into the 'ON' position. (See fig.7)

5.3.2 To stop the grinder release the trigger.

5.3.3 When the trigger is released and returns to the 'OFF' position it is automatically locked to prevent inadvertent starting.

5.3.4 The trigger can be locked in the 'ON' position for continuous running. To do this release the lock and squeeze the trigger as previously described. With the trigger fully depressed push the lock lever one stage further forward. Whilst maintaining pressure on the lock lever release the trigger which will now stay in the 'ON' position.

5.3.5 To stop the grinder squeeze the trigger to unlock it and release the trigger.

5.3.6 If the power is cut to the grinder whilst the switch is locked 'ON' always release the trigger and unplug the grinder. Do not reconnect the grinder until you are sure that the power has been restored.

5.4 GRINDING

5.4.1 The key to effective operating is controlling the pressure and surface contact between the disc and the workpiece.

❑ **WARNING! DO NOT switch the grinder on whilst the disc is in contact with the work piece. Bring the rotating disc to the workpiece.**

5.4.2 Allow the disc to reach full speed before starting to grind.

5.4.3 Grind flat surfaces at an angle of between 10 to 20 degrees to the work piece. Too great an angle will cause a concentration of pressure in one small area resulting in gouging or burning of the surface.

5.4.4 When grinding is complete allow the workpiece to cool. DO NOT touch the hot surface.

5.4.5 Unplug the grinder from the mains power supply, clean and store in a safe, dry, childproof area.

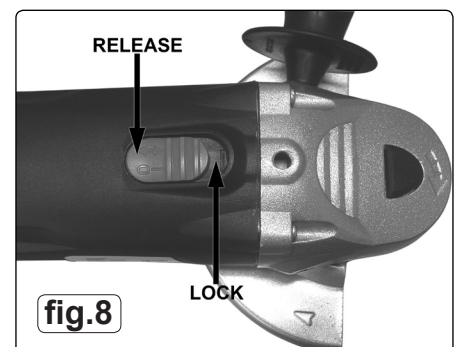
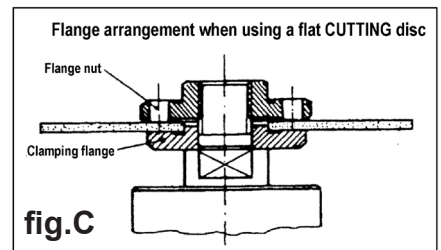
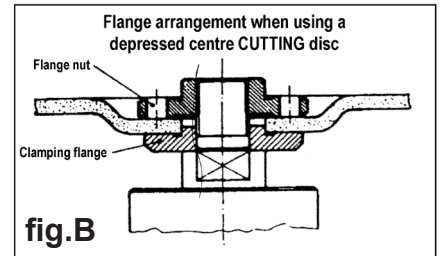

6. MAINTENANCE

⚠ **WARNING!** Ensure that the grinder is disconnected from the mains power supply before attempting any maintenance.

6.1 Cleaning

- 6.1.1 Keep the grinder ventilation slots clean and free from obstructions. If available, blow compressed air into the vents to clear any internal dust (safety goggles must be worn when undertaking this process). Keep the outer case of the grinder clean and free from grease. DO NOT wash with water or use solvents or abrasives.

6.2 Changing the motor brushes (SG101.V2, SG115.V2)

- 6.2.1 Remove the screw at the rear of the grinder then pull the rear body casing away.
6.2.2 Release the brush assembly cap as in fig.9.
6.2.3 Remove the brush assembly and replace.
6.2.4 Refitting is a reversal of the above procedure.
6.2.5 Repeat for the second brush on the other side of the grinder.

6.3 Changing the motor brushes (SG125, SG2303.V2)

- 6.3.1 Remove the screw from the side panel half way up the grinder, then remove panel
6.3.2 Release the tension spring from the carbon brush and slide it out of the brush holder. (fig.10)
6.3.3 Replace the motor brush.
6.3.4 Refitting is a reversal of the above procedure.
6.3.5 Repeat for the second brush on the other side of the grinder.

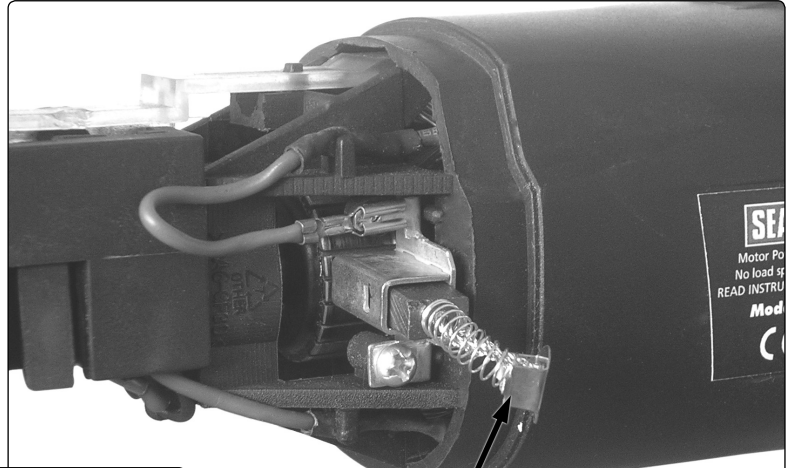

Release the brush assembly cap and pull out the motor brush

fig.9

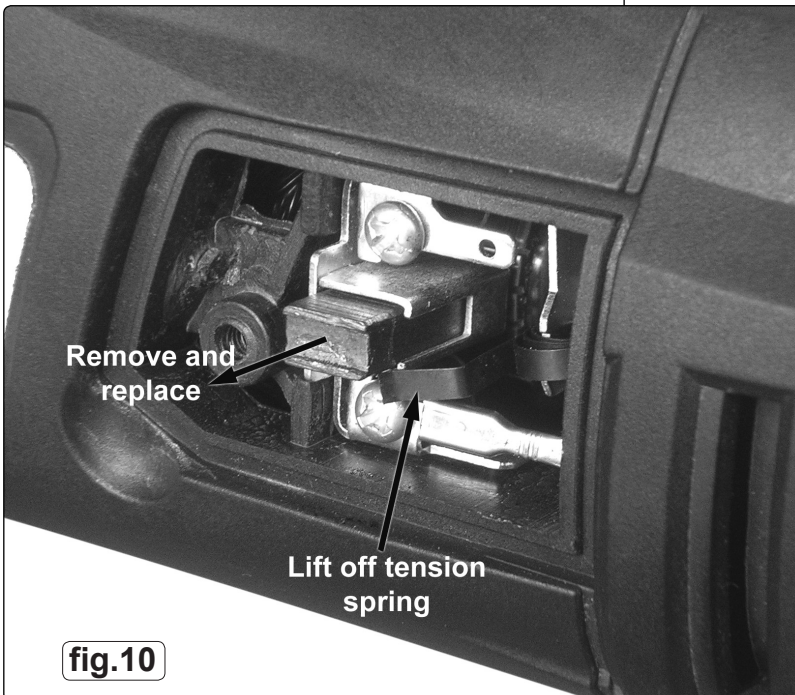

Remove and replace

Lift off tension spring

fig.10

NOTE: It is our policy to continually improve products and as such we reserve the right to alter data, specifications and component parts without prior notice.

IMPORTANT: No liability is accepted for incorrect use of this product.

WARRANTY: Guarantee is 12 months from purchase date, proof of which will be required for any claim.

INFORMATION: For a copy of our latest catalogue and promotions call us on 01284 757525 and leave your full name and address, including postcode.



Sole UK Distributor, Sealey Group,
Kempson Way, Suffolk Business Park,
Bury St. Edmunds, Suffolk,
IP32 7AR

01284 757500

www.sealey.co.uk

01284 703534

sales@sealey.co.uk