

Thank you for purchasing a Sealey product. Manufactured to a high standard this product will, if used according to these instructions and properly maintained, give you years of trouble free performance.



**IMPORTANT: PLEASE READ THESE INSTRUCTIONS CAREFULLY. NOTE THE SAFE OPERATIONAL REQUIREMENTS, WARNINGS & CAUTIONS. USE THE PRODUCT CORRECTLY AND WITH CARE FOR THE PURPOSE FOR WHICH IT IS INTENDED. FAILURE TO DO SO MAY CAUSE DAMAGE OR PERSONAL INJURY, AND WILL INVALIDATE THE WARRANTY. PLEASE KEEP INSTRUCTIONS SAFE FOR FUTURE USE.**

### 1. SAFETY INSTRUCTIONS

#### 1.1 ELECTRICAL SAFETY.

**ONLY USE THE SUPPLIED TRANSFORMER PLUG FOR CONNECTING UNIT TO THE MAIN ELECTRICAL POWER SUPPLY.**

**WARNING!** It is the user's responsibility to read, understand and comply with the following electrical instructions:

You must ensure the risk of electric shock is minimised by the installation of appropriate safety devices. An RCCB (Residual Current Circuit Breaker) should be incorporated in the main distribution board. We also recommend that an RCD (Residual Current Device) is used with all electrical products, particularly portable equipment which is plugged into an electrical supply not protected by an RCCB.

**You must** also read and understand the following instructions concerning electrical safety.

**1.1.1 The Electricity At Work Act 1989** requires all portable electrical appliances, if used on business premises, to be tested by a qualified electrician, using a Portable Appliance Tester (PAT), at least once a year.

**1.1.2 The Health & Safety at Work Act 1974** makes owners of electrical appliances responsible for the safe condition of the appliance, and the safety of the appliance operator. **If in any doubt about electrical safety, contact a qualified electrician.**

**1.1.3 You must ensure that you:**

- ✓ Inspect the transformer plug, cable, adaptor for wear and damage to ensure items are safe before connecting to the mains power supply. If worn or damaged DO NOT use, immediately replace, or contact a qualified electrician.
- ✓ Check cables are always protected against short circuit and overload.
- ✓ Important: Check that the voltage marked on the transformer plug is the same as the power supply to be used.
- ✓ Uncoil the power cable between the transformer and the powered product.
- x **DO NOT** pull transformer power lead, or pull the transformer plug from the mains socket by the power lead.
- x **DO NOT** use any other type of transformer with this product.
- x **DO NOT** place the power connector into any area of the product except the correct inlet socket.
- x **DO NOT** try to open or dis-assemble the transformer plug.
- x **DO NOT** use the transformer plug to power any other electrical item.
- x **DO NOT** get the transformer wet, or use in wet, damp conditions (for indoor use only).
- WARNING!** NEVER substitute a standard 13Amp 3 pin plug, or any other type of plug, for the transformer plug.

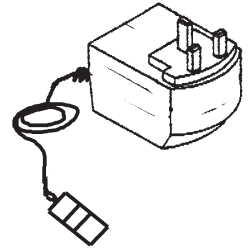

**Cable extension reels.** When a cable extension reel is used it should be fully unwound before connection. A cable reel with an RCD fitted is recommended since any product which is plugged into the cable reel will be protected. The section of the cable on the cable reel is important. We recommend that at least 1.5mm<sup>2</sup> section cable but to be absolutely sure that the capacity of the cable reel is suitable for this product and for others that may be used in the other output sockets, we recommend the use of 2.5mm<sup>2</sup> section cable.

#### 1.2 GENERAL SAFETY

- WARNING!** Ensure Health & Safety, government and local authority regulations relating to shot blasting are adhered to when using this equipment. Familiarise yourself with the application, limitations, and potential hazards peculiar to the cabinet.
- WARNING!** Disconnect cabinet from mains power and air supply before changing accessories, servicing or performing any maintenance.
- ✓ Maintain the cabinet in good condition Replace or repair damaged parts. *Use genuine parts only. Unauthorised parts may be dangerous and will invalidate the warranty.*
- ✓ Locate cabinet in a suitable working area. Keep area clean, tidy and free from unrelated materials. Ensure adequate lighting.
- ✓ **IMPORTANT: Use only dry abrasives such as glass bead, silica sand, aluminium oxide and other proprietary brands of blasting media. We recommend Sealey item B5KG. Never use fluids or mix fluids with another media in unit.**
- WARNING!** Always wear approved eye/face protection and ear protection when operating the cabinet.
- ✓ Remove ill fitting clothing. Remove ties, watches, rings, and other loose jewellery, and contain and/or tie back long hair.
- ✓ Keep the side door closed and secured when in use.
- WARNING!** Ensure correct air pressure is maintained and not exceeded. Always keep blast nozzle directed at the workpiece. DO NOT aim blast at gloves, glove fingers or internal light. Never use outside the unit. Regularly check that the exhaust vent at the back of the cabinet is clear and not blocked and there is space between it and any wall.
- ✓ Maintain correct balance and footing. Ensure the floor is clean and free from blasting grit spillage. Wear non-slip shoes.
- ✓ Keep children and non essential persons away from the working area.
- x **DO NOT** use the cabinet for a task it is not designed to perform.
- x **DO NOT** operate the cabinet if any parts are damaged or missing as this may cause failure and/or possible personal injury.
- x **DO NOT** operate the cabinet with the side door open.
- x **DO NOT** use the gun without appropriate nozzle fitted.
- x **DO NOT** stand on the cabinet.
- x **DO NOT** get the cabinet wet or use in damp or wet locations or areas where there is condensation.
- x **DO NOT** operate the cabinet when you are tired or under the influence of alcohol, drugs or intoxicating medication.
- x **DO NOT** leave the cabinet operating unattended.
- ✓ The viewing screen is 5mm tempered glass. If glass should break ensure you replace with tempered or safety glass only.
- ✓ When not in use disconnect from the electrical mains and the air power supply.

**NOTE! We strongly recommend that a suitable dust extraction system is used with this unit.**

### 2. DESCRIPTION & SPECIFICATION

Heavy-duty steel cabinet with toughened glass viewing screen and integral low voltage illumination. Large single side door provides easy access for bulkier items. Includes Ø60mm dust extraction port for a clear view. Heavy gauntlets provide hand protection and each cabinet is supplied with sand blasting gun, four sizes of ceramic nozzle and a pack of five visor covers. Suitable for glass beads, silica sand, aluminium oxide and other proprietary brands of blasting media.

Capacity ..... 0.22m<sup>3</sup>  
 Maximum air flow ..... 15cfm  
 Air Pressure ..... 60-90psi  
 Air inlet size ..... 1/4" BSP  
 Overall height ..... 1380mm  
 Overall width ..... 890mm

Depth ..... 570mm  
 Doors ..... 1  
 Extraction Port Ø ..... 60mm  
 Viewing Area ..... 570 x 270mm

### 3. ASSEMBLY & INSTALLATION

- 3.1 Assembly.** (This cabinet should be assembled by two people).
- 3.1.1 Unpack the product and check contents. Should there be any damaged or missing parts contact your supplier immediately.
  - 3.1.2 Protect the cabinet (fig.1-3) from scratches and lay it on its side.
  - 3.1.3 Push trim moulding (1) onto the bottom of each leg (2).
  - 3.1.4 Attach the four legs (2) to cabinet (3) by passing screws from outside and finger tighten with nuts on the inside of the cabinet.
  - 3.1.5 Carefully peel backing paper from the foam sealing strip and lay the exposed sticky surface all around the upper rim of funnel (fig.1-T1). Trim as required ensuring there are no gaps. Make holes in foam where screws are to go.
  - 3.1.6 Also apply a layer of foam sealing tape all around the underside edge of the main cabinet. See fig.1-T2.
  - 3.1.7 Also apply tape to the sealing surfaces of the door if not already applied.
  - 3.1.8 Bolt the suction tube (7) to the inside of the front surface of the funnel (5).
  - 3.1.9 Place the screen frame (12) on top of the funnel ensuring that the mounting holes line up.
  - 3.1.10 Sit the wire mesh shelf (4) into the recess in the screen frame.
  - 3.1.11 Carefully move this assembly up against the underside of the cabinet ensuring that the funnel outlet locking lever (A) is facing to the front.
  - 3.1.12 Ensure the sealing strips are intact, and fix cabinet and funnel with screws, and nuts. The screws should be on the inside of the cabinet.
  - 3.1.13 Position shelf (6) so that the funnel passes through the centre hole, and align shelf with securing holes in the middle of each leg and fix with screws and nuts.
  - 3.1.14 Carefully stand the cabinet upright. Check that the cabinet is level, then tighten all fixings.
  - 3.1.15 The air input fittings should be mounted through the hole in the bottom right hand corner of the cabinet front. Slide the metal washer followed by the rubber washer over the air hose fitting (15) and insert it through the hole in the cabinet from the inside. Place another metal washer over the protruding threads and screw on the air input fitting (14). Tighten the fitting to ensure a good seal.
  - 3.1.16 Attach the larger diameter hose (10) to the gun adjacent to the nozzle and secure it with the worm drive clip supplied. Slide another worm drive clip over the hose and push the free end of the hose onto the suction pipe inside the cabinet and tighten the clip.
  - 3.1.17 Attach the smaller diameter hose to the gun handle and secure it with a worm drive clip. Slide another clip over the hose and push the free end of the hose onto the air hose fitting on the inside of the cabinet. Tighten the clip.

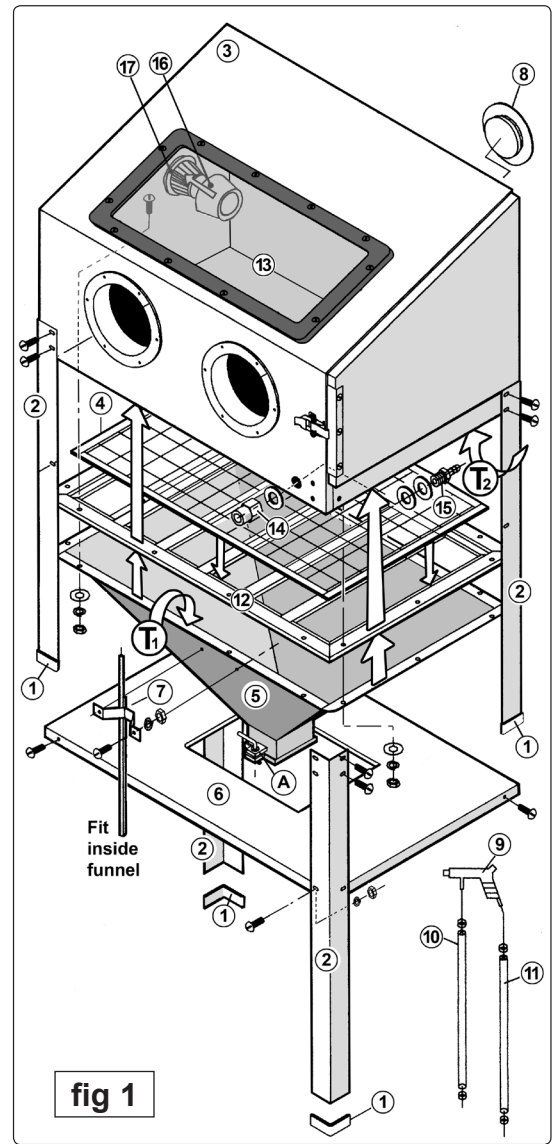

- 3.2 Air Supply.** For recommended hook-up, see diagram to below.
- 3.2.1 You will require an air pressure of 90psi, and an air volume of 15cfm max for operating the unit.  
 **WARNING! Ensure air supply does not exceed 90psi. Too high an air pressure and unclean air will shorten the product life due to excessive wear, and may be dangerous causing possible damage and/or personal injury.**

3.2.2 The air supply must be clean and dry. Drain the air supply tank daily. Water in the air line will damage the item being blasted and will invalidate the warranty.

- 3.2.3 Clean the air inlet filter screen weekly.
- 3.2.4 Line pressure should be increased to compensate for unusually long air hoses (over 8 metres). The **minimum** hose diameter should be 10mm I.D. and fittings must have the same inside dimensions.
- 3.2.5 Keep hose away from heat, oil and sharp edges. Check hoses for wear. Make certain all connections are secure.

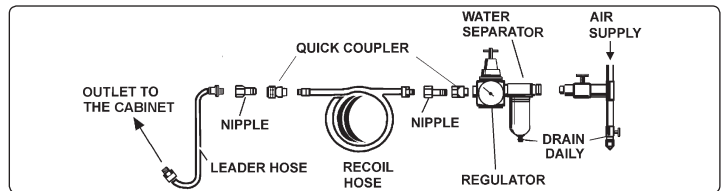

- 3.2.6 Use an appropriate coupling suitable for your air system to connect the air supply to the 1/4" air inlet fitting on the cabinet.
- 3.2.7 Ensure the air gun (fig.1-9) trigger is off before connecting to the air supply.
- 3.2.8 Check all fitting to ensure there are no leaks, and check that the media supply hose is tightly attached to the underside of the gun.

**3.3 Shot Blast Media.**

- 3.3.1 Open the side door and pour the abrasive media into the centre of the cabinet funnel until it is **half full**. DO NOT over fill, as excessive amounts of media will impair visibility, create poor blasting performance and could block the air exhaust at the rear of the cabinet.
- 3.3.2 Plug the transformer cable into the electrical inlet on the left hand side of the blast cabinet at the top.

**3.4 Dust extraction:** If not using an extraction system, remove the cover from air flow outlet (Fig.1-8) at rear right hand side of the cabinet to allow air flow.

- 3.4.1 **We strongly recommend that a suitable dust extraction system is used with this unit.**  
 The blast cabinet should be connected to a dust extraction unit. To do so, remove the plastic sealing plate (Fig.1-8) from the rear of the cabinet and use the same screws to attach the plastic dust outlet. Fit a filter over the dust outlet to ensure that no abrasive is taken into the extraction unit. Finally, connect the outlet to the extraction unit and use in accordance with the extractor instructions.

### 4. OPERATING INSTRUCTIONS

- WARNING! Ensure you read, understand and apply safety instructions in Section 1 before using the unit.**
- 4.1 The unit is supplied with four ceramic nozzles being 4, 5, 6, & 7mm hole diameter respectively. The choice of nozzle depends on the size of the blasting media. Coarse media should be used with the larger nozzles, fine media should be used with the smaller

nozzles. To fit a new nozzle, unscrew the nozzle retaining ring, remove the existing nozzle and replace with the new one. Place the workpiece in the centre of the cabinet and ensure you close and latch side door.

- ☐ **WARNING! Failure to securely close the door could result in damage and/or personal injury.**
- 4.2 Connect the transformer plug to the mains power supply and switch the internal cabinet light on. Turn the air supply on, (having first adjusted to 90psi). If attached, start the dust extraction unit. If no extraction unit is available, remove the air flow cover from rear (Fig.1-8).
- 4.3 Insert your hands into the rubber gloves inside the cabinet making sure that your fingers are correctly positioned and check that you are able to easily move your hands and grasp objects correctly.
- 4.4 Grasp the gun with one hand and point the nozzle at the bottom of the cabinet. Depress the trigger to start the blasting process and check to ensure everything is working correctly. If there are any leaks, stop and fix before use. If no flow is achieved, momentarily cover the gun nozzle in order to force the compressed air back through the grit hose to clear any lodged media.
- 4.5 Hold the workpiece with the other glove. Hold and move the workpiece to ensure you keep glove and fingers out of the nozzle blast stream. DO NOT aim the blast at your fingers, gloves or internal light.
- 4.6 Aim the nozzle directly at the surface of the workpiece and move the blast media (which looks like steam) continuously over the workpiece in an even and circular motion. To avoid undesirable peening, the flow should not be too hard or concentrated. The work finish may vary from coarse to fine depending on the size of the abrasive media. On delicate workpieces, to avoid unnecessary peening or excessive abrasion, begin the blasting with a reduced airflow.
- 4.7 To open the cabinet to check progress or to access content, release the trigger and lay the gun on the mesh shelf. Remove your gun hand first, and then your other hand. Only then is it safe to open the side door.
- 4.8 When work is complete, disconnect gun from the air line, unplug from the mains electrical supply and switch off dust extraction.

## 5. MAINTENANCE

- ☐ **WARNING! Ensure the cabinet is disconnected from the electrical and air supplies before attempting any maintenance.**
- 5.1 Keep the blast cabinet clean and dry. Do not use abrasives to clean the unit.
- 5.2 Ensure the blasting media does not become damp. Keep the air supply dry at all times. Dispose of any damp media.
- 5.3 Replace media when it has become excessively dusty, loses its granular or spherical appearance, or debris from workpieces mixes in with it. This is usually noticed when media from the nozzle looks like a smoke cloud rather than steam.
- 5.4 To change media, place an appropriate container under funnel outlet and turn the locking lever to open. Wear a dust mask to perform this task.
- 5.5 If used, regularly check that the exhaust vent at the back of the cabinet (fig.1-8) is clear and not blocked. If you use an extraction unit change the filters according to use.
- 5.6 Regularly check gun blast nozzle to ensure it does not become blocked with media. Immediately replace worn or damaged nozzles.
- 5.7 If abrasive pick-up hose becomes blocked, re-power the unit and ensure the door is correctly closed. Cover the gun tip and force air back through the hose to clear any media.
- 5.8 The transparent screen has a replaceable covering on the underside of the lid. If visibility is reduced, replace the protective cover.
- 5.9 Check that the gloves are in good condition. If damaged replace immediately.
- 5.10 To replace internal cabinet light.  
Undo the nut and bolt on each end clamp. Push the light towards the cabinet side until it is out of the nearest clamp. Angle the light downwards and pull it towards you to release it from the far clamp. Remove each plastic end (these are a tight fit) and slide the light assembly out of the clear tube. Disconnect the electrical terminals and gently slip the rubber retaining rings from the tube releasing it from the back reflector. Slip the rubber retaining rings onto the new tube and connect the terminals at either end. Bring the reflector up behind the tube and slide the assembly back into the clear tube. Refit the end caps and slide the assembly into the clear tube. Replace end caps and remount in the cabinet.

## 6. TROUBLESHOOTING

PROBLEM	POSSIBLE CAUSE	REMEDY
Excessive dust in the cabinet.	1. Exhaust vent or air flow is blocked. 2. Abrasive is worn. 3. Too much abrasive in the cabinet 4. Loose air line or fittings.	1. Clean vent and keep vent away from any wall. Connect to a suitable dust extraction system. 2. Replace. 3. Remove excess. 4. Check and tighten all air fittings.
Uneven blasting.	1. Too much abrasive in cabinet. 2. Moisture inside cabinet.	1. Remove excess. 2. Check air line for moisture.
Inadequate speed or efficiency of blast.	1. Abrasive is worn. 2. Pressure is too low.	1. Replace. 2. Check that there are no supply blockages or leaks. Increase pressure. Max:90psi
Static electricity.	1. Dry weather conditions.	1. Leave the workpiece to stand for a while.
Blast pattern too wide or ineffective.	1. Nozzle blocked or worn.	1. Unblock or replace nozzle

**NOTE:** It is our policy to continually improve products and as such we reserve the right to alter data, specifications and component parts without prior notice.

**IMPORTANT:** No liability is accepted for incorrect use of this product.

**WARRANTY:** Guarantee is 12 months from purchase date, proof of which will be required for any claim.

**INFORMATION:** For a copy of our latest catalogue and promotions call us on 01284 757525 and leave your full name and address, including postcode.



Sole UK Distributor, Sealey Group,  
Kempson Way, Suffolk Business Park,  
Bury St. Edmunds, Suffolk,  
IP32 7AR



01284 757500



www.sealey.co.uk



01284 703534



sales@sealey.co.uk

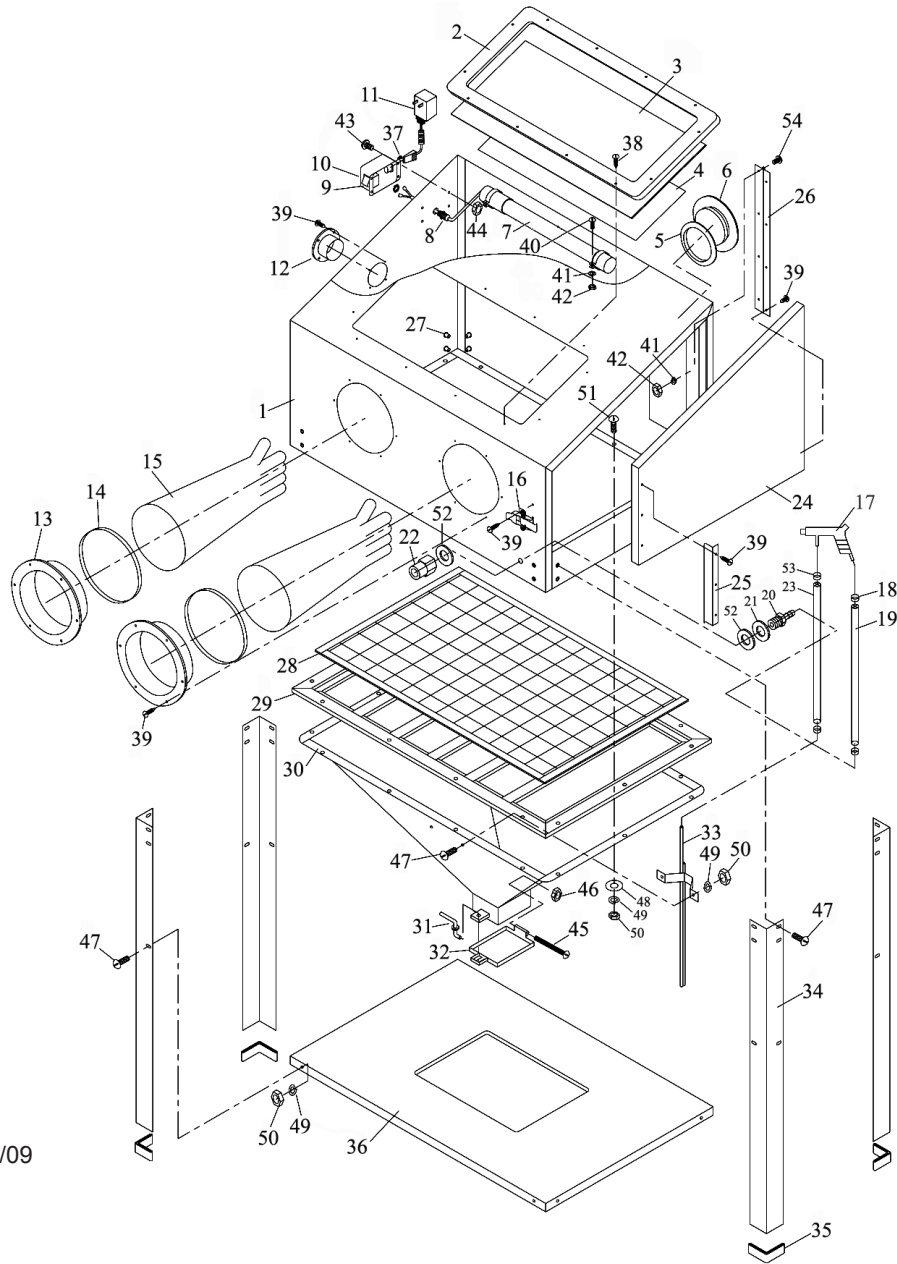

Issue: 2  
 Issue Date: 03/04/09

ITEM	PART NO	DESCRIPTION	ITEM	PART NO	DESCRIPTION	ITEM	PART NO	DESCRIPTION
1	SB973.V3-01	CABINET	19	SB973.V3-19	AIR HOSE	37	SB973.V3-37	TAPPING SCREW
2	SB973.V3-02	FRAME	20	SB973.V3-20	AIR HOSE (TIE-IN)	38	SB973.V3-38	TAPPING SCREW
3	SB973.V3-03	GLASS BOARD	21	SB973.V3-21	WASHER	39	SB973.V3-39	TAPPING SCREW
4	SB973.V3-04	PROTECTION FILM	22	SB973.V3-22	AIR COMPRESSOR (TIE-IN)	40	SB973.V3-40	BOLT (M4x20)
5	SB973.V3-05	RUBBER CIRCLE	23	SB973.V3-23	SUCTION HOSE	41	SB973.V3-41	SPRING WASHER
6	SB973.V3-06	INTAKE VENT COVER	24	SB973.V3-24	DOOR	42	SB973.V3-42	NUT M4
7	SB973.V3-07	LIGHT ASSEMBLY	25	SB973.V3-25	LINER	43	SB973.V3-43	BOLT (M5x8)
8	SB973.V3-08	WIRE CLAMP	26	SB973.V3-26	HINGE	44	SB973.V3-44	NUT M5
9	SB973.V3-09	SWITCH	27	SB973.V3-27	INSERT NUT	45	SB973.V3-45	BOLT M5x50
10	SB973.V3-10	SWITCH BOX	28	SB973.V3-28	SCREEN	46	SB973.V3-46	LOCK NUT M5
11	SB973.V3-11	TRANSFORMER	29	SB973.V3-29	SCREEN FRAME	47	SB973.V3-47	BOLT M6x12
12	SB973.V3-12	SUCTION FLANGE	30	SB973.V3-30	CABINET FUNNEL	48	SB973.V3-48	WASHER
13	SB973.V3-13	GLOVES FLANGE	31	SB973.V3-31	COVER LOCK	49	SB973.V3-49	SPRING WASHER
14	SB973.V3-14	GLOVES CLAMP	32	SB973.V3-32	ABRASIVE COVER	50	SB973.V3-50	NUT M6
15	SB973.V3-15	GLOVES (PAIR)	33	SB973.V3-33	ABRASIVE SUCTION PIPE	51	SB973.V3-51	BOLT M6x25
16	SB973.V3-16	LATCH	34	SB973.V3-34	LEG	52	SB973.V3-52	RUBBER WASHER
17	SB973.V3-17	SANDING GUN	35	SB973.V3-35	FEET	53	SB973.V3-53	HOSE CLAMP
18	SB973.V3-18	HOSE CLAMP	36	SB973.V3-36	SHELF	54	SB973.V3-54	BOLT M4x12
						55	SB973.V2-35	GUN NOZZLE (CERAMIC 4,5,6 & 7MM)