

Thank you for purchasing a Sealey product. Manufactured to a high standard this product will, if used according to these instructions and properly maintained, give you years of trouble free performance.

**⚠ IMPORTANT: PLEASE READ THESE INSTRUCTIONS CAREFULLY. NOTE THE SAFE OPERATIONAL REQUIREMENTS, WARNINGS & CAUTIONS. USE THE PRODUCT CORRECTLY AND WITH CARE FOR THE PURPOSE FOR WHICH IT IS INTENDED. FAILURE TO DO SO MAY CAUSE DAMAGE AND/OR PERSONAL INJURY AND WILL INVALIDATE THE WARRANTY. PLEASE KEEP INSTRUCTIONS SAFE FOR FUTURE USE.**

## 1. SAFETY INSTRUCTIONS

### 1.1. ELECTRICAL SAFETY

**WARNING!** It is the responsibility of the owner and the operator to read, understand and comply with the following:  
 You must check all electrical products, before use, to ensure that they are safe. You must inspect power cables, plugs, sockets and any other connectors for wear or damage. You must ensure that the risk of electric shock is minimised by the installation of appropriate safety devices. A Residual Current Circuit Breaker (RCCB) should be incorporated in the main distribution board. We also recommend that a Residual Current Device (RCD) is used. It is particularly important to use an RCD with portable products that are plugged into a supply which is not protected by an RCCB. If in any doubt consult a qualified electrician. You may obtain a Residual Current Device by contacting your Sealey dealer. **You must** also read and understand the following instructions concerning electrical safety.

- 1.1.1. The **Electricity at Work Act 1989** requires all portable electrical appliances, if used on business premises, to be tested by a qualified electrician, using a Portable Appliance Tester (PAT), at least once a year.
- 1.1.2. The **Health & Safety at Work Act 1974** makes owners of electrical appliances responsible for the safe condition of those appliances and the safety of the appliance operators. **If in any doubt about electrical safety, contact a qualified electrician.**
- 1.1.3. Ensure that the insulation on all cables and on the appliance is safe before connecting it to the power supply. See 1.1.1. and 1.1.2. and use a Portable Appliance Tester.
- 1.1.4. Ensure that cables are always protected against short circuit and overload.
- 1.1.5. Regularly inspect power supply cables and plugs for wear or damage and check all connections to ensure that none are loose.
- 1.1.6. **Important:** Ensure that the voltage marked on the appliance matches the power supply to be used and that the plug is fitted with the correct fuse - see fuse rating at right.
- 1.1.7. **DO NOT** pull or carry the appliance by the power cable.
- 1.1.8. **DO NOT** pull the plug from the socket by the cable.
- 1.1.9. **DO NOT** use worn or damaged cables, plugs or connectors. Immediately have any faulty item repaired or replaced by a qualified electrician. When an ASTA/BS approved UK 3 pin plug is damaged, cut the cable just above the plug and **dispose of the plug safely.** Fit a new plug according to the following instructions (UK only).
  - a) **Connect the GREEN/YELLOW earth wire to the earth terminal 'E'.**
  - b) **Connect the BROWN live wire to the live terminal 'L'.**
  - c) **Connect the BLUE neutral wire to the neutral terminal 'N'.**
  - d) **After wiring, check that there are no bare wires, that all wires have been correctly connected, that the cable outer insulation extends beyond the cable restraint and that the restraint is tight.**

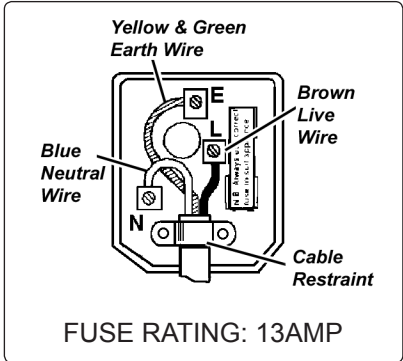

Double insulated products, which are always marked with this symbol , are fitted with live (brown) and neutral (blue) wires only. To rewire, connect the wires as indicated above - **DO NOT** connect either wire to the earth terminal.

- 1.1.10. Products which require more than 13Amps are supplied without a plug. In this case you must contact a qualified electrician to ensure that a 30 Amp supply is available. We recommend that you discuss the installation of an industrial round pin plug and socket with your electrician.
- 1.1.11. If an extension reel is used it should be fully unwound before connection. A reel with an RCD fitted is preferred since any appliance plugged into it will be protected. The section of the cores in the cable is important and should be at least 1.5mm<sup>2</sup>, but to be absolutely sure that the capacity of the reel is suitable for this product and for others which may be used in the other output sockets, we recommend the use of 2.5mm<sup>2</sup> section cable.

### 1.2. GENERAL SAFETY INSTRUCTIONS

- ✓ **Familiarise** yourself with the application and limitations of the compressor.
- ✓ Ensure that the compressor is in good order and condition before use. If in any doubt do not use. Contact an electrician or your service agent.
- WARNING!** *the compressor must be serviced by an authorised agent only. DO NOT tamper with, or attempt to adjust, the pressure switch or the safety valve.*
- ✓ Before moving or maintaining the compressor, ensure that it is unplugged from the mains supply and that the air tank pressure has been vented.
- ✓ Only use recommended parts and accessories. Using unauthorised items may be dangerous and will invalidate your warranty.
- ✓ Read the instructions regarding any air tool/accessory used with the compressor. Ensure that the safe working pressure of any air tool/accessory used exceeds the output pressure of the compressor.
- ✓ Keep tools and other items away from the compressor when it is in use and keep the area clean and free of unrelated items.
- ✓ Ensure that the air hose is not tangled, twisted or pinched.
- ✓ Keep children and unauthorised persons away from the work area.
- X **DO NOT** dis-assemble compressor for any reason. The unit must be checked by qualified personnel only.
- X **DO NOT** use the compressor outdoors, or in damp or wet locations and **DO NOT** operate it within the vicinity of flammable liquids, gases or solids.
- X **DO NOT** touch compressor cylinder, cylinder head or pipe from head to tank, as these may be hot and will remain so for some time after shutdown.
- X **DO NOT** attempt to move the compressor by pulling the air supply hose.
- X **DO NOT** attempt to lift or move the compressor by any means other than by the handle.
- ✓ Remove ill fitting clothing, ties, watches, rings and other loose jewellery and contain long hair.
- ✓ Wear approved safety eye protection (standard spectacles are not adequate).
- ✓ Use the compressor in a well ventilated area, keeping the air vents clear of obstructions.
- X **DO NOT** restrict air flow around the compressor whilst operating it.
- ✓ Ensure that it is placed on a firm, level surface.
- X **DO NOT** operate the compressor if you are tired or under the influence of alcohol, drugs or intoxicating medication.

- X DO NOT use this compressor to perform a task for which it is not designed.
- X DO NOT deface the certification plate attached to the compressor tank.
- ▲ **DANGER! DO NOT direct the output jet of air towards people or animals.**
- X DO NOT operate the compressor without an air filter.
- X DO NOT allow anyone to operate the compressor unless they have received full instruction.
- ☐ **WARNING! The air tank is a pressure vessel and the following safety measures apply:**
- X DO NOT tamper with the safety valve and DO NOT modify or alter the tank in any way and DO NOT strap anything to the tank.
- X DO NOT subject the tank to impact, vibration or to heat and DO NOT allow contact with abrasive or corrosive materials.
- ✓ DO drain condensation from tank daily and inspect inside walls for corrosion every three months. Have a detailed tank inspection carried out annually. The tank shell must not fall below the certified thickness at any point.
- ☐ **WARNING! If an electrical fuse blows, ensure that it is replaced with one of identical type and rating.**
- ✓ When not in use, disconnect from the mains, vent the tank and store the compressor in a safe, dry, childproof location.
- ✓ When the compressor is not in use, it should be switched off, disconnected from the mains supply and the air drained from the tank.

## 2. INTRODUCTION & SPECIFICATION

Compact and portable, this compressor is suitable for use with the Sealey range of air nailers, tyre inflators and air brushes. Fitted with twin gauges displaying tank and working pressures. Features four anti-vibration rubber feet for added stability when in use.

Motor output: . . . . .	1.5hp	Max. free air delivery: . . . . .	3.4cfm
Voltage/phase: . . . . .	230V/1ph	Tank capacity: . . . . .	6ltr
Current: . . . . .	4.8A	Max pressure: . . . . .	116psi/8bar
Air displacement: . . . . .	4.8cfm	Noise level: . . . . .	95dB.A

## 3. PREPARATION

- ☐ **WARNING! The compressor is supplied with synthetic lubricating oil in the pump - see para. 5.4.**
- 3.1. Remove compressor from packaging and inspect for any shortages or damage. If there are any problems contact your supplier.
- 3.2. Confirm that the mains voltage corresponds with the voltage shown on the compressor data plate.
- 3.3. The compressor should be installed on a flat surface, or one that does not exceed 10° either transversely or longitudinally, and should be in a position that allows good air circulation around the unit with at least 100cm between it and any other objects.
- 3.4. **IMPORTANT! Remove the oil dipstick from the pump (fig.2), wipe it clean, re-insert it and then remove it and check that the oil level is correct (fig.3). Add oil if required until the level is correct. Replace the dipstick. DO NOT ATTEMPT TO RUN THE COMPRESSOR UNTIL THIS HAS BEEN CHECKED.**
- 3.5. Take care when selecting tools for use with the compressor. Air tool manufacturers normally express the volume of air required to operate a tool in cubic feet per minute (cfm). This refers to free air delivered by the compressor ('air out') which varies according to the pressure setting. Do not confuse this with the compressor displacement which is the air taken in by the compressor ('air in'). 'Air out' is always less than 'air in' - due to losses within the compressor - so it is important that before choosing equipment, the correct Air Displacement figures are adhered to.

## 4. OPERATION

- ☐ **WARNING! ENSURE THAT YOU HAVE READ, UNDERSTOOD AND APPLIED SECTION 1 SAFETY INSTRUCTIONS.**

**Note: DUTY CYCLE:** This is a 70% duty cycle air compressor. Do not run the air compressor for more than approximately 40 minutes in any one hour. Doing so could damage the compressor.

- 4.1. Make sure that the main switch (fig.1.1) is 'Off' (pushed down).
  - 4.2. Check the oil level by checking the dipstick (figs.2 and 3).
  - 4.3. Ensure that the tank drain valve is closed (fig.5).
  - 4.4. Ensure that the outlet pressure regulator is not at full pressure (fully clockwise), if it is, turn the knob anti-clockwise a few turns (fig.1.2).
  - 4.5. Connect the required air tool to the compressor via an air line connected to the air outlet (fig.1.4).
  - 4.6. Plug the mains cable into the mains supply and start the compressor by pulling up the main switch into the 'On' position (fig.1.1).
  - 4.7. Allow the pressure in the tank to rise to the maximum at which point the compressor will automatically cut out. Tank pressure is shown on the larger gauge (fig.1.6).
  - 4.8. Begin to gradually increase the pressure regulator by turning the knob clockwise until the small gauge registers the required operating pressure specified for the tool connected. Always **adjust up** to the required pressure rather than down from a higher pressure. The required setting, once achieved, can be locked by screwing the locking ring (fig.1.3) up tight underneath the adjusting knob.
  - 4.9. Commence using the air tool. The compressor will operate automatically, cutting in and out as required to restore the air pressure in the tank. The pressure switch (fig.1.8) stops the motor when the maximum tank pressure is reached and restarts it when pressure falls below the minimum threshold - approximately 2bar (29psi) less than the maximum pressure.
- Note:**
- a) If the motor does not cut in and out, but runs continuously when using an air appliance, the capacity of the compressor may be too small for the appliance.
  - b) The main gauge (fig.1.6) indicates the pressure inside the main tank, **NOT** the pressure supplied to the air equipment, this is shown on the smaller gauge (fig.1.5). Should the pressure in the main tank exceed the pre-set pressure switch maximum, the safety valve (fig.1.7) will activate. **WARNING! For this reason DO NOT tamper with, or adjust, the switch or the safety valve.** (When the compressor is not being used, set the regulated pressure to zero so as to avoid damaging the pressure regulator).
- 4.10. To stop the compressor, press down the main switch (fig.1.1). When the compressor stops there will be a whistling sound as compressed air is vented from the compressor head. **DO NOT**, other than in an emergency, stop the compressor by switching off at the mains socket, or by pulling the plug out, as the pressure relief will not then occur and motor damage may result upon restart.

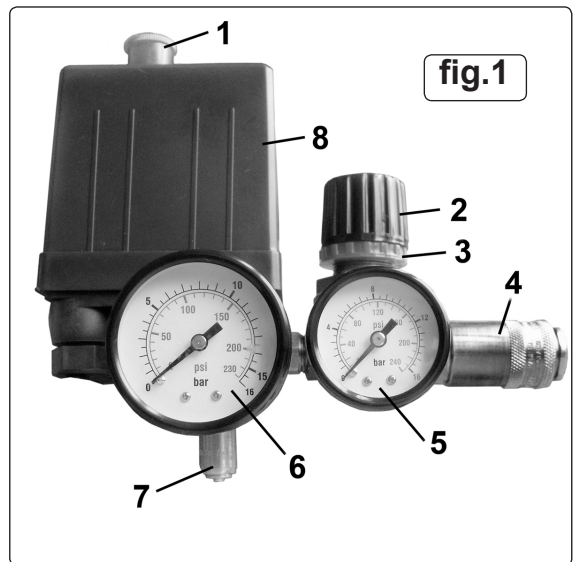

- 4.11. When finished using the compressor, unplug the unit from the mains power supply.
- 4.12. Set the outlet pressure regulator to zero by turning the knob anti-clockwise.
- 4.13. Disconnect the air line/air tool.
- 4.14. The tank must be drained, this will release the air left in the tank and drain away any condensation that may have formed within the tank. Choose a suitable location for this operation and/or make provision to collect the condensation. **Wear ear and eye protection.** Open the tank drain valve (fig.5) slowly allowing air and moisture to bleed from the tank. After bleeding, close the drain valve to prevent debris building up in the valve.
- WARNING! Water that is allowed to remain in the tank during storage will corrode and weaken the air tank which could cause the tank to rupture. To avoid serious injury, drain the tank after each use or daily.**
- 4.15. **SAFETY FEATURES.**  
**Thermal cut out:** If the unit overheats, the thermal cut out will operate and shut the unit down. The thermal cut out will automatically reset when the unit has cooled down - which may take 10 to 15 minutes.

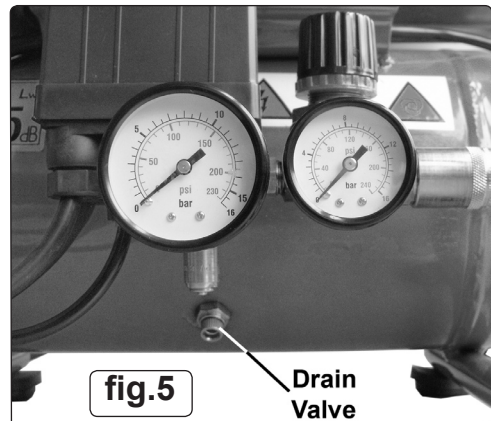
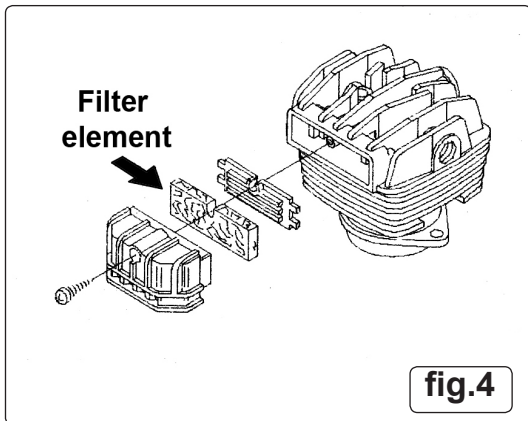
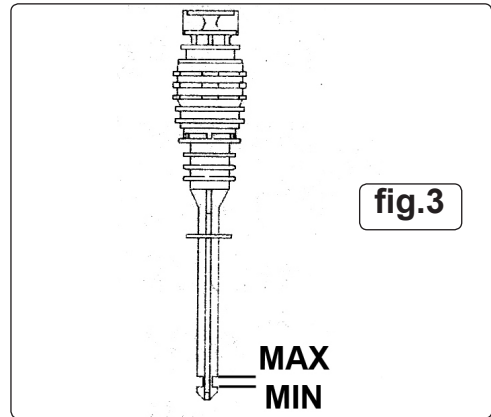
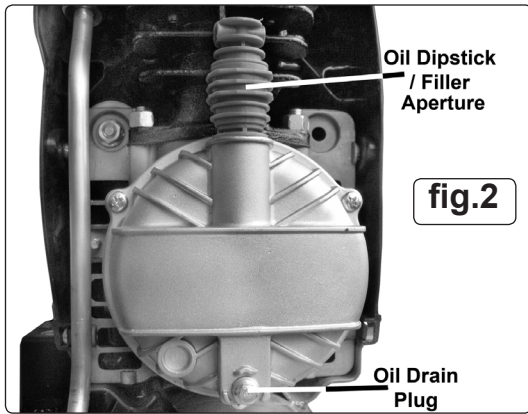

## 5. MAINTENANCE

- WARNING!** Before performing any maintenance, switch off the compressor, disconnect from the electricity supply, release all air from the tank and turn the regulator off (fully clockwise). In order to keep the compressor in good working condition, periodical maintenance is essential.
  - 5.1. **After the first 100 working hours, replace the lubricating oil - see section 5.4b below.**
  - 5.2. **TO BE CARRIED OUT DAILY:**
    - a) Drain condensation from the tank. See 4.14. above.
    - b) Check for oil leaks.
    - c) Check oil level and top up if necessary.
  - 5.3. **TO BE CARRIED OUT WEEKLY:**
    - a) Remove the filter element (fig.4) and check its condition. Unclip the end plastic safety cover (3 clips) and lift it away. Remove the cross-head screw in the filter cover and prise out the foam filter element. Clean it by blowing through with an air line at low pressure, or wash it in soapy water, rinse and dry. Refit filter and the cover. Do not operate the compressor without the filter as foreign matter or dust could seriously damage the pump.
  - 5.4. **TO BE CARRIED OUT AFTER EVERY 100 HOURS OF USE:**
    - a) Check that the automatic cut-out at maximum pressure, and the automatic cut-in at 2bar below that, are operating correctly.
    - b) Replace the lubricating oil. For oil specifications see below.  
Remove the oil drain plug (fig.2), draining the oil into a suitable container. Drain when the compressor is hot so that oil drains rapidly and completely. Incline compressor if needed to ensure complete drainage. Replace the oil drain plug and pour oil through the filler/dipstick aperture. Check oil level with dipstick (fig.3) and **DO NOT** overfill.  
**Recommended oil:** The pump is filled with synthetic oil at the factory, if topping up or changing oil use a synthetic oil of SAE 5W50 viscosity. Alternatively a mineral oil can be substituted when carrying out an oil change, after ensuring that the synthetic oil has been thoroughly drained first. Use a mineral oil of SAE 15W40 viscosity.
  - WARNING! Do not mix different oils and do not use non-detergent/low quality oils, as the compressor may be damaged. Dispose of all waste oil responsibly, in accordance with local authority requirements.**
  - 5.5. **TO BE CARRIED OUT AFTER EVERY 500 HOURS OF USE:**
    - a) Replace air filter.
    - b) Check all tube fittings and electrical connections.
    - c) Check all screws, nuts and bolts are tightly in place.
    - d) Inspect pressure tank inside and out for damage or corrosion.
- IMPORTANT! Failure to carry out maintenance tasks may invalidate the warranty on your compressor.**

**5.6. IMPORTANT WARNING -**

Air contaminants taken into the compressor will affect optimum performance. Example: Body filler dust or paint overspray will clog the pump intake filter and may cause internal damage to pump/motor components. Please note that any parts damaged by any type of contamination will not be covered by warranty.

**6. TROUBLESHOOTING**

FAULT	CAUSE	REMEDY
1A) Pressure drop in the tank.	Air leaks at connections.	Run compressor to max. pressure, switch off. Brush soap solution over connections and look for bubbles. Tighten connections showing leaks. If problem persists contact Authorised Service Agent.
1B) Pressure drop in the tank.	Air leaks from safety valve.	Operate the safety valve manually. If valve continues to leak when in the closed position it should be replaced.
1C) Pressure drop in the tank.	Air leaks from cylinder head gasket.	Check tightness of head bolts. If leak continues contact authorised service agent.
2) Pressure switch valve leaks when compressor is idle.	Non-return valve seal defective.	Empty the air tank, remove the non-return valve cap and clean, or if necessary, replace the seal.
3) Air leaks from tank body or tank welds.	Internal corrosion caused by infrequent tank draining or non permitted modifications to tank.	Tank could rupture or explode. Cannot be repaired. <b>DISCONTINUE USE IMMEDIATELY.</b>
4A) Motor stops and will not restart.	Thermal cut out has operated.	Allow to cool for 10 to 15 minutes before restarting.
4B) Motor stops and will not restart.	Plug fuse has burnt out.	Replace fuse and restart unit. If repeat occurs, contact authorised service agent.
5) Compressor stops and does not restart.	Motor failure.	Contact Authorised Service Agent..
6A) Compressor does not stop at max. pressure.	Pressure switch fault..	Contact Authorised Service Agent.
6B) Compressor does not stop at max. pressure.	Filter clogged	Clean or replace filter element.
6C) Compressor does not stop at max. pressure.	Head gasket or valve fault.	Contact Authorised Service Agent.
7) Compressor noisy with metallic knock.	Bearing or piston damage.	Contact Authorised Service Agent.
8) Excessive moisture in discharged air.	High humidity environment.	Drain tank after each use.

**Environmental Protection.**



Recycle unwanted materials instead of disposing of them as waste. All tools, accessories and packaging should be sorted, taken to a recycle centre and disposed of in a manner which is compatible with the environment.



When the product is no longer required, it must be disposed of in an environmentally protective way.





**NOTE:** It is our policy to continually improve products and as such we reserve the right to alter data, specifications and component parts without prior notice.

**IMPORTANT:** No liability is accepted for incorrect use of this product.

**WARRANTY:** Guarantee is 12 months from purchase date, proof of which will be required for any claim.

**INFORMATION:** For a copy of our latest catalogue and promotions call us on 01284 757525 and leave your full name and address, including postcode.



	<b>Sole UK Distributor, Sealey Group,</b> Kempson Way, Suffolk Business Park, Bury St. Edmunds, Suffolk, IP32 7AR	 <b>01284 757500</b>	 <a href="http://www.sealey.co.uk">www.sealey.co.uk</a>
	 <b>01284 703534</b>	 <a href="mailto:sales@sealey.co.uk">sales@sealey.co.uk</a>	