



INSTRUCTIONS FOR:
CONVERSION KIT FOR RE230 SERIES
SPRING COMPRESSOR
 MODEL No: **RE230UK**

Thank you for purchasing a Sealey product. Manufactured to a high standard, this product will, if used according to these instructions, and properly maintained, give you years of trouble free performance.



IMPORTANT: PLEASE READ THESE INSTRUCTIONS CAREFULLY. NOTE THE SAFE OPERATIONAL REQUIREMENTS, WARNINGS & CAUTIONS. USE THE PRODUCT CORRECTLY AND WITH CARE FOR THE PURPOSE FOR WHICH IT IS INTENDED. FAILURE TO DO SO MAY CAUSE DAMAGE AND/OR PERSONAL INJURY AND WILL INVALIDATE THE WARRANTY. KEEP THESE INSTRUCTIONS SAFE FOR FUTURE USE.

1. SAFETY

GENERAL SAFETY.

- WARNING!** Ensure Health & Safety, local authority, and general workshop practice regulations are adhered to when using this equipment.
- WARNING!** Wear approved safety hand and eye protection (standard spectacles are not adequate).
- WARNING! TRAPPING DANGER** – Keep hands and fingers away from the spring and compressing yokes in use.
- ✓ Keep the work area clean, uncluttered and ensure there is adequate lighting.
- ✓ Maintain correct balance and footing. Ensure the floor is not slippery and wear non-slip shoes.
- ✓ Remove ill-fitting clothes. Remove ties, watches, rings, other loose jewellery. Contain and/or tie back long hair.
- ✓ Wear appropriate protective clothing.
- ✓ Familiarise yourself with the applications, limitations and potential hazards of the spring compressor.
- ✗ **DO NOT** force the spring compressor to achieve a task it was not designed to perform.
- ✗ **DO NOT** allow untrained persons to use the spring compressor.

PRE OPERATIONAL SAFETY.

- ✓ Coil Spring Compression station should be securely bolted to the workshop floor before use.
- ✓ Apply grease to the front and rear faces of the main upright to assist the smooth action of the compressor.
- ✗ **DO NOT** operate spring compressor if parts are damaged or missing as this may cause failure and/or personal injury.
- ✓ Before commencing compression, make visual inspection of machine to ensure pins are securely positioned and that there is no sign of wear or fatigue – if found, do not use the unit and refer to your local Sealey dealer for advice and replacement parts.
- ✓ Ensure yoke locating pins are properly positioned and safety clips are attached correctly.
- ✓ Before commencing compression of spring, ensure coils of the spring are seated securely in the yokes of the compressor and cannot slide out during compression.
- ✓ Always fit the safety chain around strut and spring (ensure chain is not trapped in the coils of the spring as compressed).

OPERATIONAL SAFETY.

- ✓ When applying compression to the spring, always stand to one side of the unit.
- ▲ **DANGER!** Stop compressing the spring before the coils touch.
- ✓ Before attempting to remove top cap nut, always use a tool or short stick to test if the compression has been relieved. **DO NOT** use your hands or fingers.
- ✓ We recommend the use of purpose made strut tools to remove the top-nut from the shock piston.
- ✓ Once compressed, and the strut removed, we recommend releasing the tension on the spring. **DO NOT** leave the spring under compression in the machine unattended and do not leave in compression for prolonged periods, i.e. overnight.
- ✓ Before releasing the compression ensure that the top strut-nut is securely fastened to the maker's tolerance.
- ✓ Release the compression slowly keeping your hands and fingers away from the spring assembly.
- ✓ Be sure that the tension on the spring is fully controlled by the strut assembly before removing it from the yokes of the compressor.

POST OPERATIONAL SAFETY.

- ✓ When not in use, clean and store the spring compressor in a safe, dry, childproof location.
- ✓ Maintain the spring compressor in good condition. Replace or repair damaged parts. *Use genuine parts only. Unauthorised parts may be dangerous and will invalidate the warranty.*
- WARNING!** The warnings, cautions and instructions in this manual cannot cover all possible conditions and situations that may occur. It must be understood by the operator that common sense and caution are factors which cannot be built into this product, but must be applied by the operator.

2. INTRODUCTION

The RE230UK kit enables the RE230 spring compressor to be fitted with an improved type of clamping jaw and yoke. The system allows removal of the shock absorber from the spring without the need to remove the assembly from the compressor. The plastic coated yokes reduce the risk of spring slippage and are suitable for springs from Ø80mm to Ø175mm. Before use, you must read the safety guide on this page and the revised instructions for use. When fitted the unit will conform to the technical specification below.

3. SPECIFICATION

Maximum Load: 1500kg
 Lower Yoke Travel:..... 340mm
 Spring Diameter Range:80-175mm
 Upper Yoke positions:..... 7

4. CONTENTS

Item	Description (Main Items)	Qty
8	Pre-assembled lower strut support	1
16	Pre-assembled upper strut support	1
9A	Coil compression yokes (Ø80mm-Ø130mm)	2
9B	Coil compression yokes (Ø100mm-Ø175mm)	2
13	Safety chain	2

See separate parts list for fuller parts listing; pins, clips fixings etc..

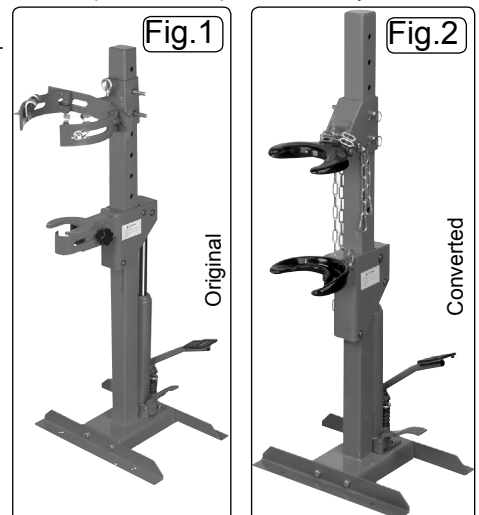

5. ASSEMBLY

- 5.1. Remove both strut support brackets from the existing unit. From Fig.3 remove the clips positions "E" and "G" from the two extended location pins, positions "D" and "F" in the top support bracket and pin. Support the bracket whilst removing the extended pins, slide the bracket up and off the box section column. Retain the pins and clips.
- 5.2. In Fig.4 the lower strut bracket is attached to the ram clevis with a pin, circlip and a clip. Slacken the socket set screw "Z" from the ram clevis. Supporting the bracket and ram, slide the bracket up and off the box section column.
- 5.3. The new yokes shown in Fig.5 can be fitted at any stage. As they are shown in Fig.6 and Fig.7, it is best explained at this stage. Two pairs of yokes are supplied, 'small' and 'large'. Designed as matched pairs; hold the chosen yoke in place within each support bracket and retain with the supplied pin "K" and clips "L". **DO NOT** assemble 'small' with 'large' yoke, fit 2 'small' or 2 'large' yokes in the same setting. Finally clamp with the socket head cap screw "J".
- 5.4. The new lower strut support bracket is supplied with a fitted pin mounted clevis; arrow "A" Fig.6. Slide the new lower strut support bracket over the column in direction "X" and ensure the ram rod enters the clevis full depth. Tighten the socket set screw.
- 5.5. Slide the new upper strut support bracket in the direction of arrow "Y" in Fig.7 to a required height of seven possible positions. Align two holes in the strut to two holes in the column, slide two extended location pins "D" and "F" through and retain with the clips.
- 5.6. Two pairs of yokes are supplied, 'small' and 'large'. Designed as matched pairs with counter bored bosses for assembly to the stub shaft (spigot) of the strut support brackets, see Fig.3. Retain with the supplied pin and clips. **DO NOT** assemble 'small' with 'large' yoke, fit 2 'small' or 2 'large' in the same setting.
- 5.7. Safety chain fitting is covered in the "OPERATION" section.

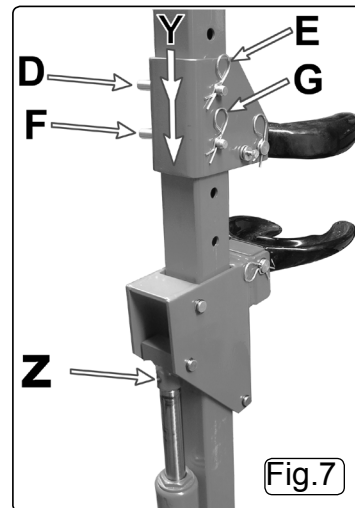
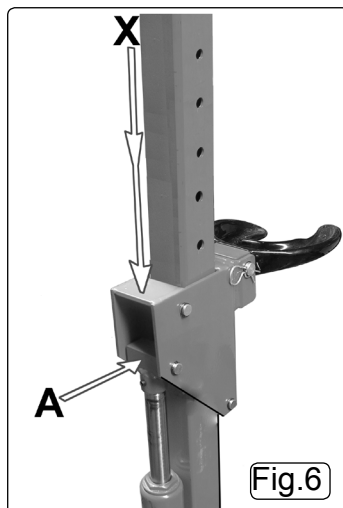
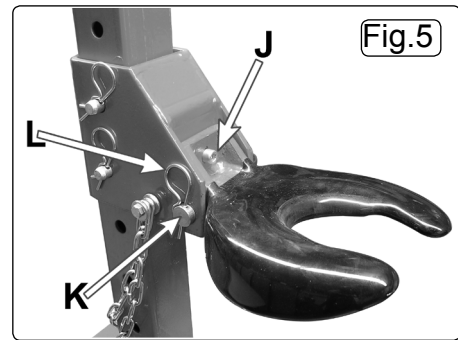
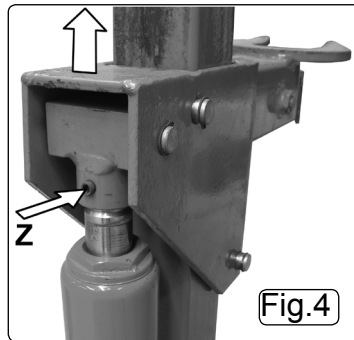
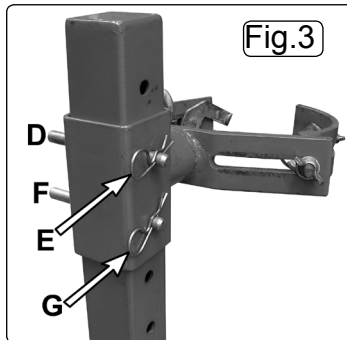

6. OPERATION

- 6.1. Measure the outer diameter of the spring to be compressed and select the correct set of yokes. Fit the yokes as described in section 5.3.
- 6.2. Operate the release valve pedal in Fig.8 and press down on the lower strut support until the piston is full retracted.
- 6.3. The upper yoke should bear down on the first full coil down from the top of the strut. The lower yoke should be pushing up on the first full coil up from the bottom of the strut. Measure the distance between these coils and adjust the position of the upper strut support so that the distance between the yokes is slightly larger than required. Ensure that the pins fixing the upper support are fully inserted and retained with the spring clips provided. Use the foot pedal to raise the lower yoke/strut support to finely adjust the distance between the yokes.
- 6.4. Before commencing compression, make a visual inspection of machine to ensure pins are securely positioned and that there is no sign of wear or fatigue; if found, **DO NOT** use the unit and refer to your local Sealey dealer for advice and replacement parts.
- 6.5. Insert the strut into the yokes and ensure that the lower coil used lies behind the retaining rim at the back of the yokes. Operate the foot pedal to raise the upper coil into contact with the upper yoke ensuring once again that the coil is retained by the raised rim within the yoke.
- 6.6. Wrap one safety chain around the portion of the spring and strut protruding from the upper yoke ensuring that the chain lies above the yoke. Wrap the other chain around the spring and strut protruding from the lower yoke ensuring that the chain lies below the yoke. Fasten each chain behind the main pillar using the sprung catches attached. Make sure each chain is as tight as possible. **DO NOT** position the chain between the coils held between the yokes.
- 6.7. When applying compression to the spring, always stand to one side of the unit.
- 6.8. Gradually compress the spring by pumping the foot pedal ensuring that the spring and strut remain securely held at all times. Ensure that the strut and the body of the compressor are correctly aligned at all times during spring compression. For conical springs, the centre line of the spring should remain parallel to the compressor body.
- DANGER!** Stop compressing the spring before the coil windings touch. You need only compress the spring until the strut top plate is free from the spring.
- 6.9. Before attempting to remove top cap nut, always use a tool or short stick to test if the spring compression has been relieved from the top plate. **DO NOT** use your hands / fingers. Sealey recommends the use of purpose made strut tools to remove the top-nut from the shock piston. Ensure that the shock absorber is supported as the top nut is undone to prevent it falling down through the coils and causing injury.

- 6.10. Once compressed, and the strut removed, we recommend releasing the tension on the spring. **DO NOT** leave the spring under compression in the machine unattended and do not leave in compression for prolonged periods. i.e. overnight.
- 6.11. Allow the spring to gradually decompress by carefully operating the valve release pedal keeping your hands and fingers away from the spring assembly.
- 6.12. Replace the spring or shock absorber as necessary and reassemble the strut by first compressing the spring and then introducing the shock absorber up through the lower yoke and compressed spring coils. Reattach the top plate and top nut.
- 6.13. Before releasing the compression ensure that the top strut nut is securely fastened to the maker's tolerance.
- 6.14. Release the compression slowly keeping your hands and fingers away from the spring assembly.
- 6.15. Be sure that the tension on the spring is fully controlled by the strut assembly before removing it from the yokes of the compressor.

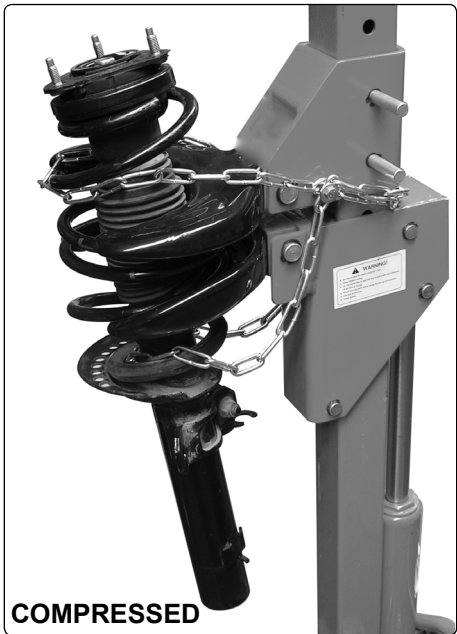
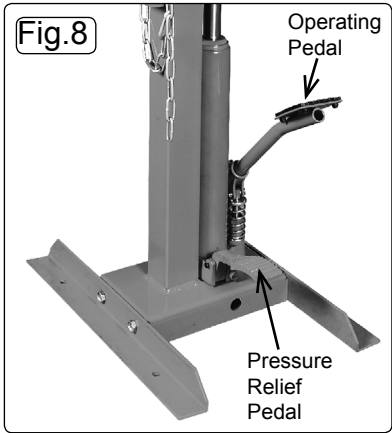

7. MAINTENANCE

- 7.1. Before each use, check the compressor to ensure it is not damaged or worn. If in any doubt **DO NOT** use the unit. Remove it from service immediately and contact your local Sealey dealer for advice/repairs.
- 7.2. Refilling the hydraulic system with oil is rarely necessary but the level should be checked in the event of a loss of performance. To check oil level, ensure the ram is fully lowered, remove filler plug and check that level is within 10mm of filler hole. Add hydraulic jack oil if necessary.

NOTE: Use a good quality jack oil, such as SEALEY HYDRAULIC JACK OIL.

- WARNING: DO NOT** use brake fluid, or any fluid other than hydraulic jack oil as this will cause serious damage and will invalidate the warranty!



Environmental Protection

Recycle unwanted materials instead of disposing of them as waste. All tools, accessories and packaging should be sorted, taken to a recycling centre and disposed of in a manner which is compatible with the environment. When the product becomes completely unserviceable and requires disposal, drain off any fluids (if applicable) into approved containers and dispose of the product and the fluids according to local regulations.

NOTE: It is our policy to continually improve products and as such we reserve the right to alter data, specifications and component parts without prior notice. **IMPORTANT:** No liability is accepted for incorrect use of this product.

WARRANTY: Guarantee is 12 months from purchase date, proof of which will be required for any claim.

INFORMATION: For a copy of our latest catalogue and promotions call us on 01284 757525 and leave your full name and address, including postcode.





Sole UK Distributor, Sealey Group,
Kempson Way, Suffolk Business Park,
Bury St. Edmunds, Suffolk,
IP32 7AR

 **01284 757500**
 **01284 703534**

 www.sealey.co.uk
 sales@sealey.co.uk