

Thank you for purchasing a Sealey product. Manufactured to a high standard this product will, if used according to these instructions and properly maintained, give you years of trouble free performance.

⚠ IMPORTANT: PLEASE READ THESE INSTRUCTIONS CAREFULLY. NOTE THE SAFE OPERATIONAL REQUIREMENTS, WARNINGS & CAUTIONS. USE THE PRODUCT CORRECTLY AND WITH CARE FOR THE PURPOSE FOR WHICH IT IS INTENDED. FAILURE TO DO SO MAY CAUSE DAMAGE AND/OR PERSONAL INJURY AND WILL INVALIDATE THE WARRANTY. PLEASE KEEP INSTRUCTIONS SAFE FOR FUTURE USE.

1. SAFETY INSTRUCTIONS

- ❑ **WARNING!** Ensure Health & Safety, local authority and general workshop practice regulations are adhered to when using this equipment.
- ✓ Use a qualified person to lubricate and maintain the lift. **DO NOT** use brake fluid to top up hydraulic unit. Use Sealey hydraulic oil only.
- ✓ Replace or repair damaged parts. Use *genuine parts only*. *Unauthorised parts may be dangerous and will invalidate the warranty.*
- ✓ Keep the lift clean for best and safest performance.
- ✓ Locate the lift in a suitable work area. Keep area clean and tidy and free from unrelated materials, and ensure that there is adequate lighting.
- ❑ **WARNING!** Use lift on level and solid ground, preferably concrete. *Avoid tarmac since the lift may sink into the surface.*
- ✓ Maintain correct balance and footing. Ensure that the floor is not slippery and wear non-slip shoes.
- ✓ Keep children and non-essential persons away from the work area.
- ✓ Never operate the lift with a load heavier than 680kg. Ensure the load is evenly distributed on the platform and secured if necessary.
- ✓ Before lifting check that there are no overhead obstructions.
- ✓ When raised, insert the safety bar to keep the platform from lowering.
- ✓ When work is complete, check under the platform to ensure that there are no obstructions and that it is safe to lower the unit.
- ✗ **DO NOT** operate the lift if any parts are damaged or missing as this may cause failure and/or possible personal injury.
- ✗ **DO NOT** place any part of your body within or under the lift during use.
- ✗ **DO NOT** operate the lift when you are tired or under the influence of alcohol, drugs or intoxicating medication.
- ✗ **DO NOT** use the lift for any purpose other than that for which it is designed.
- ✗ **DO NOT** allow untrained persons to operate the lift.
- ✗ **DO NOT** make any modifications to the lift.
- ✗ **DO NOT** expose the lift to excessive moisture or allow it to get wet.
- ✓ Store lift in a dry, childproof environment when not in use.

2. INTRODUCTION AND SPECIFICATION

- 2.1 Introduction**
 All-steel construction with heavy-duty hydraulic ram. Supplied with separate, foot operated, hydraulic pump and reservoir unit. Features two additional side platforms for extra width. Ramp and platform made with chequer plate surface to ease loading and positioning of mini tractor/quad. Supplied with motorcycle front wheel locking attachment, securing vehicle to provide easy maintenance access. Fitted with safety lock to prevent accidental lowering. Suitable for use with centre stand motorcycles or with paddock stand.
- 2.2 Specification**
- | | |
|----------------------|-----------------|
| Model | MT680.V3 |
| Capacity | 680kg |
| Minimum Height | 190mm |
| Maximum Height | 790mm |
| Standard Width | 710mm |
| Maximum Width | 1220mm |
| Length | 2000mm |
| Table Size | 710 x 2000mm |
| Side Extension | 254 x 2000mm |

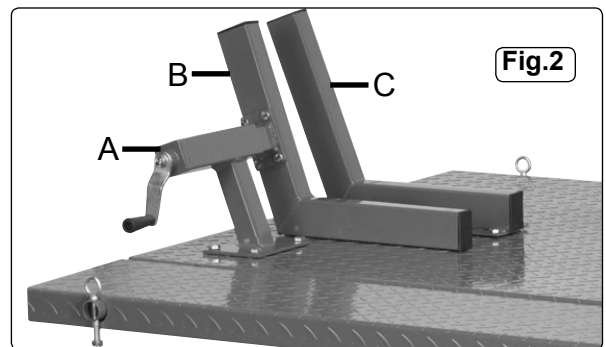

3. CONTENT & ASSEMBLY

- 3.1 Content**
- 3.1.1 The Vehicle Lift comprises:
 Main lift assembly. Leading plate. Manual hydraulic pump assembly. Side extensions. Ramp extensions. Connecting bar. Motorcycle Wheel Clamp. Bolts, nuts and washers.
- 3.2 Assembly (Refer to Fig 3.)**
- 3.2.1 Attach the sliding plate (8) to the platform using bolts, washers and nuts.
- 3.2.2 Connect the oil hose coupler (30) to the port on the hydraulic pump.
- 3.2.3 Attach the leading plate (9) to the end of the platform.
- 3.2.4 If necessary, when lifting vehicles, attach the two side extensions (51A) and (51) to the platform using the panel pipes (52) the pins (49), washers (50) and nuts (54).
- 3.2.5 Attach the ramp extensions (53) and (53A) to the side extensions.
- 3.3 Motorcycle Wheel Clamp**
- 3.3.1 Remove the clamp from the box and take the handle section (Fig.2A) and bolt to the top of the lift, through the pre-drilled holes, using large bolts, nuts and washers.
- 3.3.2 Next take the moving jaw (Fig.2B) and bolt it to the handle section with the small bolts supplied.
- 3.3.3 Finally take the fixed jaw (Fig.2C) and bolt it to the top of the lift, through the remaining holes, using large bolts, nuts and washers.

Fig.3

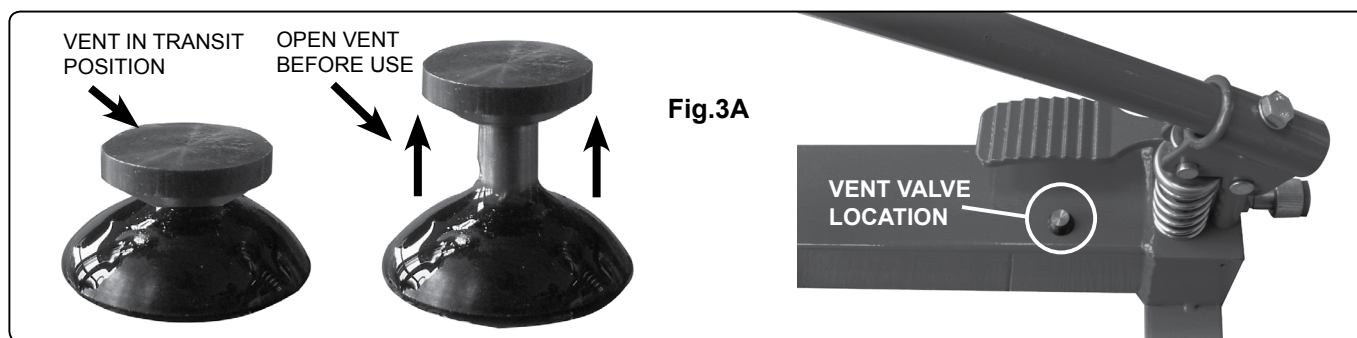
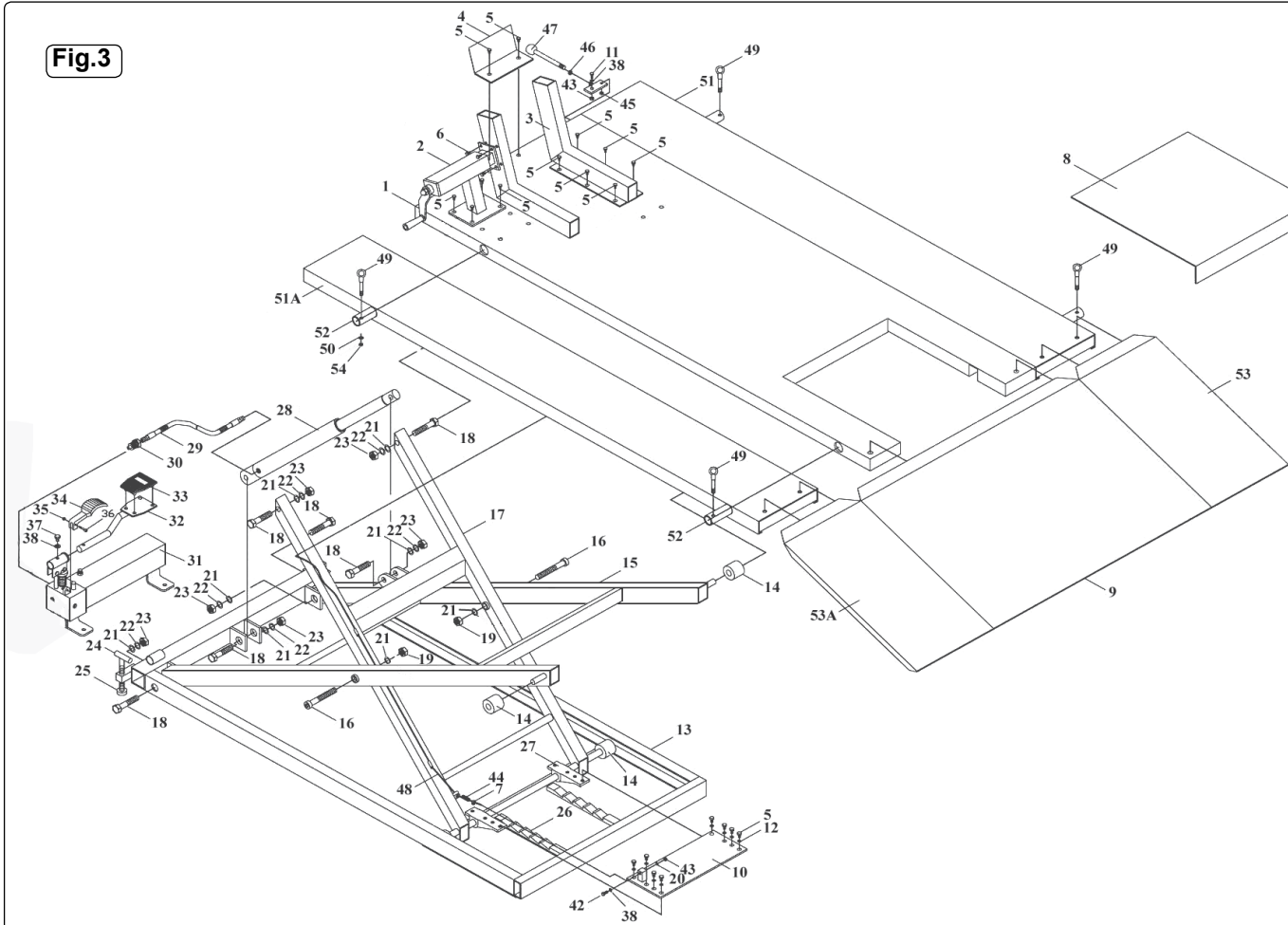

4. OPERATING INSTRUCTIONS

4.1 Prior To Use

NOTE! MT680 has a vent valve Fig.3A, this is closed for transit only; before use the valve must be lifted or the pump will not function properly.

4.1.1 Let the hydraulic pump stand for one hour, to allow the oil to settle, before purging the system.

NOTE: Failure to allow sufficient time for the oil to settle could result in air remaining in the oil. Should the pump fail to purge completely at the first attempt, a second purge will be required.

4.1.2 Purge the hydraulic system by depressing the release foot pedal (34) and pumping the lift foot pedal (32) fifteen to twenty times.

4.1.3 Test the lift unladen by moving the safety handle (47) to the right and raising the lift to full height.

4.1.4 Move the safety handle to the left (in the depression) and lower the lift by depressing the release foot pedal (34) slowly, to control the rate of descent.

4.2 Operation (Refer to the Parts Diagram)

WARNING! Ensure that you read, understand and apply the Section 1 Safety Instructions.

WARNING! DO NOT overload the Vehicle lift. The maximum load is 680kg.

4.2.1 Position the lift in a suitable location, preferably on a concrete surface.

4.2.2 Turn the locking plate base (27) down to ensure that lift is level and stable on the surface.

4.2.3 Wheel the vehicle up the leading plate and on to the lift platform.

WARNING! The vehicle must be fully supported by the lift platform prior to lifting. **DO NOT** put the rear wheel of the vehicle on the leading plate (9) and **DO NOT** use the leading plate to support the weight of the vehicle when lifting. The leading plate (9) is only used to assist the operator in wheeling the vehicle on the platform when the lift is at its lowest position.

4.2.4 Secure the vehicle securely to the lift platform. When working on a motorcycle, wheel the bike in to the wheel clamp at the front of the lift, tighten the clamp to hold the bike in place.

NOTE: Before raising the lift, move the safety handle (47) to the right hand side.

4.2.5 When the platform has been raised to the working height, stop pumping the lift foot pedal.

NOTE: Ensure the safety handle is to the right and the lock plate assembly (10) is locked in a corresponding pair of safety latches (26) to prevent accidental lowering.

4.2.6 When work is completed, remove all tools from underneath the lift before lowering.

4.2.7 Move the safety handle to the left hand side (in the depression) and lower the lift by slowly depressing the release foot pedal (39) to gently lower the vehicle.

NOTE: Lower the vehicle slowly, in a controlled fashion. Never allow the vehicle to lower rapidly.

4.2.8 When the lift is fully lowered, unsecure the vehicle and remove it from the lift.

5. MAINTENANCE

IMPORTANT: Only fully qualified personnel should attempt maintenance or repair on the vehicle lift.

x **DO NOT** use the lift if it is believed to have been subjected to abnormal shock or load. Inspect the lift and take appropriate action.

5.1 When the lift is not in use, it must be stored in the lowest position in a dry location to minimise ram and piston corrosion.

5.2 Keep the lift clean and wipe off any oil or grease with a clean rag. Lubricate all moving parts.

5.3 Periodically check the ram and piston for signs of corrosion. Clean exposed areas with a clean oil cloth.

5.4 On each occasion before use, check all parts of the lift. If any part is damaged or suspect, remove the lift from service and take the necessary action to repair the faulty part or parts.

5.5 Purge the hydraulic system to eliminate any air from the system if lift efficiency drops in the course of carrying out the procedures outlined at Section 4.

5.6 Check the hydraulic oil level. If it is inadequate, remove the rubber plug on the pump and add hydraulic oil as required.

WARNING! Only a good quality hydraulic oil, such as **SEALEY HYDRAULIC JACK OIL**, must be used. **DO NOT** use brake fluid.

IMPORTANT: NO RESPONSIBILITY IS ACCEPTED FOR THE INCORRECT USE OF THE LIFT.

Hydraulic products are only repaired by local service agents. We have service/repair agents in all parts of the UK.

DO NOT RETURN THE LIFTS TO US. Please telephone 01284 757500 to obtain the address and 'phone number of your local agent. If the lift is under guarantee, please contact your dealer.

De-commissioning: If - and when - the lift becomes completely unserviceable, draw off the oil into an approved container and dispose of the lift and the oil according to local regulations.



Parts support is available for this product. To obtain a parts listing and/or a diagram please log on to: www.sealey.co.uk, email: sales@sealey.co.uk or phone: 01284 757500



Environmental Protection.

Recycle unwanted materials instead of disposing of them as waste. All tools, accessories and packaging should be sorted, taken to a recycle centre and disposed of in a manner which is compatible with the environment.

NOTE: It is our policy to continually improve products and as such we reserve the right to alter data, specifications and component parts without prior notice.

IMPORTANT: No liability is accepted for incorrect use of this product.

WARRANTY: Guarantee is 12 months from purchase date, proof of which will be required for any claim.

INFORMATION: For a copy of our latest catalogue and promotions call us on 01284 757525 and leave your full name and address, including postcode.



Sole UK Distributor, Sealey Group,
Kempson Way, Suffolk Business Park,
Bury St. Edmunds, Suffolk,
IP32 7AR

 01284 757500

 www.sealey.co.uk

 01284 703534

 sales@sealey.co.uk