

Thank you for purchasing a Sealey product. Manufactured to a high standard this product will, if used according to these instructions and properly maintained, give you years of trouble free performance.



IMPORTANT: PLEASE READ THESE INSTRUCTIONS CAREFULLY. NOTE THE SAFE OPERATIONAL REQUIREMENTS, WARNINGS & CAUTIONS. USE THE PRODUCT CORRECTLY AND WITH CARE FOR THE PURPOSE FOR WHICH IT IS INTENDED. FAILURE TO DO SO MAY CAUSE DAMAGE AND/OR PERSONAL INJURY AND WILL INVALIDATE THE WARRANTY. PLEASE KEEP INSTRUCTIONS SAFE FOR FUTURE USE.

1. SAFETY INSTRUCTIONS

1.1 GENERAL SAFETY

- ❑ **WARNING!** Ensure Health & Safety, local authority, and general workshop practice regulations are adhered to when using this equipment.
- ✓ Maintain the calibration rig in good condition.
- ✓ Replace or repair damaged parts. Use genuine parts only. Non-authorized parts may be dangerous and will invalidate the warranty.
- ✓ Locate the calibration rig in a suitable working area, keep area clean and tidy and free from unrelated materials.
- ✓ Keep the calibration rig clean to ensure accurate performance.
- x **DO NOT** use outside in damp or wet weather conditions.
- x **DO NOT** allow untrained persons to operate the calibration rig.
- x **DO NOT** leave the calibration rig unattended.
- ❑ **WARNING!** The warnings, cautions and instructions contained within this document cannot cover all possible conditions and situations that may occur. It must be understood that common sense and caution are factors which cannot be built into this product, but must be applied by the operator.

1.2 LASER SAFETY



The MS070 utilises a Class 2M laser that emits low levels of visible radiation light (i.e. wavelengths between 630 and 640 nanometres) which are safe for the skin but not inherently safe for the eyes. The Class 2M emission limit is set at the maximum level for which eye protection is normally afforded by natural aversion responses to bright light. Accidental eye exposure is therefore normally safe, although the natural aversion response can be overridden by deliberately staring into the beam, and can also be influenced by the use of alcohol or drugs.

- ❑ **WARNING!** Do not look or stare into the laser beam as permanent eye damage could result.
- x **DO NOT** direct the laser beam at any person's (or animal's) eyes as eye damage could result. If the beam is obstructed by a person during use, release the contact switch immediately.
- x **DO NOT** use the equipment while under the influence of alcohol, drugs or whilst on medication.
- ✓ Be aware that reflections of the laser beam from mirrors or other shiny surfaces can be as hazardous as direct eye exposure.

2. INTRODUCTION

Used to check and adjust the alignment of the lasers on Model No. MS070 Motorcycle Wheel Alignment Tool. This unit will allow workshops to check and adjust in-house.

3. SET-UP

- 3.1 **Rig set up:** The twin laser units as seen in fig.1 need to be clamped either side of the calibration rig as shown in fig.2.
 - 3.1.1 Position the left hand laser unit with the rod attached on the left hand side of the rig and insert the rod through the hole in the rig. Slide the right hand laser unit onto the rod and up to the other side of the rig, followed by the spring and clamp unit.
 - 3.1.2 Ensure that the shouldered fixing on the side of the left hand laser from which the rod emerges passes into the hole in the side of the rig so that both laser units lay completely flush either side of the calibration rig.

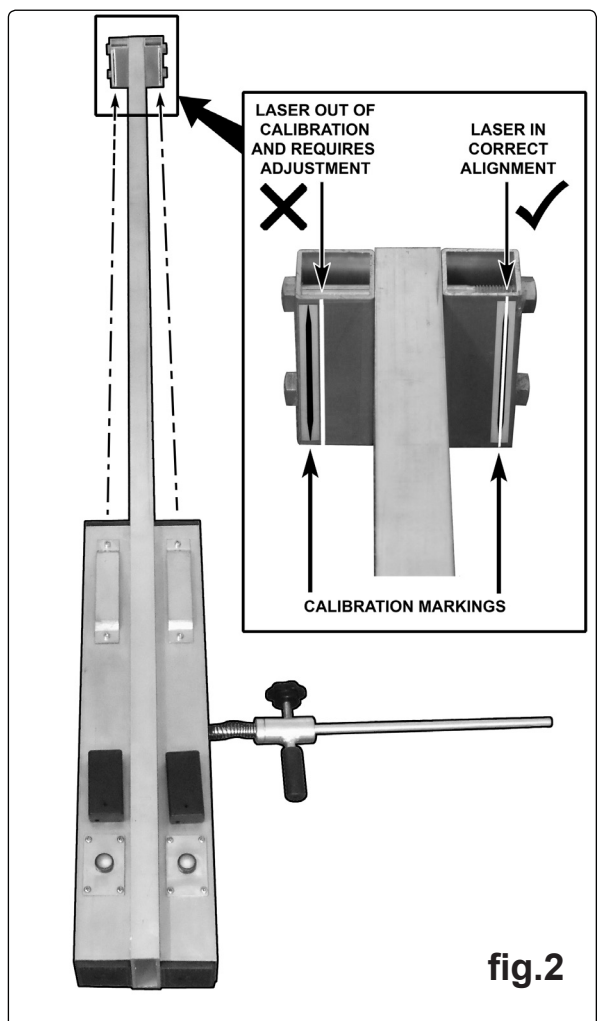
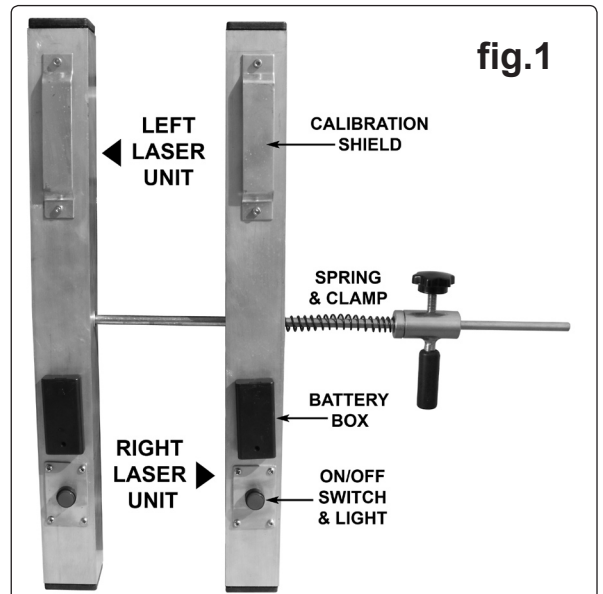

- 3.1.3 Firmly clamp the assembly together.
- 3.1.4 Switch on both lasers and observe the position of the projected beams in relation to the calibration marks at the head of the rig. See the inset diagram in fig.2. If either of the beams are out of alignment they will have to be adjusted as described in the next section.
- 3.2 **Calibrating the lasers:** Firstly, remove the calibration shield from the laser that needs adjusting (see fig.3) by undoing the two socket cap screws that hold the shield in place using a 3mm hex key.
- 3.2.1 Using the 3mm hex key loosen the laser pivot point just enough to allow the laser to pivot within the laser casing.
- 3.2.2 Loosen the laser adjustment point and, by sliding the screw head, move the laser in very small increments until the projected beam is dead on the calibration marking on the rig head. If the beam needs to move to the right, slide the screw head to the left and vice versa.
- 3.2.3 Tighten the laser pivot point first.
- 3.2.4 Carefully tighten the laser adjustment point keeping an eye on the beam to ensure that the calibration does not change.
- 3.2.5 Fix the shield back in place and tighten the fixings.
- 3.2.6 Remove the laser units from the rig.

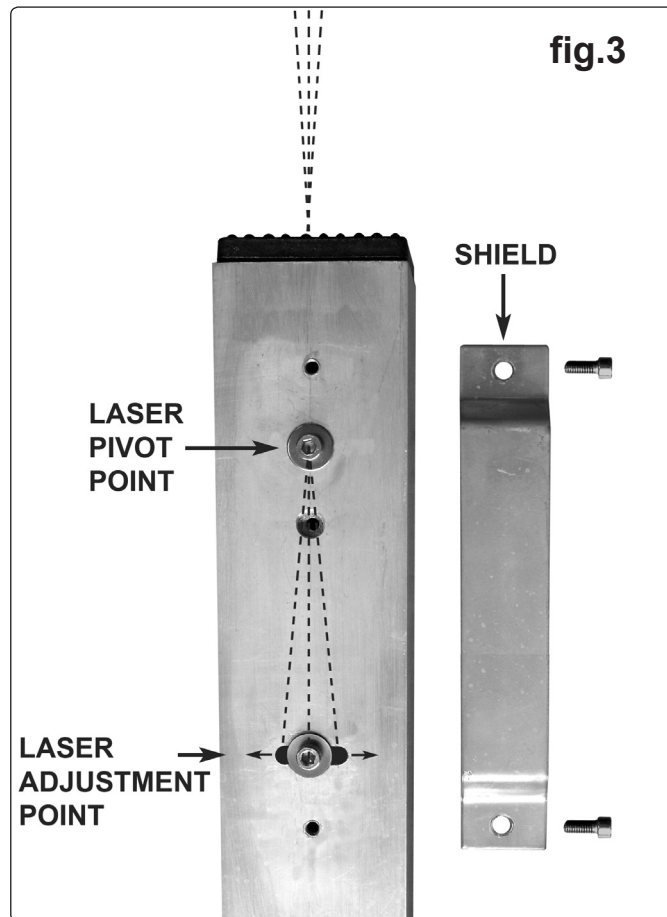

Parts support is available for this product. To obtain a parts listing and/or diagram, please log on to www.sealey.co.uk, email sales@sealey.co.uk or phone 01284 757500.

Environmental Protection.



Recycle unwanted materials instead of disposing of them as waste. All tools, accessories and packaging should be sorted, taken to a recycle centre and disposed of in a manner which is compatible with the environment.

When the product is no longer required, it must be disposed of in an environmentally protective way. Contact your local solid waste authority for recycling information.

NOTE: It is our policy to continually improve products and as such we reserve the right to alter data, specifications and component parts without prior notice.

IMPORTANT: No liability is accepted for incorrect use of this product.

WARRANTY: Guarantee is 12 months from purchase date, proof of which will be required for any claim.

INFORMATION: For a copy of our latest catalogue and promotions call us on 01284 757525 and leave your full name and address, including postcode.



Sole UK Distributor, Sealey Group,
Kempson Way, Suffolk Business
Park, Bury St. Edmunds, Suffolk,
IP32 7AR



01284 757500



01284 703534



www.sealey.co.uk



sales@sealey.co.uk