

Thank you for purchasing a Sealey Product. Manufactured to a high standard this product will, if used according to these instructions and properly maintained, give you years of trouble free performance.



IMPORTANT: PLEASE READ THESE INSTRUCTIONS CAREFULLY. NOTE THE SAFE OPERATIONAL REQUIREMENTS, WARNINGS AND CAUTIONS. USE THIS PRODUCT CORRECTLY AND WITH CARE FOR THE PURPOSE FOR WHICH IT IS INTENDED. FAILURE TO DO SO MAY CAUSE DAMAGE AND/OR PERSONAL INJURY AND WILL INVALIDATE THE WARRANTY. PLEASE KEEP INSTRUCTIONS SAFE FOR FUTURE USE.

1. SAFETY INSTRUCTIONS

- ❑ **WARNING!** Ensure Health & Safety, local authority, and general workshop practice regulations are adhered to when using this equipment.
- ✓ Familiarise yourself with the specific applications and limitations of the shelter, as well as any potential hazards.
- ✗ **DO NOT** use the shelter for any purpose other than that for which it is designed.
- ✓ Maintain correct balance and footing. Ensure the floor/ground is not slippery and wear non-slip shoes.
- ✓ Locate the shelter on level and solid ground, preferably concrete. If placed on tarmac/adam or grass ensure that the motorcycle is adequately supported before using the shelter.
- ✓ Locate the shelter in a suitable area. Keep the area clean and tidy and free from unrelated materials, and ensure that there is adequate lighting.
- ✗ **DO NOT** use if any parts are damaged, as this may cause failure and/or personal injury.
- ✗ **DO NOT** use the shelter when you are tired or under the influence of alcohol, drugs or intoxicating medication.
- ✓ Keep children and unauthorised persons away from the working area.
- ✓ Ensure that the shelter is the correct size for the motorcycle.
- ✓ Keep the shelter clean for best and safest performance.

2. INTRODUCTION

Made with 600D polyester Oxford waterproof material, designed never to touch the motorcycle and protect against damaging UV rays. Covered ventilation on both sides of the shelter allows for air flow, to help reduce condensation. Fitted with a locking mechanism with eyelet for use with padlock (not included). Supplied with soft ground anchors. Three sizes available to fit most motorcycles, ATVs, trikes or even ride-on lawn mowers.

Sizes (mm)	Length	Width	Height
MS065:	2700	1050	1550
MS066:	3450	1370	1900
MS067:	3450	1880	1900

3. INSTRUCTIONS

3.1. Preparation.

- 3.1.1. Check the contents against the parts list/diagram, if any parts are missing, contact your Sealey dealer.

3.2. Assembling the frame.

- 3.2.1. Lay out frame assembly (A) to the right and frame assembly (B) to the left, with the shortest tubes (G) pointing away and the other ribs fanned outwards.
- 3.2.2. Connect tubes (H) between tubes (G) and the first ribs with the angled ends at the rib end. Secure using 1 (J) bolt, 2 (K) washers and 1 (L) nut at each end.
- 3.2.3. Lift the frames one at a time and push fit connector (D) into the tubes (G).
- 3.2.4. Push fit connecting frames (C) to each pair of ribs except for the last one, leave this free to fit the cover later (5 in total).
- 3.2.5. Fit the lock bar (O) by removing the bottom bolts on the B frame, attaching the lock bar (O), then re-fitting the bolts. Slide lock ring tube (I) over tube (E) on the same side as the lock bar.

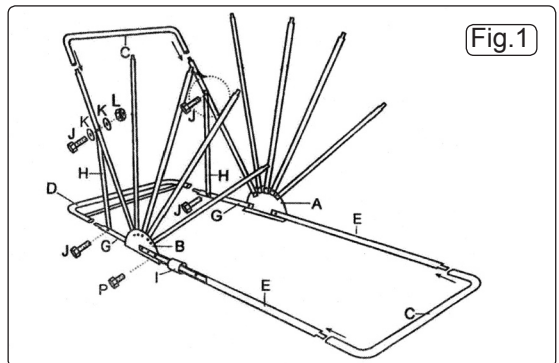
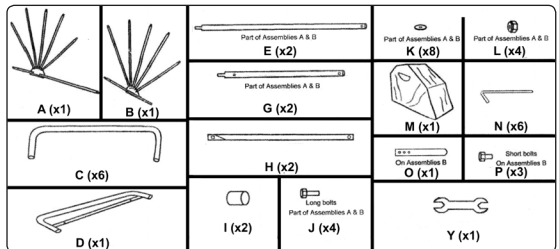

3.3. Fitting the Cover (fig.2).

- 3.3.1. Fit the cover with the frame in the open position.
- 3.3.2. Insert tubes (E) into 2 side sleeves and last connector (C) into the middle sleeve at one end of the cover and then push fit connector (C) into the ends of the tubes (E).
- 3.3.3. Pull cover over the rest of the frame and secure other end to connector (D) by wrapping the flap around it and securing it with touch fastener.
- 3.3.4. Lift connector (C) at the other end and enter under the cover. Move each rib into position and secure to the cover by wrapping the flaps around them and securing with touch fasteners until all the ribs are connected except the first one connected to the H tubes - this is not secured to the cover.

3.4. Securing the Frame.

- 3.4.1. It is recommended that the frame is secured to the ground using weights or bolted down as appropriate. Secure using pre-drilled holes in frames A and B and at connector D.

3.5. Use.

- 3.5.1. To use the shelter, simply open it (fig.3) and then manoeuvre the motorcycle into the shelter. If engine and exhausts are hot - ensure that they do not come into contact with the cover. Ensure motorcycle is correctly supported before leaving it (fig.4). Pull cover over the motorcycle and engage lock tube over lock bar, and secure with a padlock (not supplied) if required (fig.5).

3.6. Folding Down.

- 3.6.1. If the Shelter needs to be folded down for removal, undo any bolts securing the frame to the ground, then undo the nuts and bolts securing the tubes (H) to the tubes (G) and ribs. Remove tubes (H) and collapse the shelter.

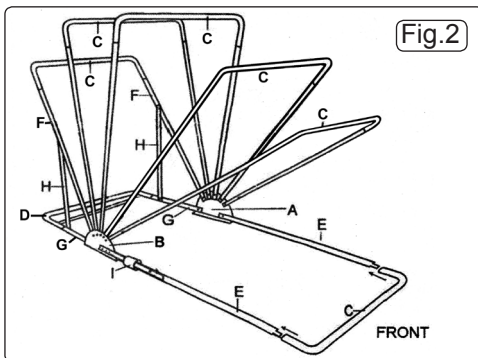

NOTE: It is our policy to continually improve products and as such we reserve the right to alter data, specifications and component parts without prior notice.

IMPORTANT: No liability is accepted for incorrect use of this product.

WARRANTY: Guarantee is 12 months from purchase date, proof of which will be required for any claim.

INFORMATION: For a copy of our latest catalogue and promotions call us on 01284 757525 and leave your full name and address, including postcode.



Professional TOOLS

Sole UK Distributor, Sealey Group,
Kempson Way, Suffolk Business Park,
Bury St. Edmunds, Suffolk,
IP32 7AR



www.sealey.co.uk
sales@sealey.co.uk