

Thank you for purchasing a Sealey product. Manufactured to a high standard this product will, if used according to these instructions and properly maintained, give you years of trouble free performance.



IMPORTANT: PLEASE READ THESE INSTRUCTIONS CAREFULLY. NOTE THE SAFE OPERATIONAL REQUIREMENTS, WARNINGS, AND CAUTIONS. USE THIS PRODUCT CORRECTLY, AND WITH CARE FOR THE PURPOSE FOR WHICH IT IS INTENDED. FAILURE TO DO SO MAY CAUSE DAMAGE, OR PERSONAL INJURY, AND WILL INVALIDATE THE WARRANTY.

1. ELECTRICAL SAFETY

1.1. PLUG & MAINS POWER SUPPLY

WARNING! It is the owner's responsibility to read, understand and comply with the following:

You must check all electrical equipment and appliances to ensure that they are safe before using. You must inspect power supply leads, plugs and all electrical connections for wear and damage. You must ensure that the risk of electric shock is minimised by the installation of appropriate safety devices. An RCCB (Residual Current Circuit Breaker) should be incorporated in the main distribution board. We also recommend that an RCD (Residual Current Device) is used with all electrical products. It is particularly important to use an RCD together with portable products that are plugged into an electrical supply not protected by an RCCB. If in doubt consult a qualified electrician. You may obtain a Residual Current Device by contacting your Sealey dealer. **You must** also read and understand the following instructions concerning electrical safety. **NOTE: 110 volt lights are usually operated by connecting to a transformer or a generator. Check to ensure all supply equipment is compatible with the rating of the light.**

- 1.1.1. The **Electricity At Work Act 1989** requires all portable electrical appliances, if used on business premises, to be tested by a qualified electrician, using a Portable Appliance Tester (PAT), at least once a year.
- 1.1.2. The **Health & Safety at Work Act 1974** makes owners of electrical appliances responsible for the safe condition of the appliance and the safety of the appliance operator. **If in any doubt about electrical safety, contact a qualified electrician.**
- 1.1.3. Ensure the insulation on all cables and the product itself is safe before connecting to the power supply. See 1.1.1. & 1.1.2. above and use a Portable Appliance Tester (PAT).
- 1.1.4. Ensure that cables are always protected against short circuit and overload.
- 1.1.5. Regularly inspect power supply, leads, plugs and all electrical connections for wear and damage and especially power connections to ensure that none is loose.
- 1.1.6. **Important:** Ensure the voltage marked on the product is the same as the electrical power supply to be used and check that plugs are fitted with the correct capacity fuse.
- 1.1.7. **Important:** For use of a 110 volt lights - ensure that the 110 volt transformer or generator is adequately rated.
- 1.1.8. **DO NOT** pull or carry the appliance by the power cable.
- 1.1.9. **DO NOT** pull plugs from sockets by the power cable.
- 1.1.10. **DO NOT** use worn or damaged leads, plugs or connections. Immediately replace or have repaired by a qualified electrician. A U.K. 3 pin 110 volt plug with ASTA/BS approval is fitted. In case of damage, cut off and fit a new plug according to the following instructions (discard old plug safely). (UK only - see diagrams below).

Ensure the unit is correctly earthed via a three-pin plug. FOR 110 VOLT PLUG SEE FIG.2 BELOW.

- a) **Connect the GREEN/YELLOW earth wire to the earth terminal 'E'.**
- b) **Connect the BROWN live wire to live terminal 'L'.**
- c) **Connect the BLUE neutral wire to the neutral terminal 'N'.**
- d) **After wiring, check that there are no bare wires, that all wires have been correctly connected, that the cable external insulation extends beyond the cable restraint and that the restraint is tight.**

- 1.1.11. **Cable extension reels.** When a cable extension reel is used it should be fully unwound before connection. A cable reel with an RCD fitted is recommended since any product which is plugged into the cable reel will be protected. The section of the cores of the cable is important and should be at least 1.5mm², but to be absolutely sure that the capacity of the cable reel is suitable for this product and for others that may be used in the other output sockets, we recommend the use of 2.5mm² section cable.

1.2. LIGHT WIRING

WARNING! Ensure all cables are disconnected from the power supply before attempting following.

Should you need to re-wire the cable into the lamp, proceed as follows: Remove back cover of terminal box, located at the rear of the lamp, to expose the connection block and wires, see fig.1. Wire in accordance with 1.1.10 (a to d) above, check that the weather proofing seal is correctly located in the back cover recess and then replace the back cover. If in any doubt contact a qualified electrician.

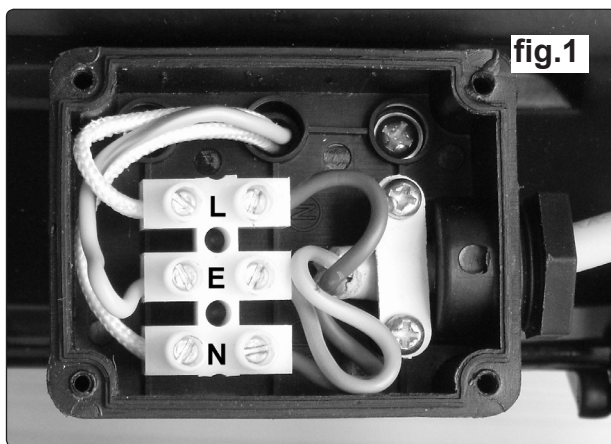

fig.1

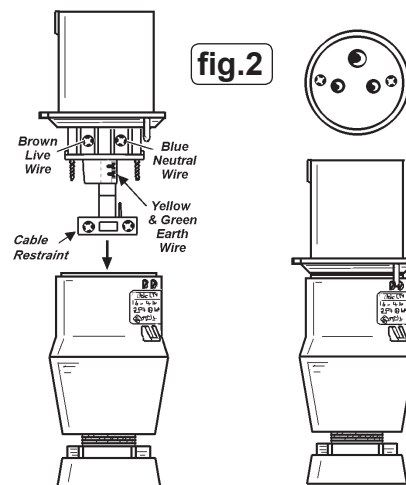

fig.2

2. GENERAL SAFETY

- WARNING!** Disconnect light from the power supply before changing accessories, servicing or performing any maintenance.
- ✓ Maintain the light in good condition. Repairs must only be undertaken by a qualified electrician (use an authorised service agent).
- ✓ Replace or repair damaged parts. Unauthorised parts may be dangerous and will invalidate the warranty.
- ✓ Keep a minimum distance of 1 metre from the front of light to the surface which is to be illuminated. Floodlights give off intense heat.
- ✓ Locate the light in an adequate area for its function, keep area clean and tidy and free from unrelated materials.

- ✓ If you use an extension lead **the cable must be fully unwound from the drum.**
- ✓ The light is weather proof and may be used out doors. Ensure any extensions and plugs are weatherproof.
- ❑ **DANGER! DO NOT direct the light into a person's eyes. All models have a very intense light output which, if incorrectly used, could cause eye damage.**
- ✗ **DO NOT** touch the light when operating. Allow to cool before touching, light operates at high temperature.
- ✗ **DO NOT** handle halogen bulbs as the natural oil from your fingers will shorten the bulb life. Handle only with a soft dry cloth.
- ✗ **DO NOT** use the light without the front glass shield. Avoid touching the glass shield as handling may reduce its serviceable life and cause the glass to crack.
- ✗ **DO NOT** use the light without the weather seals intact.
- ✗ **DO NOT** use the light near flammable, combustible or explosive liquids, solids, gases or equipment.
- ✓ When not in use, switch off the light and disconnect from the power supply. Ensure that the unit is cool and dry and then store in a safe, dry, childproof area.

3. GENERAL INSTRUCTIONS

- ❑ **WARNING! Ensure the light is disconnected from the mains power supply before attempting any of the following.**

3.1. ASSEMBLY

- 3.1.1. Slide the high end of the stand into the black clamp as indicated in fig.3. Align the threaded insert in the stand with the hole in the black clamp and screw in the fixing knob ensuring that the contoured washer on the threaded part fits the curvature of the clamp. Adjust the angle of the floodlight as required and tighten the knob to grip the stand.

3.2. GENERAL

Use only original Sealey parts for repair or replacement. Repairs must only be undertaken by a qualified electrician.

Clean the light with a dry, dust-free cloth. **DO NOT** use solvents or abrasives to clean the light.

Avoid touching the glass shield (fig.5.2) as handling may reduce service life and cause the glass to crack. If necessary clean the shield (when cold) with alcohol and a soft cloth. If the glass is damaged, replace it immediately. Use genuine Sealey replacement glass. **DO NOT** use other glass and **DO NOT** use the light without the glass shield.

Although weather proof, the light must not be stored wet. Should the unit become wet, unplug from mains and wipe dry before storing.

DO NOT use the light without the weather seal intact.

3.3. BULB CHANGING

- ❑ **WARNING! Disconnect the light from the power supply and allow to cool before attempting to touch the unit.**

DO NOT touch the new halogen bulb as the natural oil from your fingers will shorten the bulb life. Handle with a dry, clean cloth only.

- 3.3.1. Loosen the screw on the top of the front cover (fig.5) and undo, allowing the front cover to open. Check to ensure that the screw is retained in the front cover tab (3) by the washer.
- 3.3.2. Remove the old bulb and discard. Hold the new bulb (1) in a clean cloth and insert it (always use the correctly rated bulb).
- 3.3.3. Check that the weather seal is correctly located in the rim (4) and the washer is on the securing screw. Close the front cover. Seal by tightening the securing screw.

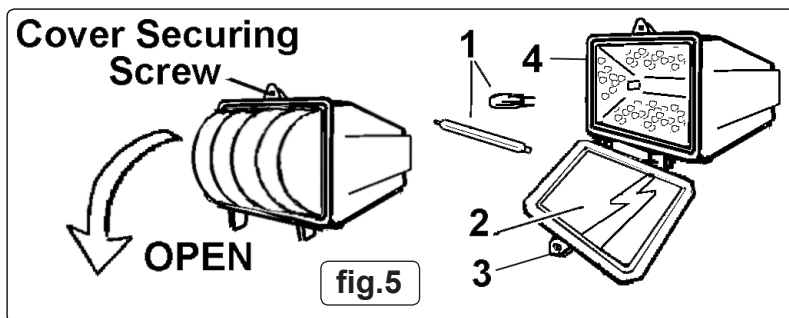
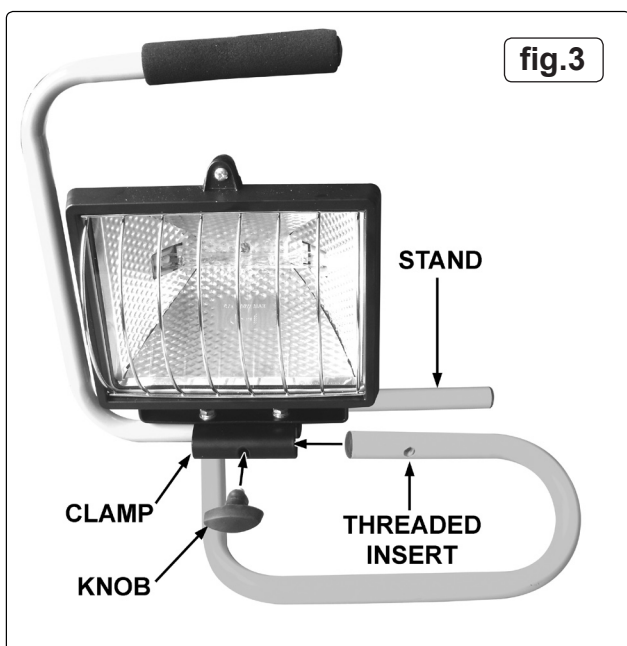

Environmental Protection.

Recycle unwanted materials instead of disposing of them as waste. All tools, accessories and packaging should be sorted, taken to a recycle centre and disposed of in a manner which is compatible with the environment.

When the product is no longer required, it must be disposed of in an environmentally protective way. Contact your local solid waste authority for recycling information.

NOTE: It is our policy to continually improve products and as such we reserve the right to alter data, specifications and component parts without prior notice.

IMPORTANT: No liability is accepted for incorrect use of this product.

WARRANTY: Guarantee is 12 months from purchase date, proof of which will be required for any claim.

INFORMATION: For a copy of our latest catalogue and promotions call us on 01284 757525 and leave your full name and address, including postcode.



Sole UK Distributor, Sealey Group,
Kempson Way, Suffolk Business Park,
Bury St. Edmunds, Suffolk,
IP32 7AR

01284 757500

www.sealey.co.uk

01284 703534

sales@sealey.co.uk