

Thank you for purchasing a Sealey product. Manufactured to a high standard this product will, if used according to these instructions and properly maintained, give you years of trouble free performance.

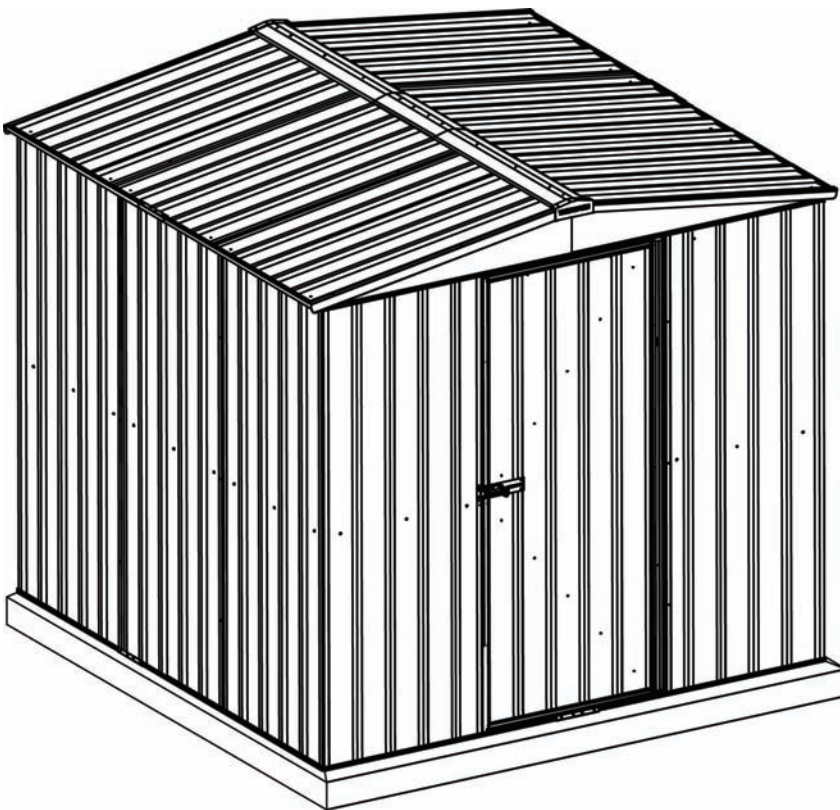

IMPORTANT: PLEASE READ THESE INSTRUCTIONS CAREFULLY. NOTE THE SAFE OPERATIONAL REQUIREMENTS, WARNINGS AND CAUTIONS. USE THE PRODUCT CORRECTLY AND WITH CARE FOR THE PURPOSE FOR WHICH IT IS INTENDED. FAILURE TO DO SO MAY CAUSE DAMAGE AND/OR PERSONAL INJURY AND WILL INVALIDATE THE WARRANTY. PLEASE KEEP INSTRUCTIONS SAFE FOR FUTURE USE.

- WARNING! Ensure Health & Safety, local authority, and general workshop practice regulations are adhered to when building this shed.
 - ✓ Keep the work area clean, uncluttered and ensure there is adequate lighting.
 - ✓ Keep children and unauthorised persons away from the working area.
 - ✗ DO NOT use the shed for any purpose other than that for which it is designed.
 - ✓ Use appropriate safety clothing including eye protection.
- Note! The assembly of this product will require assistance.



Before commencing the assembly, we recommend that you read the instructions thoroughly. Your new shed comes with all the holes pre drilled to make for fast easy assembly. We recommend that you assemble the shed using a trestle table or sawhorses and planks. This will ensure that you are working off the ground and make it easier for you. Assembly is a two person job and should not be attempted in windy conditions.

Step 1: Check all parts against the component list.

Step 2: Assemble the rear wall panels.

Step 3: Assemble the side wall panels.

Step 4: Assemble the roof wall panels.

Step 5: Assemble the front wall panels.

Step 6: Assemble front door.

Step 7: Fit the panels together.

Concrete Slab: It is recommended that your new shed is secured to a concrete slab as per the specifications in this manual.

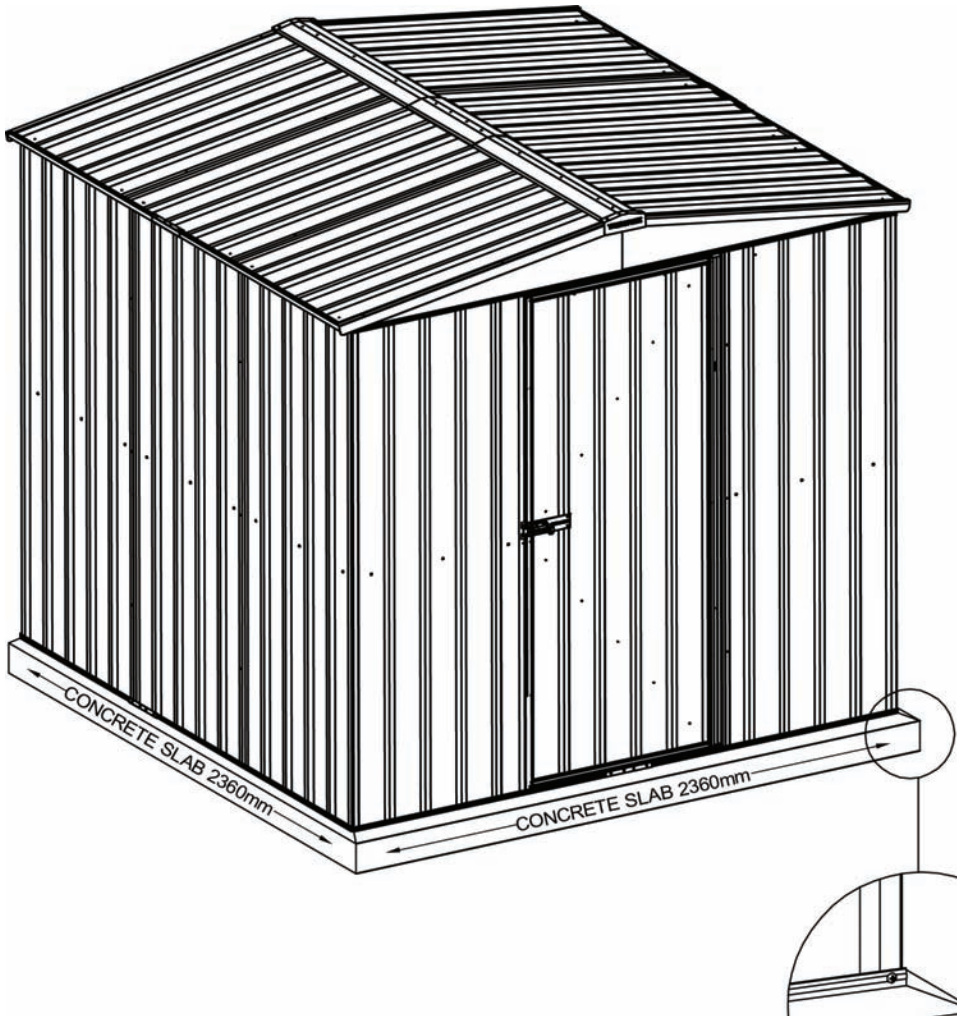

Concrete slab: Please ensure that your site is level. It is recommended that your slab is 100mm thick and you use builders plastic and F52 reinforcing mesh. We recommend that you make your slab 100mm bigger than the base dimensions of your shed. This will allow for a 50mm edge around your shed. We recommend that you slope the 50mm edges downward by 10 mm so that rain water will drain away from your shed.

Tools Required:



Drill



Measuring Tape



Screwdrivers



8mm Masonry Drill Bit



Riveter



Rubber Mallet



Sturdy Ladder (two if possible)



Shifting Spanner



3mm Masonry Drill Bit



Sawhorse



Builders Pencil













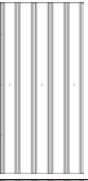
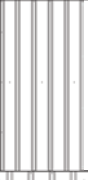
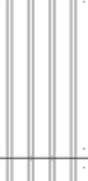



Gloves

























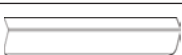

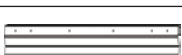
Protective Eyewear







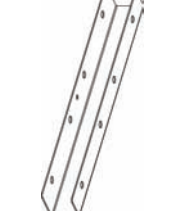





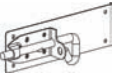

Step 1 : Check all parts against the component list

Lay out all parts with number facing outwards and check off against parts list

Picture	Description	Component	Location	Part No.	QTY	Check
	Sheet	Sheet 1900x770	rear wall side wall	9S	6	
	Sheet	Sheet 1900x770	rear wall side wall	9M	3	
	Sheet	Sheet 1169x770 -left	roof	10L	2	
	Sheet	Sheet 1169x770 -right	roof	10R	2	
	Sheet	Sheet 1169x770-middle	roof	10M	2	
	Sheet	Sheet 1900x735 -left	front	11L	1	
	Sheet	Sheet 1900x735 -right	front	11R	1	
	Door	Sheet 1845x770	door	5R	1	
	Channel	channel 775	front	23A	1	
	Channel	channel 1124	side wall roof	26A	4	
	Channel	channel 1124	side wall roof	26B	4	
	Channel	channel 1124	rear wall	26C	1	
	Channel	channel 1124	rear wall	26D	1	
	Channel	channel 1124	roof	26E	2	
	Channel	channel 1124	roof	26F	2	
	Channel	channel 1124	rear wall	26H	1	

	Channel	channel 1124	rear wall	26I	1	
	Channel	channel 1124	side wall	26J	2	
	Channel	channel 1124	side wall	26K	2	
	Channel	channel 1124	front	26L	1	
	Channel	channel 1124	front	26M	1	
	Channel	channel 1124	front	26N	1	
	Channel	channel 1124	front	26P	1	
	Channel	channel 674	front	33R	1	
	Channel	channel 674	front	33L	1	
	Channel	channel 1098	side wall	34R	3	
	Channel	channel 1098	rear wall	34L	3	
	Channel	channel 1098	side wall	34L	3	
	Channel	channel 1098	rear wall	34L	3	
	Jamb	jamb 1898	front	41A	1	
	Jamb	jamb 1898	front	41B	1	
	Jamb	jamb 775	front	42A	1	
	Lip	lip 1172	roof	52	4	
	Gable cap	Gable cap 1125	roof	60	2	
	Connector	Gable cap connector450	roof	61	1	
	Ridge beam	Ridge beam 1125 zinc	roof	62	2	
	Gable R/H	Gable 1100	roof	63R	2	
	Gable L/H	Gable 1100	roof	63L	2	
	Logo cap	Logo cap	roof	64	2	
	roof brace	roof brace zinc	roof	65	2	
	Ridge beam connector	Ridge beam connector 450mm zinc	roof	67	1	
	Channel connector	Channel connector 188mm		66	11	

FITTINGS PACK

Picture	Component	QTY	Picture	Component	QTY
	Self tapping screws(10mm)	355		Self tapping screws(16mm)	22
	φ 4x10mm Rivet	12		φ 3x10mm Rivet	6
	Pad bolt	1		Keeper	1
	Base bracket	11		5/16" x 19mm Hexagonal bolt	11
	5/16" Hexagonal Nut	11		Mid wall brace bracket	4
	Mid wall channel connector	3		Self tapper safety cover	40
	Channel safety cover (L type)	1		Channel safety cover (R type)	1
	Rawl bolt	11			

In the unlikely event that you find you are missing a part, please contact your Sealey dealer.

Shed Overview

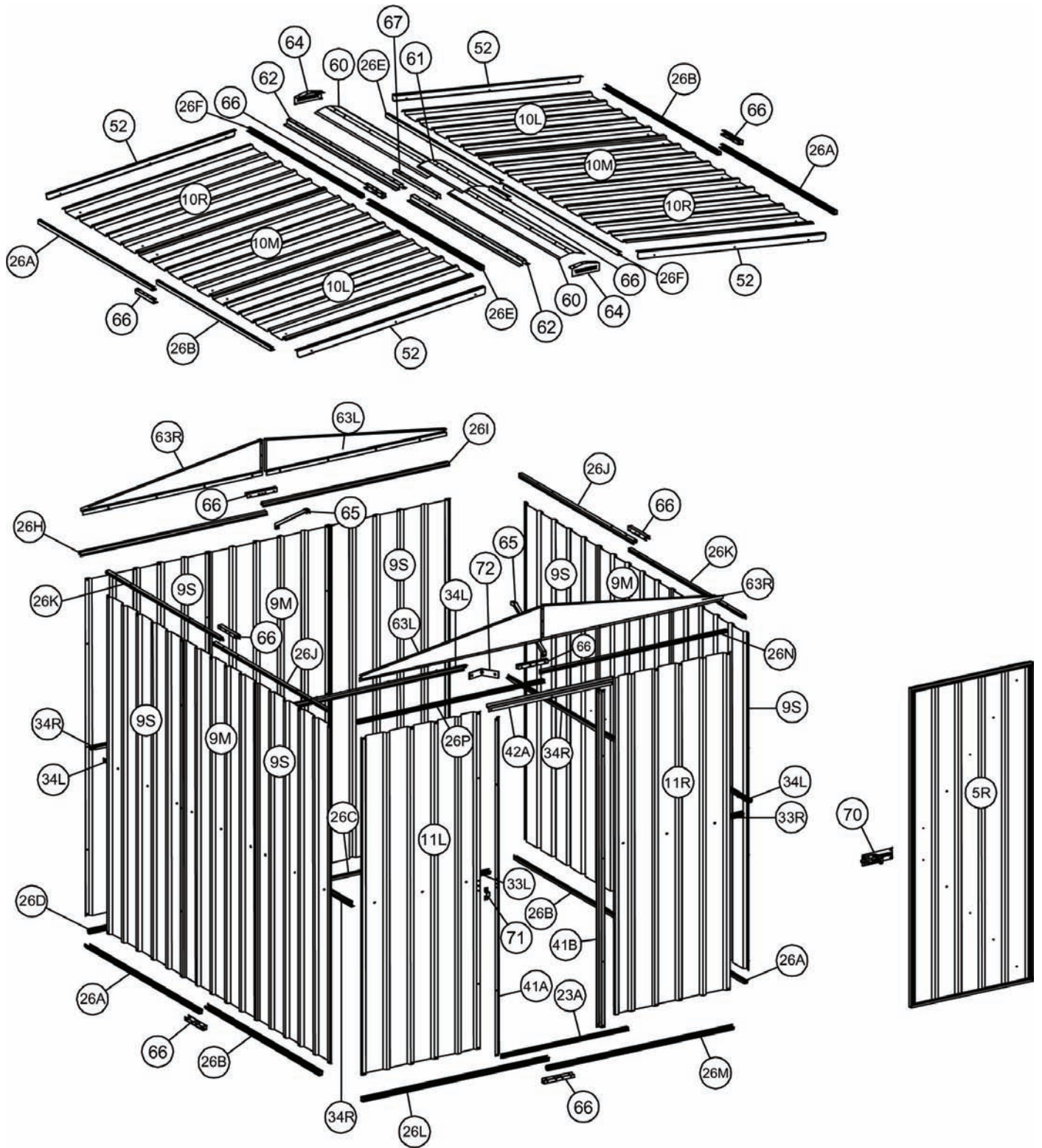

Step 2: Assemble rear wall panels.

You will find it easier to assemble your shed using sawhorses with timber studs attached (timber needs to be the same length as the shed (2M) or alternatively, a trestle table.

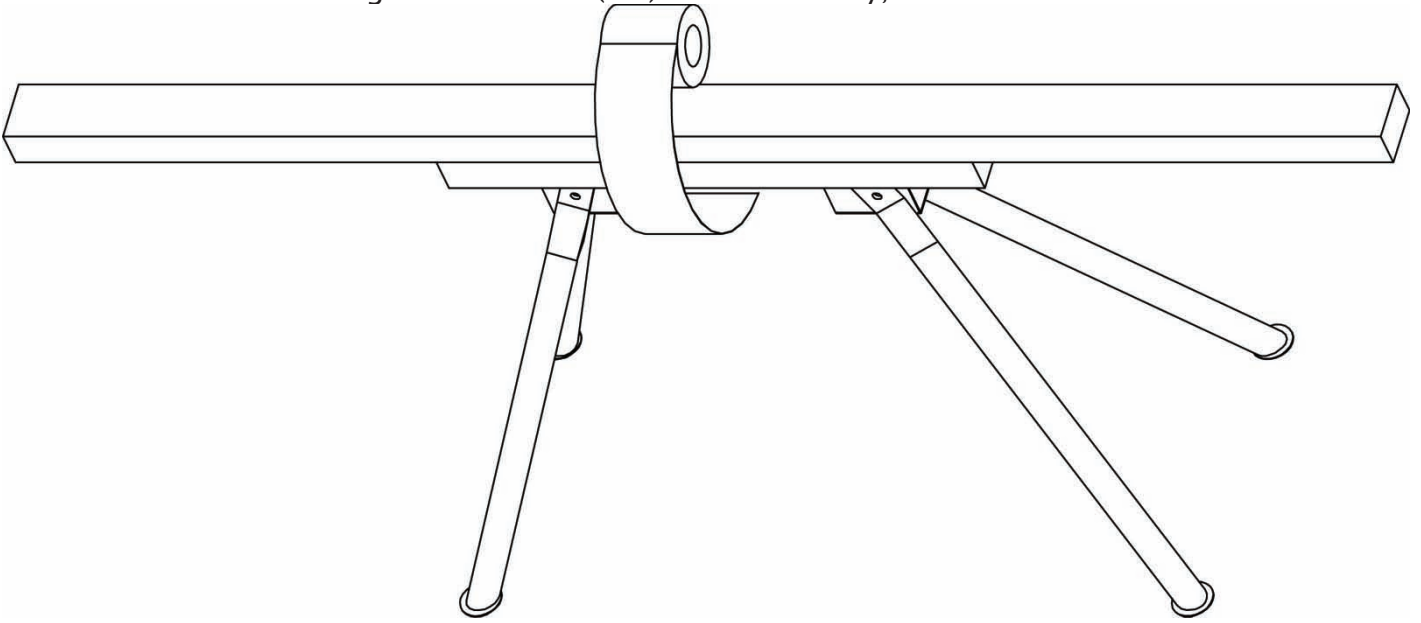

Place 2 x 9S and 9M the sheeting on your work table and join together with the self tapping screws per the diagram.

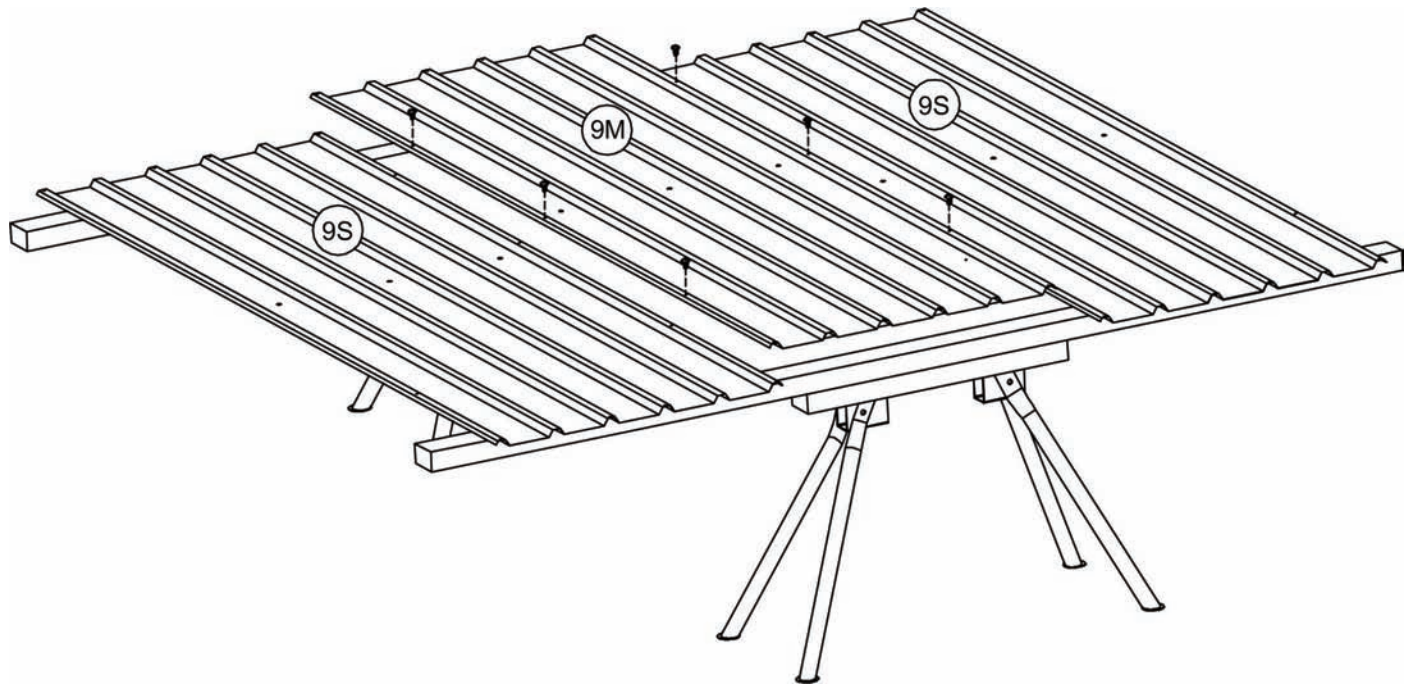

Now fit 26I, 26H top channel and 26C, 26D bottom channel to the sheeting by tapping it in (diagram A) or sliding it in. (Diagram B) Note that the small lip of the channel is always facing out. This is to ensure that rain water can not build up inside your shed. Make sure 26I and 26H are used as top side channels.

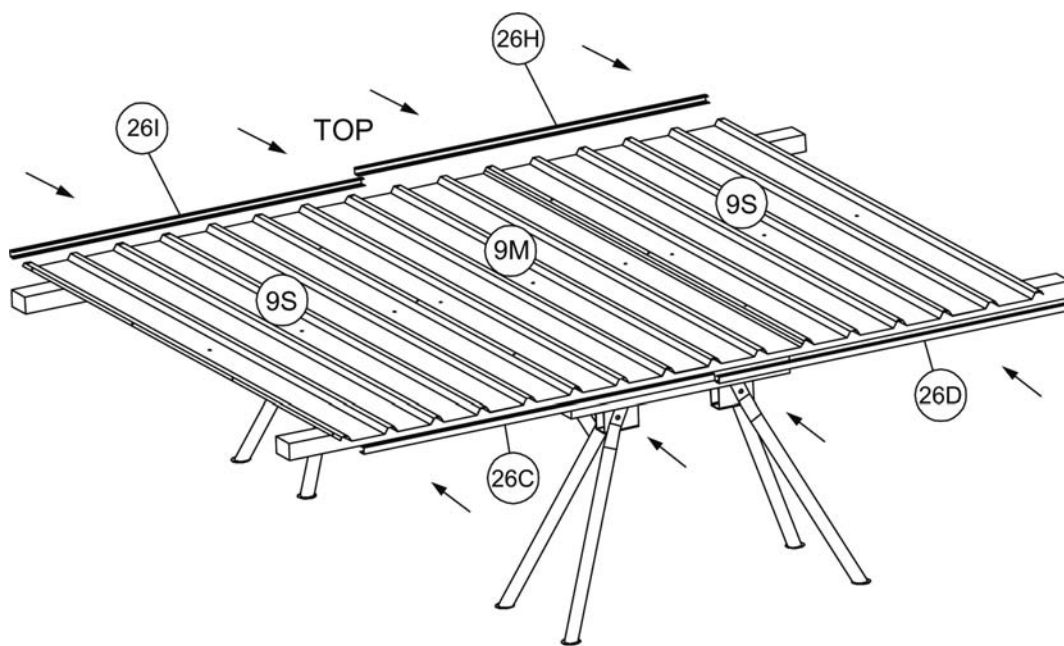

A

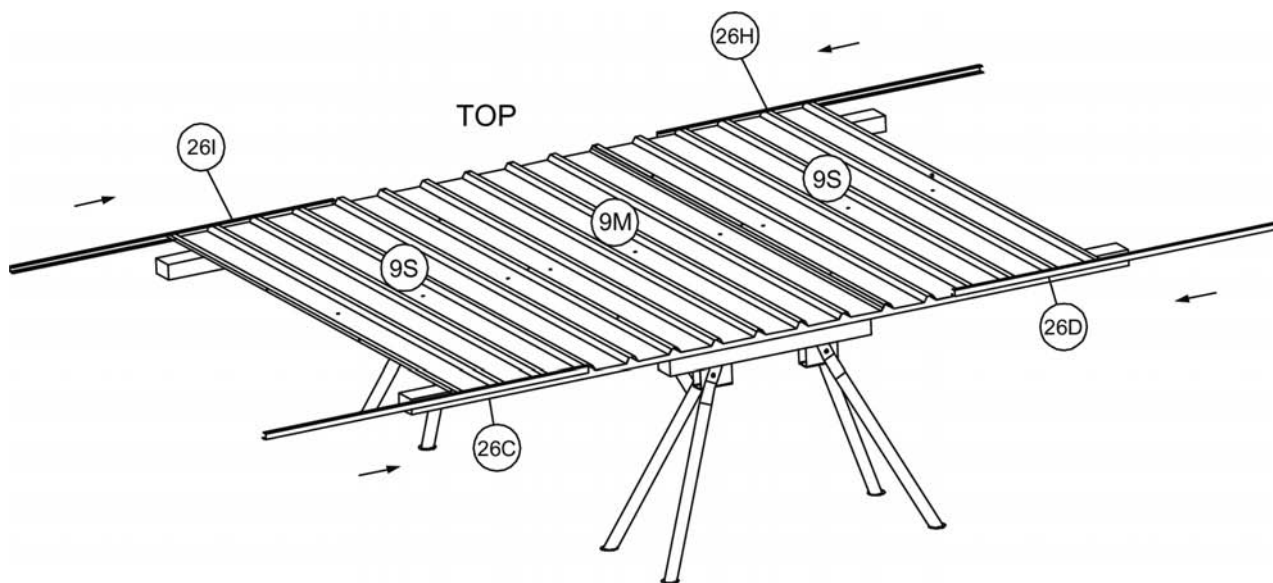

B

Now fix 34R and 34L mid wall channels joint by mid wall channel connector to the sheeting by the self tapping screws. Please note that the groove should face downwards. Fix other channels by the self tapping screws. Apply 66 the channel connectors on top and bottom channels to enhance the strength. (Place a block under the shadowed area when screwing as a support and the screw with cross mark must not be fixed in this stage).

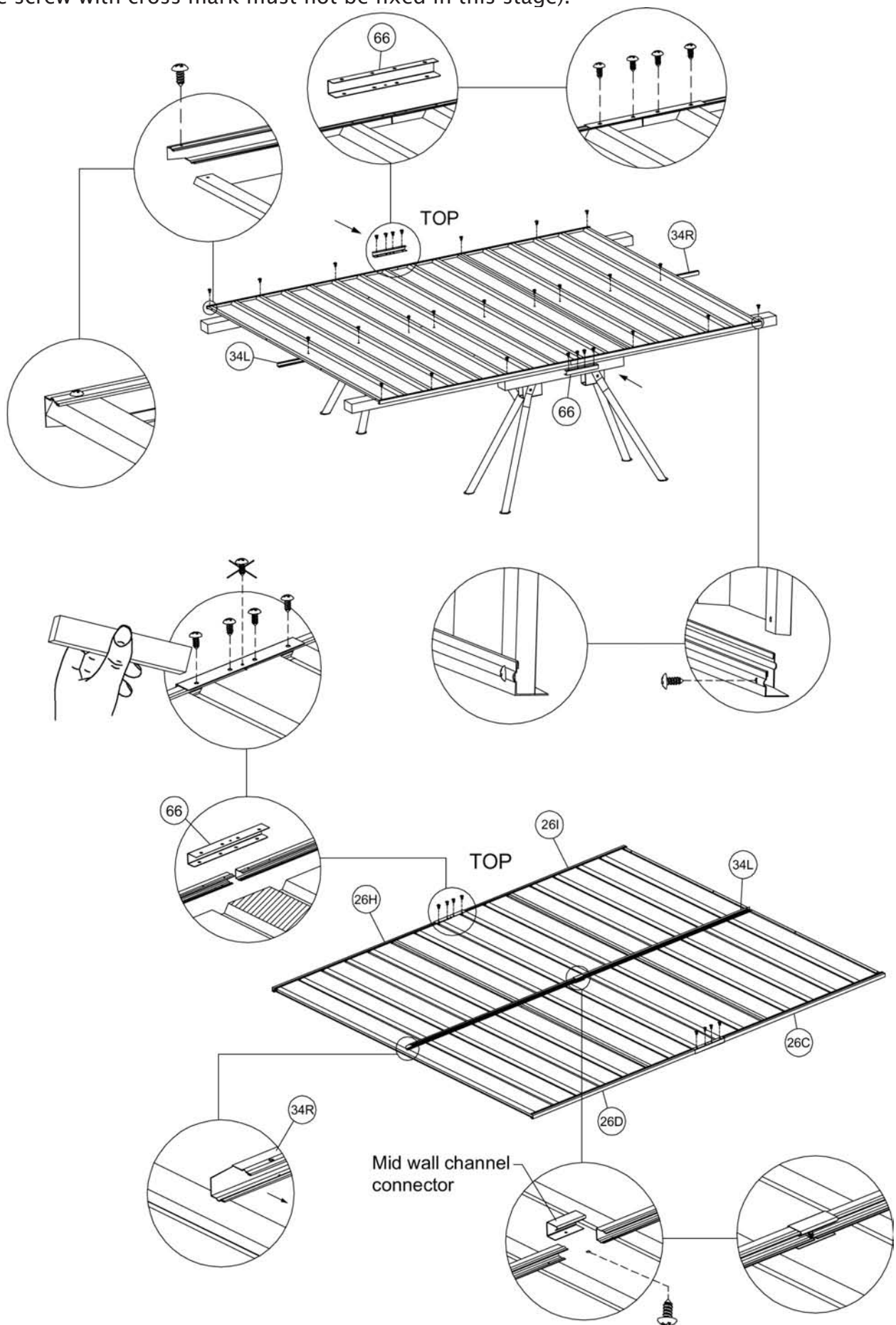

Step 3: Assemble side wall panels.

Place 2 x 9S and 9M the sheeting on your work table and join together with the self tapping screws per the diagram. Now fit 26K, 26J top channel and 26A, 26B bottom channel to the sheeting by tapping it in or sliding it in. Note that the small lip of the channel is always facing out. This is to ensure that rain water can not build up inside your shed. Make sure 26K and 26J are used as top side channels. Now fix 34R and 34L the mid wall channels to the sheeting by the self tapping screws. Please note that the groove should face downwards. Fix other channels by the self tapping screws and enhance the strength by applying 66 the channel connectors.

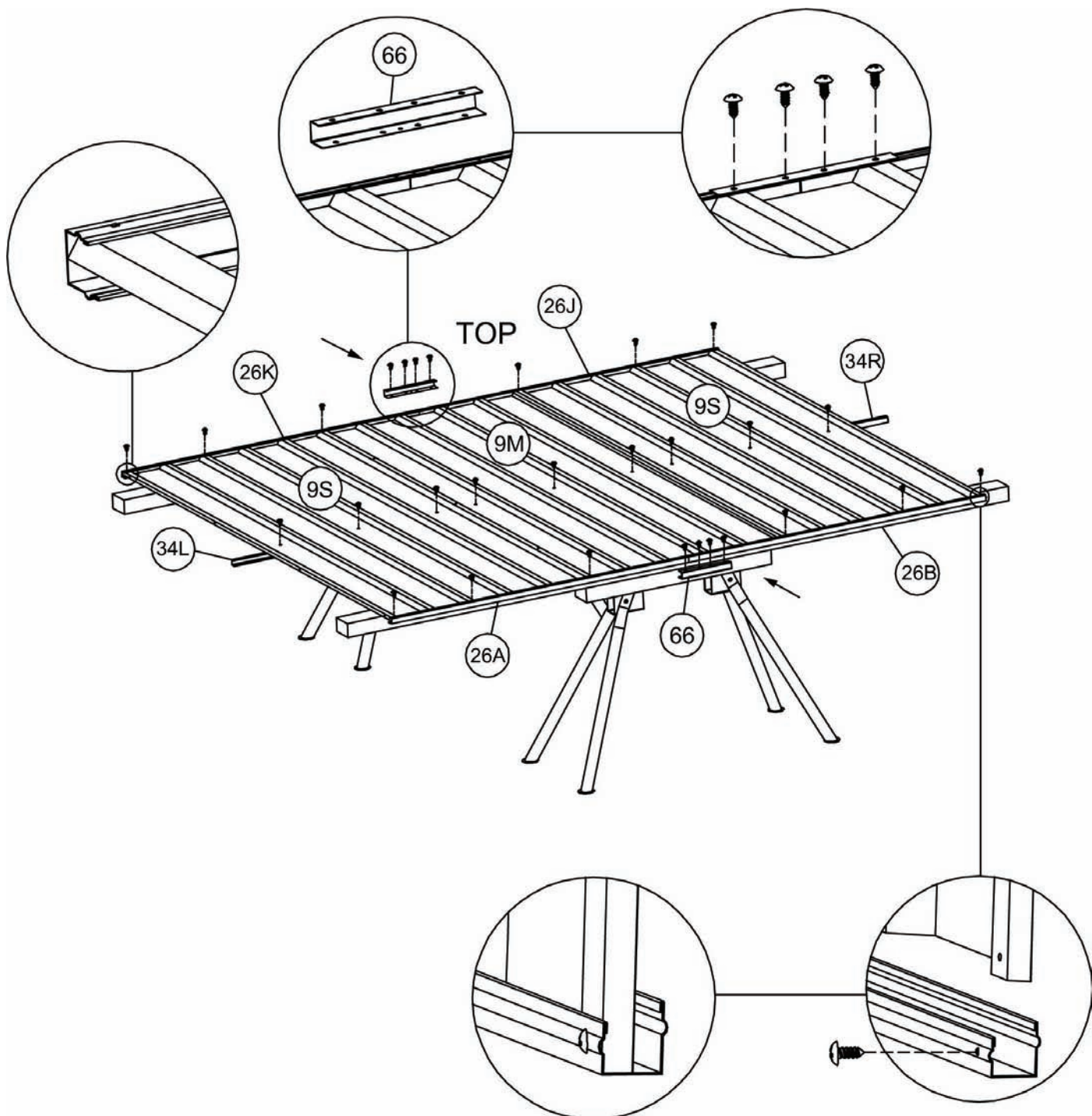

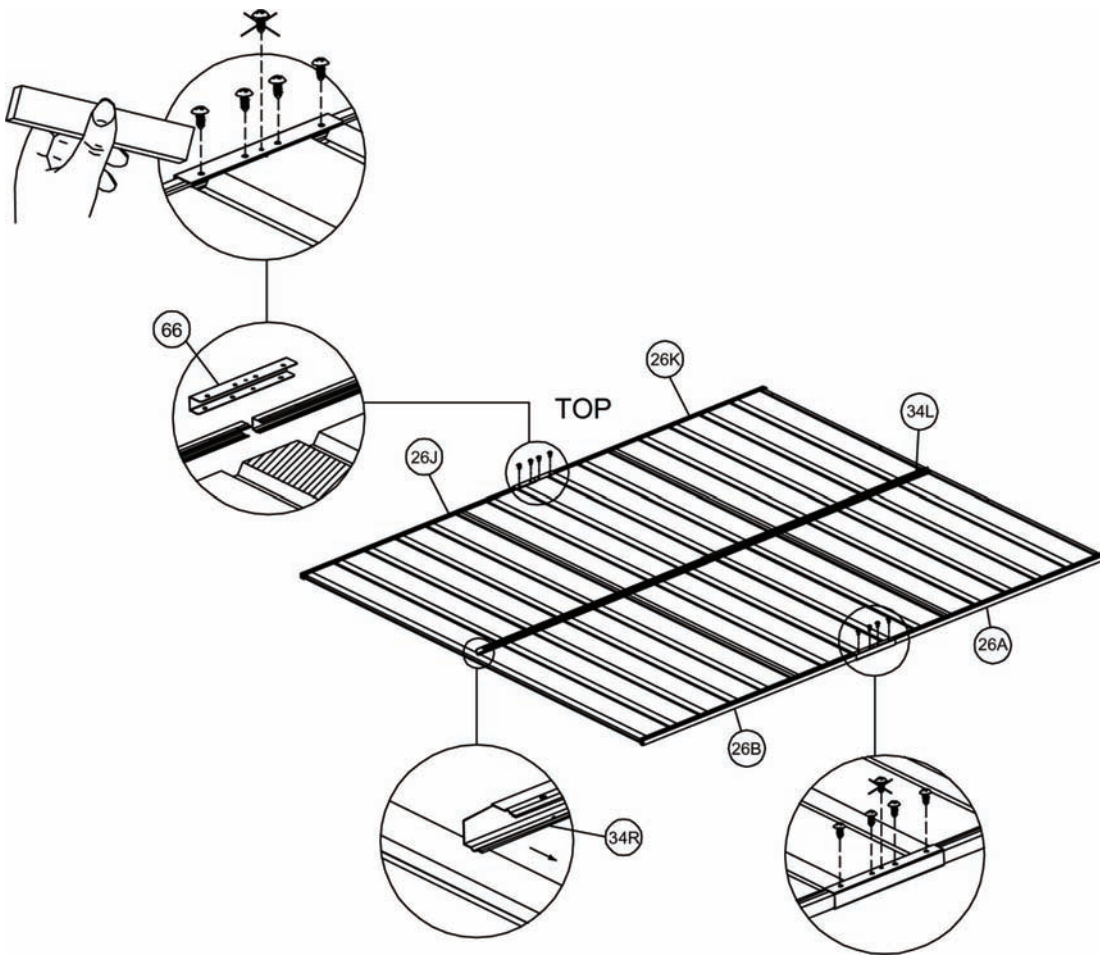

Place a block under the shadowed area when screwing as a support and the screw with cross mark must not be fixed in this stage. Repeat the same steps for the other side wall.

Step 4: Assemble the roof panel.

Place 10R, 10M and 10L the sheeting on your work table and join together with the self tapping screws per the diagram.

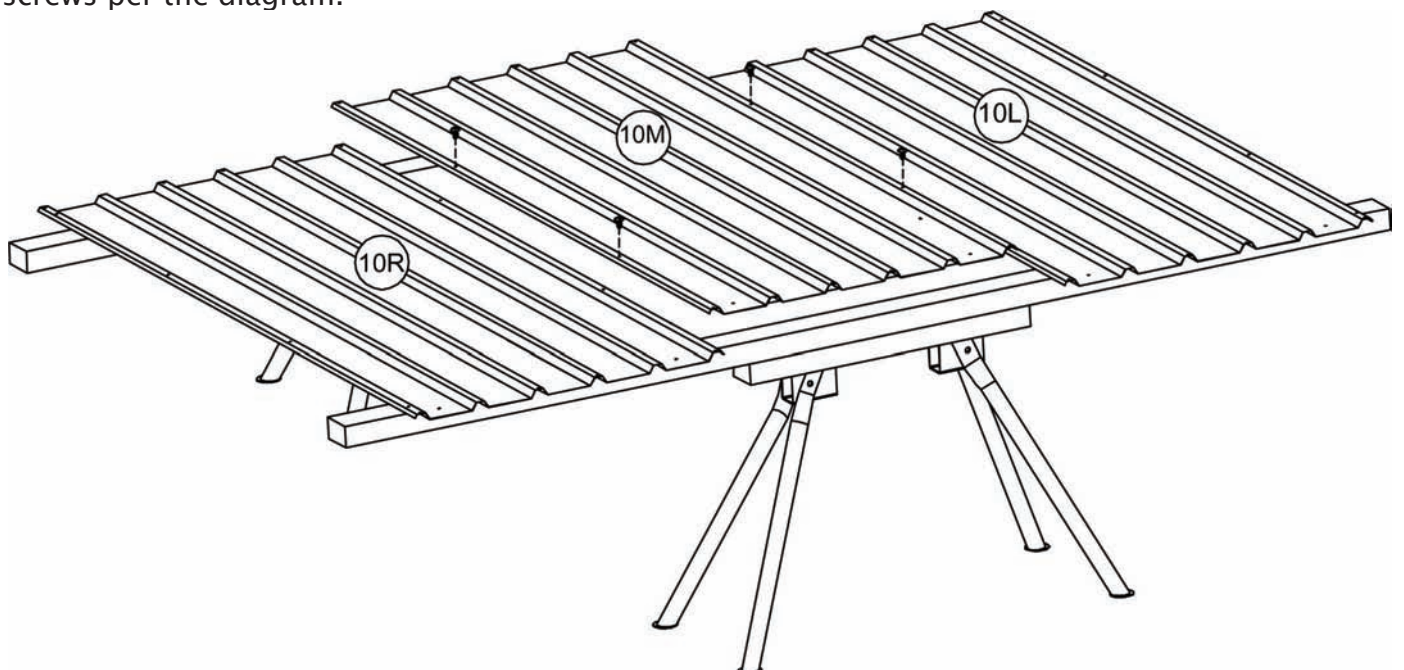

Fix 26F, 26E 26A and 26B the channel by self tapping screws per diagram. Please note that 26A and 26B are in the side with pre-punched holes on the sheeting.

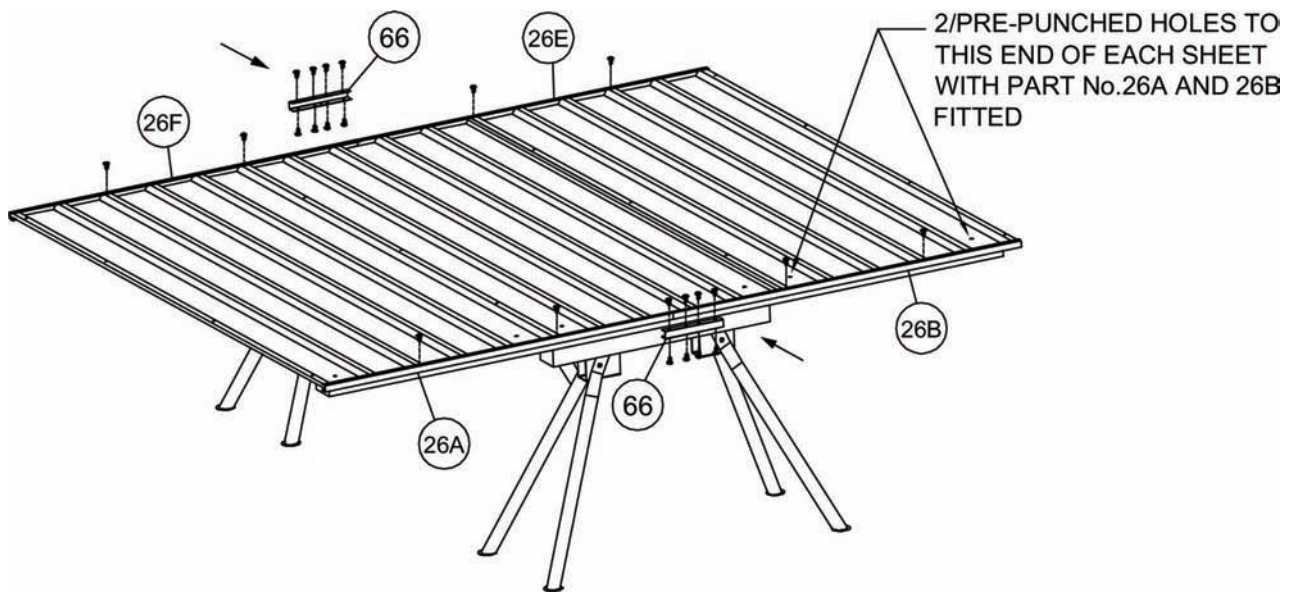

Enhance the strength by applying 66 the channel connectors. Note that screws are applied to both sides of the connectors.

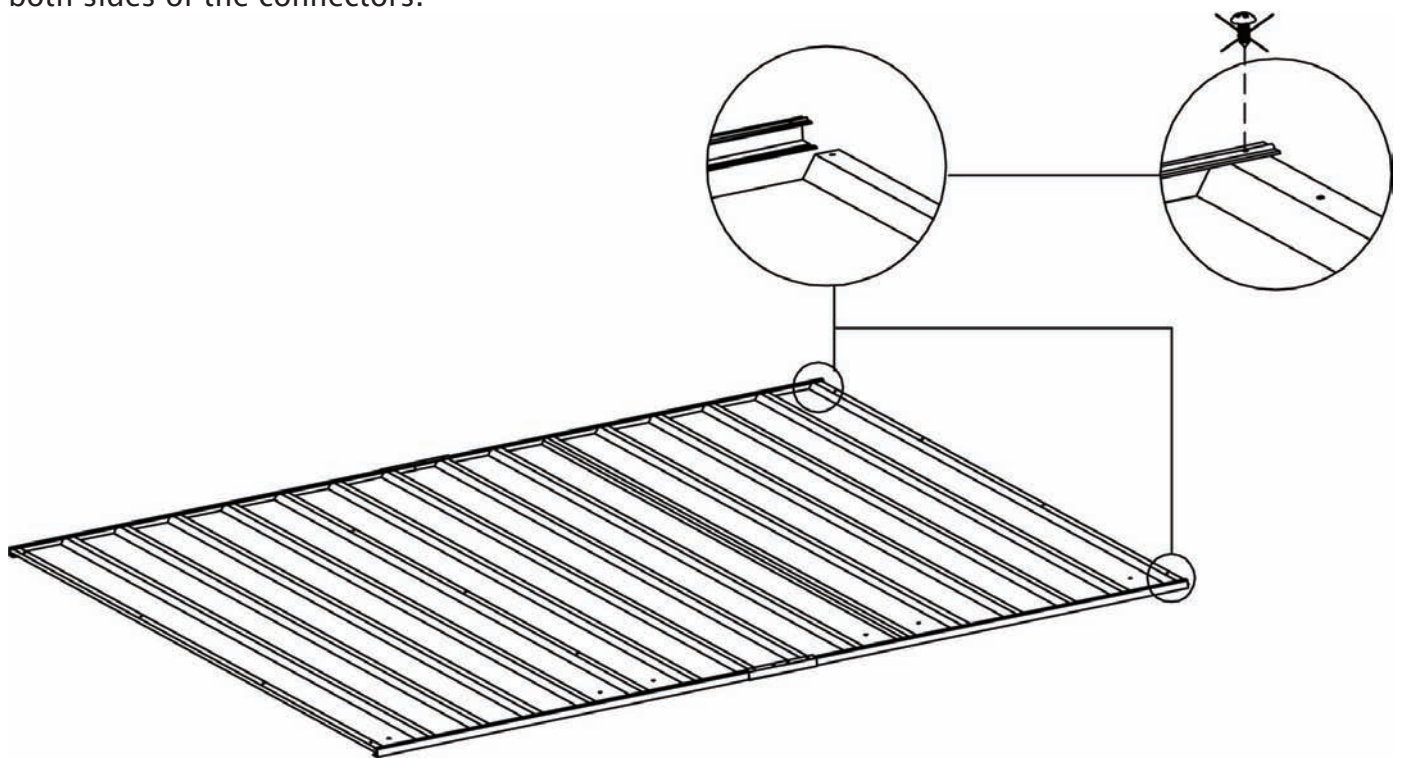

Leave 4 corners unfixed in this stage. Repeat the same steps for the other roof.

Now fix 33R and 33L the mid wall channels to the sheeting by the self tapping screws. Please note that the groove should face downwards.

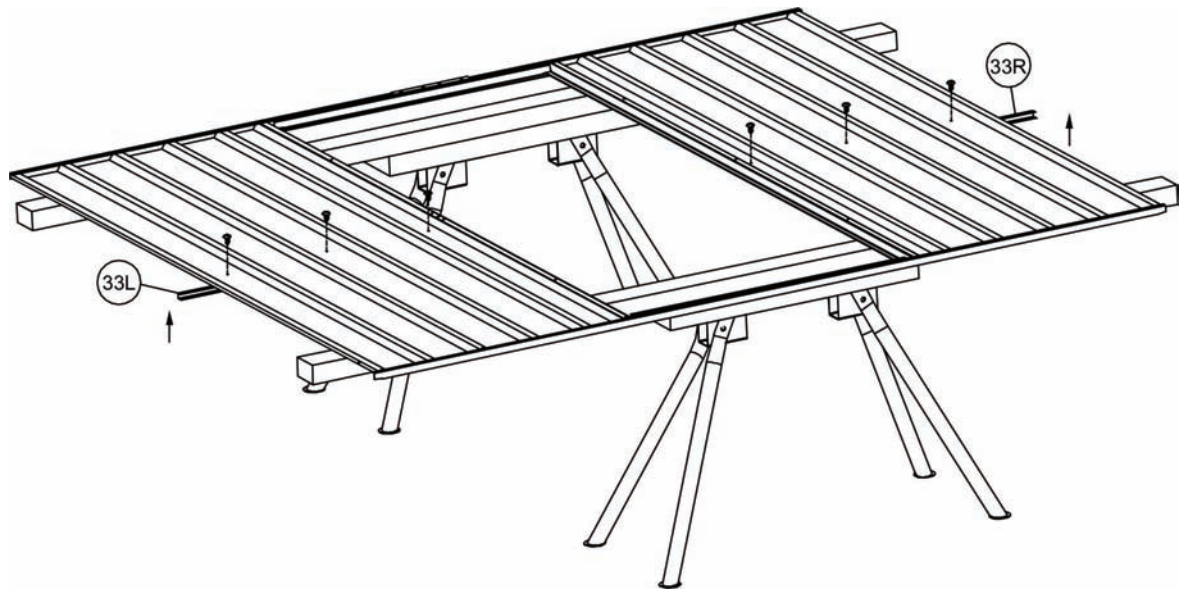

Step 6: Assemble the front door.

Fit 5R the pre-assembled door to the front wall panel per the diagram. Use riveter to fix the door to the pre-drilled holes.

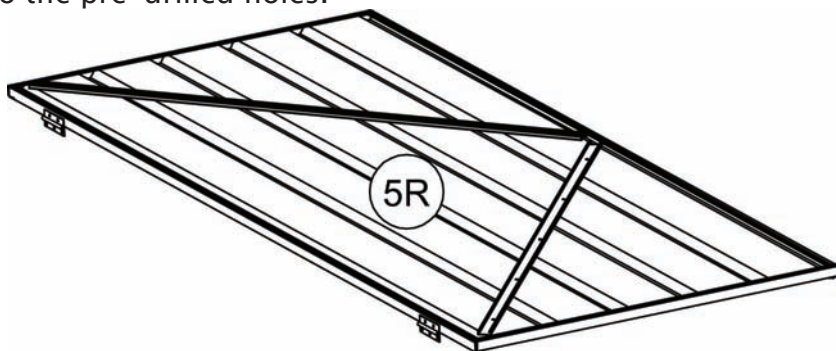

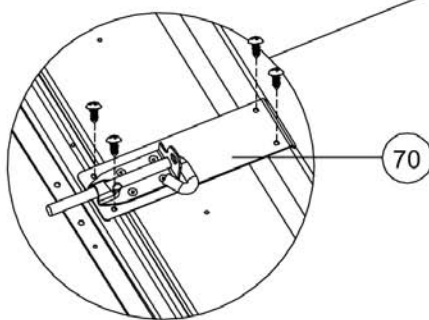
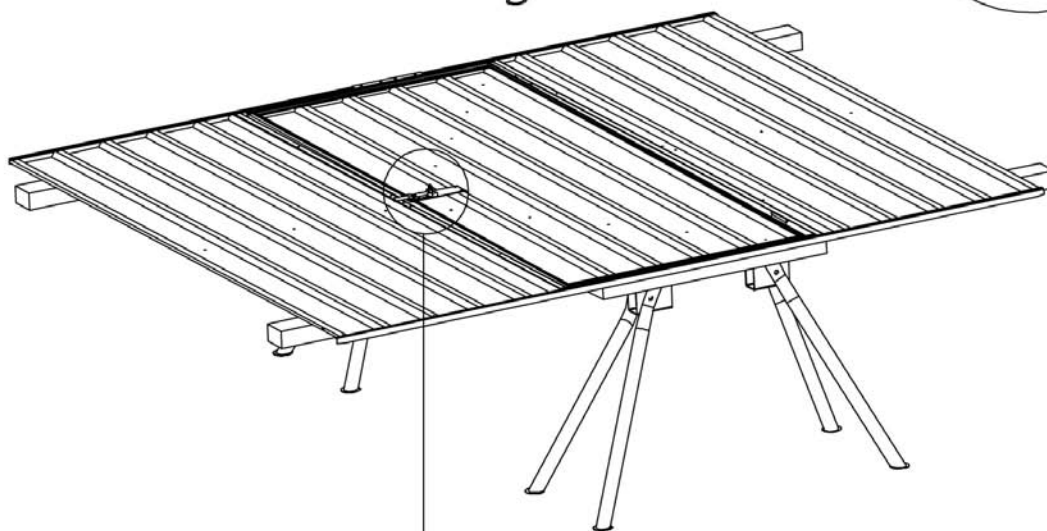
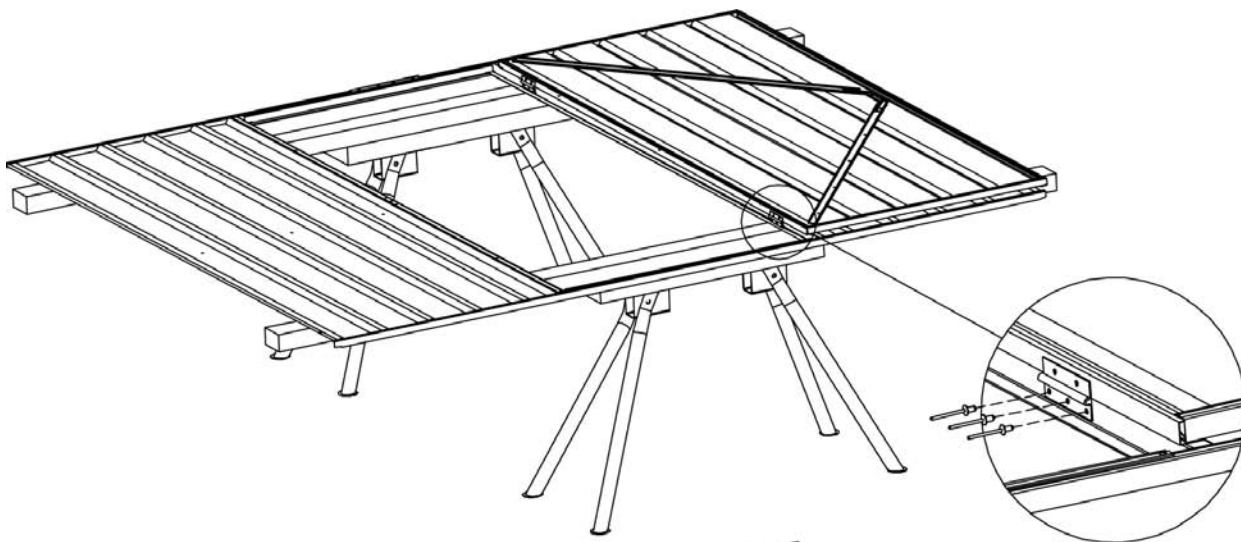

A

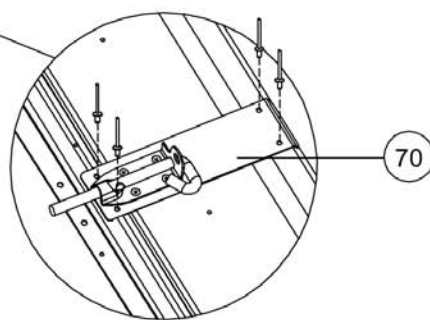

B

Use riveter to fix 70 the pad bolt to the pre-drill holes. Fix the pad bolt (but NOT the keeper at this stage) to the pre-drill holes using the self tapping screws (or the rivets provided.).

Step 7: Fit the panels together.

Now fix the front, side, rear panels and 2 x 63R, 2 x 63L the GABLE together using the holes provided and then fix the pad bolt using rivets.

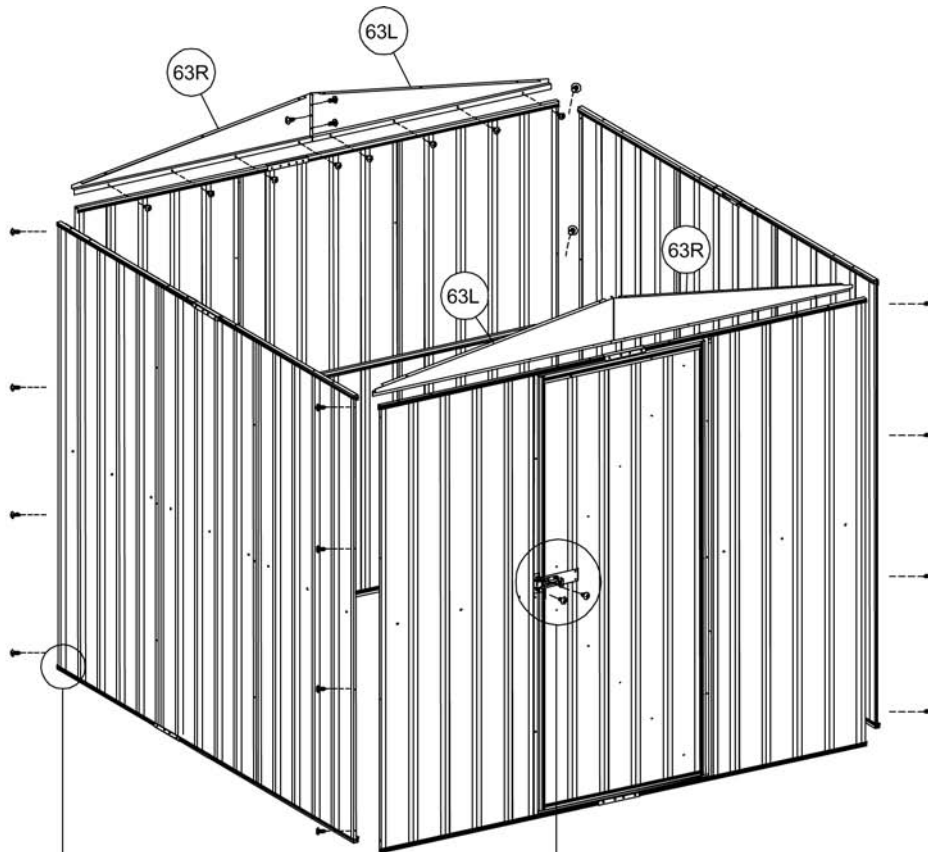

FIX PADBOLT KEEPER WITH 16mm SCREWS

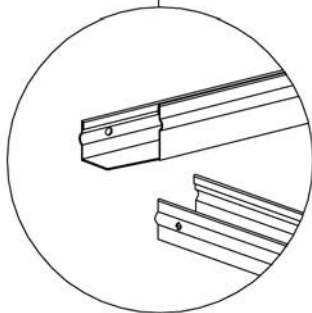

SIDE WALL PANEL CHANNELS FIT INTO THE NOTCHED FRONT AND REAR WALL PANEL CHANNELS

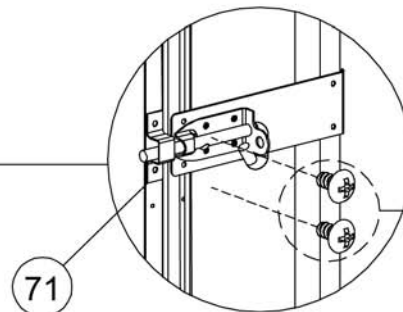
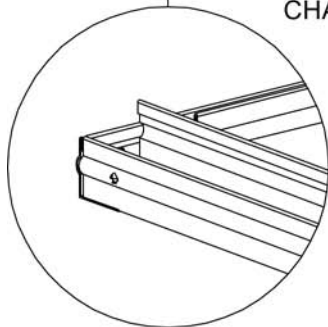

For extra security fit rivets as below

A

FIX PADBOLT KEEPER WITH 3.0*10MM RIVET

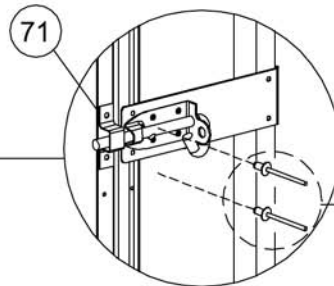

B

Join 62 the ridge beams with the end marked red arrow by 67 ridge beam connector. Put on 60 gable caps and join them by 61 gable cap connector. Fix this structure using 16mm self tapping screws.

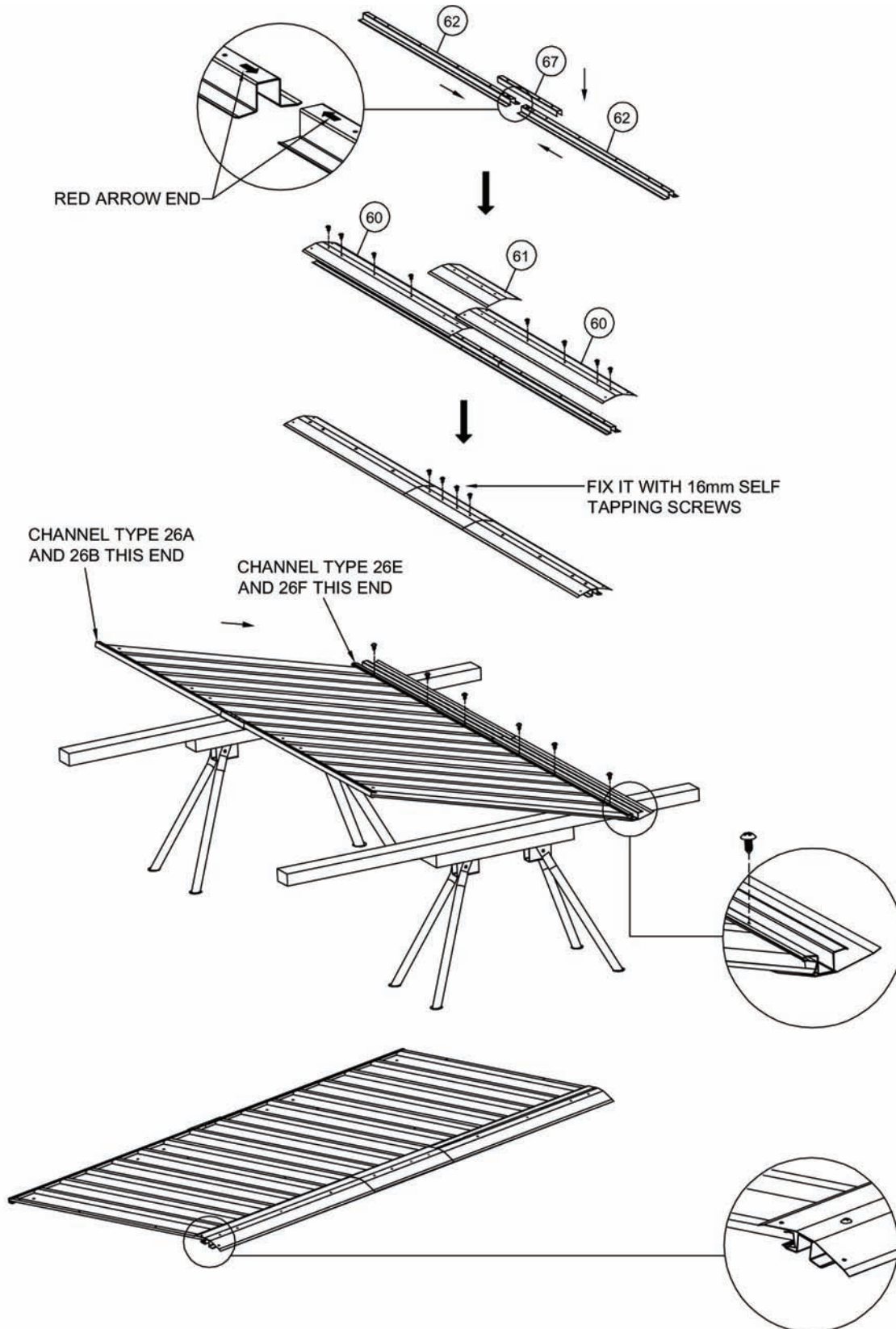

Slide in one side of the roof panel and note that the channel type 26E, 26F end is to the ridge beam.

Repeat the same step for the other assembled roof panel. Drill the holes through for roof brace by 3mm DRILL BIT. Then fix the roof brace per diagram. Join the sheeting and the gable by 52 the lip and then fix the 4 corners by 16mm self tapping screws. (central screws marked cross NOT fixed in this stage.)

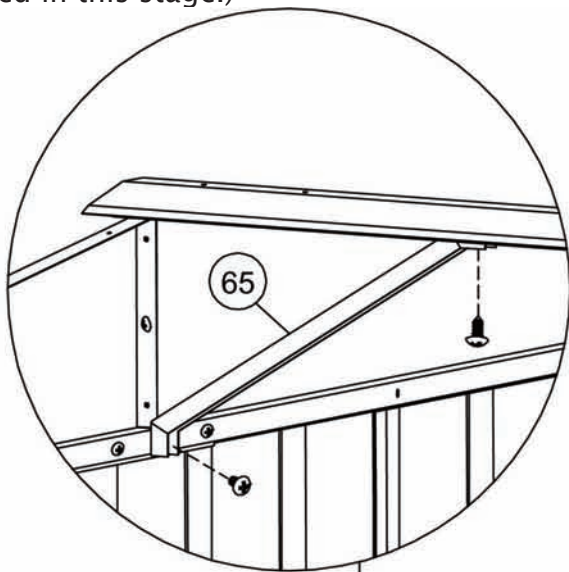

AFTER ATTACHING BOTH ROOF PANELS TO WALLS AS SHOWN ABOVE, DRILL THE HOLES THROUGH BY 3 MM DRILL BIT FOR THE ROOF BRACE AND FIX IT TO THE RIDGE BEAM AND FRONT WALL AS SHOWN. REPEAT THE SAME STEP FOR THE ROOF SIDE. THEN REPEAT THIS PROCEDURE FOR THE REAR WALL ROOF BRACE

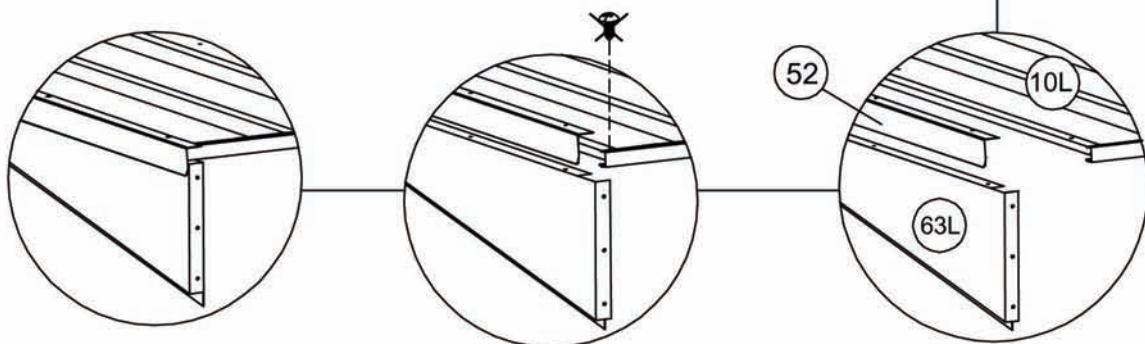
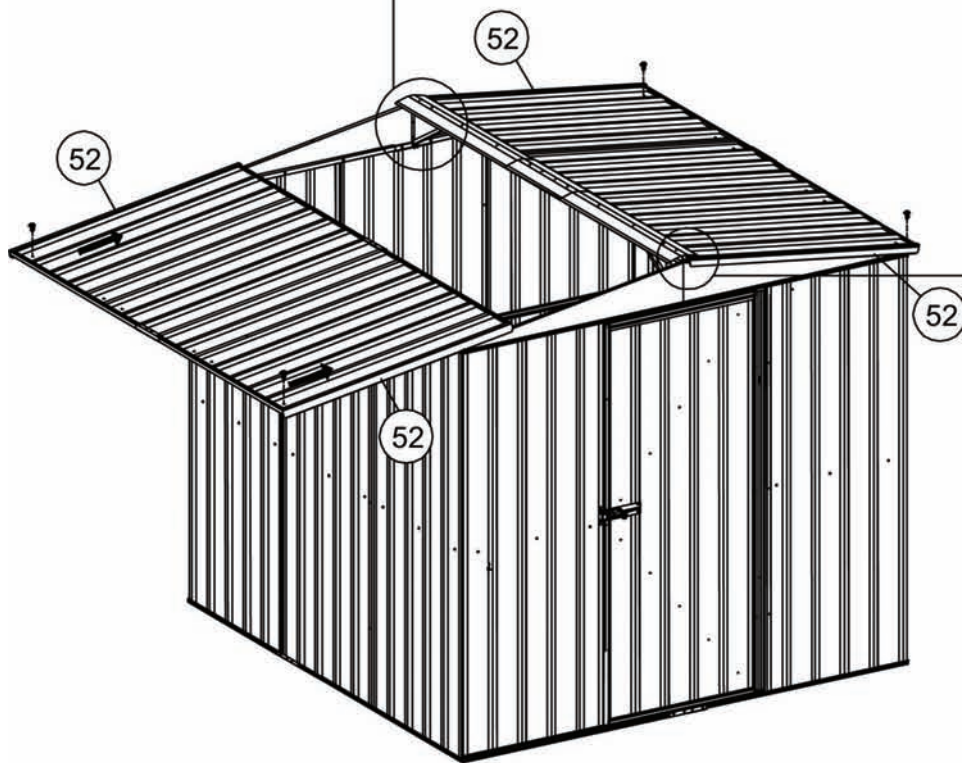

Put on the cap 64 and then fix the root panels by 16mm self tapping screws per diagram.

FIX IT WITH 16mm SELF TAPPING SCREWS

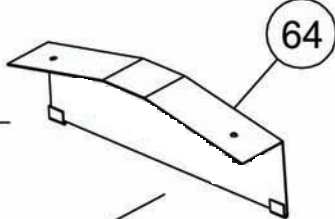
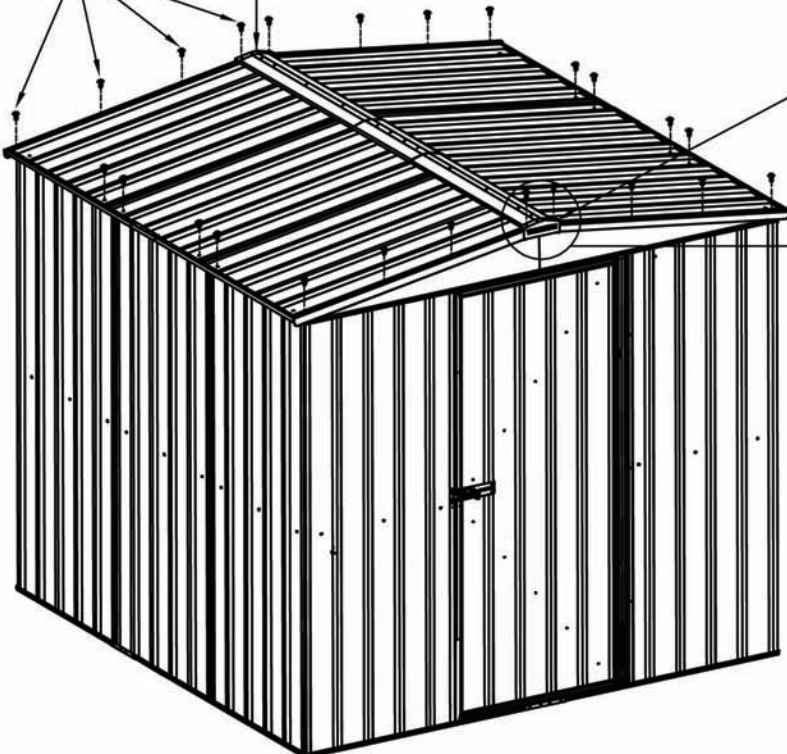

FIX IT WITH 16mm SELF TAPPING SCREWS

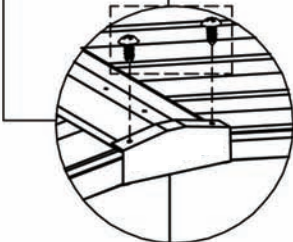

Now fit the bolt down kit as per the diagram. Please note that bolts are not supplied with this kit. Strengthen your mid wall brace by applying 72 the mid wall brace bracket on each corner if necessary.

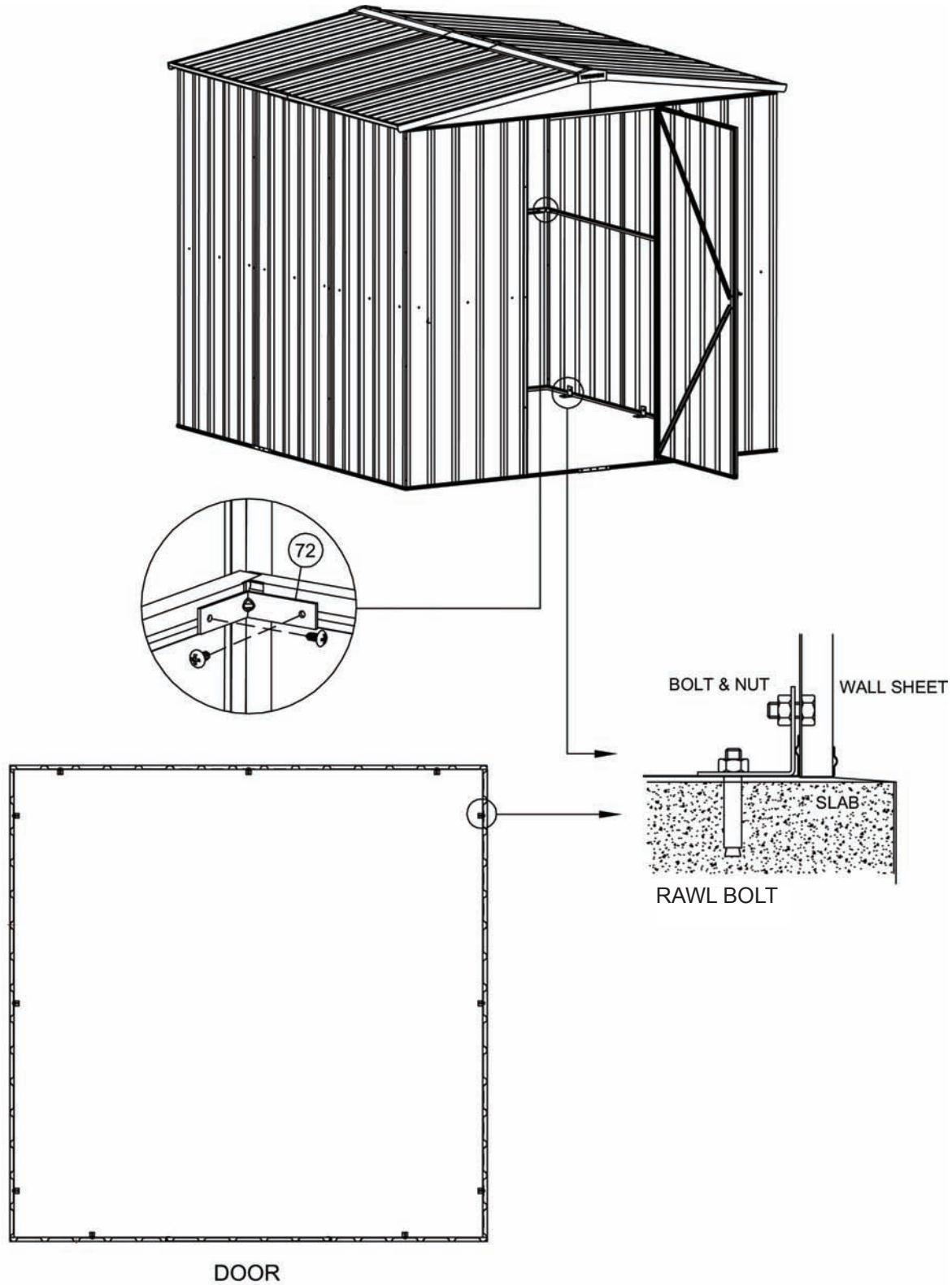

Apply channel safety cover **L** type on channel 33L and **R** type on channel 33R.
Also apply the self-tapper covers on the screws fixed on the wall.

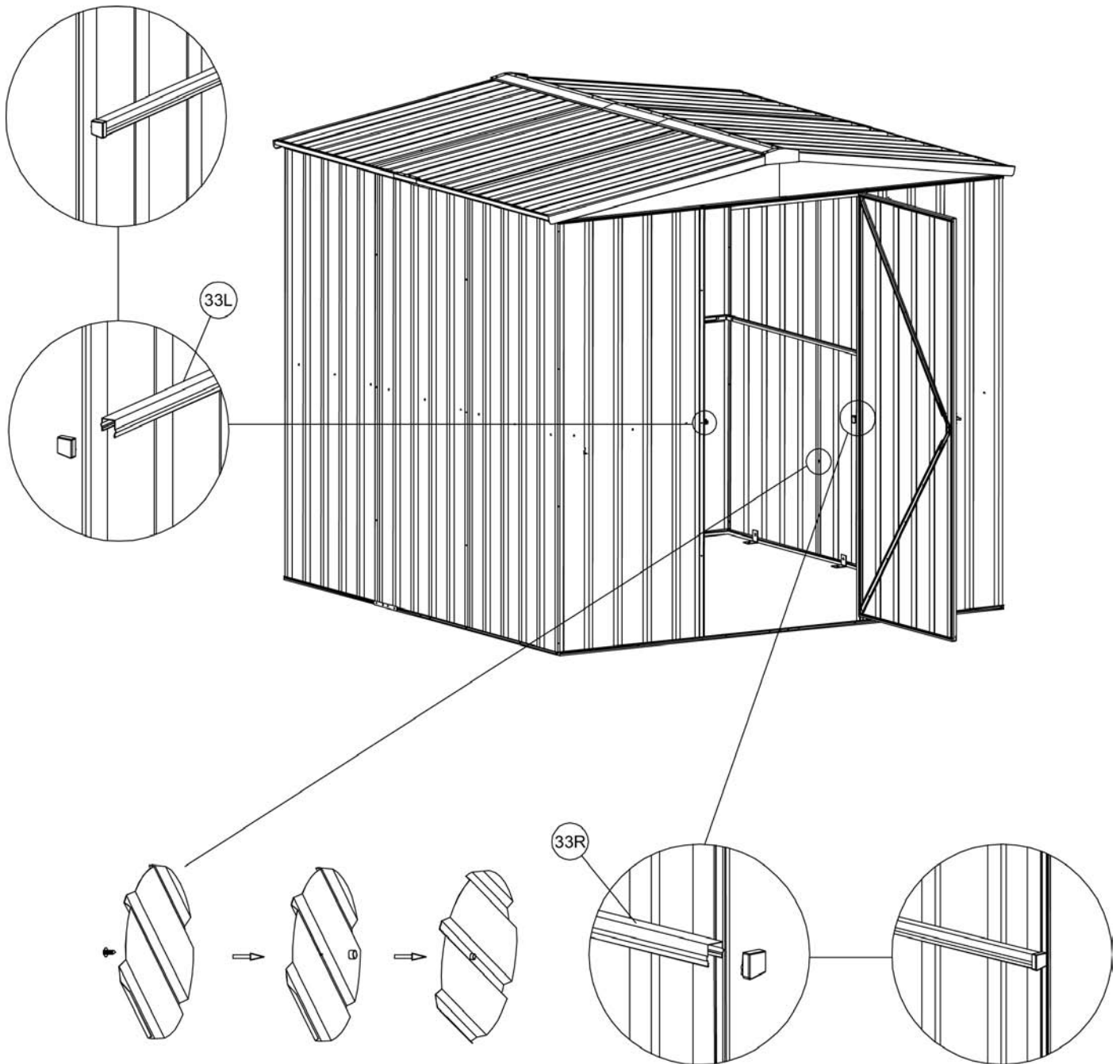

If required, the door can be assembled on the opposite side. Align the door with the edge and drill new holes. Remove the pin from the hinge and reverse it before assembling the door. Fill the old pre-drilled holes with rivets if required. Perform the same procedure for the pad lock.

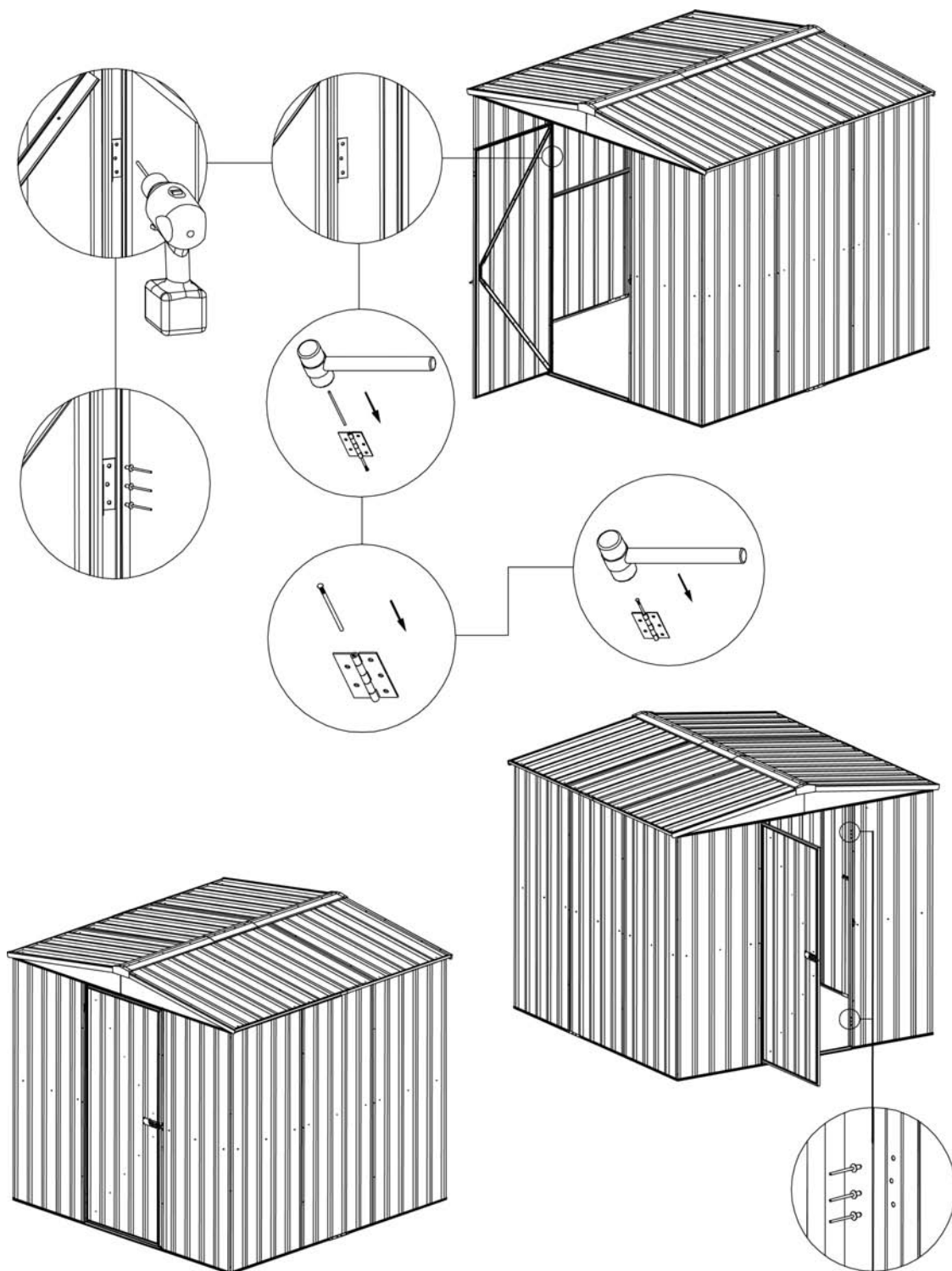

Sealey sheds are weatherproof, however, heavy winds with driving rain could cause your shed to leak. Condensation will also occur in some weather conditions such as extreme heat or cold. We would recommend the use of a waterproof sealant to help seal around all joins and wherever you feel that water may get in under these extreme conditions.

Shed is not to be used to store corrosive substances or as a chemical store.

NOTE: It is our policy to continually improve products and as such we reserve the right to alter data, specifications and component parts without prior notice.

IMPORTANT: No liability is accepted for incorrect use of this product.

WARRANTY: Guarantee is 12 months from purchase date, proof of which will be required for any claim.

INFORMATION: For a copy of our latest catalogue and promotions call us on 01284 757525 and leave your full name and address, including postcode.



Sole UK Distributor, Sealey Group,
Kempson Way, Suffolk Business Park,
Bury St. Edmunds, Suffolk,
IP32 7AR

01284 757500

www.sealey.co.uk

01284 703534

sales@sealey.co.uk