

Thank you for purchasing a Sealey product. Manufactured to a high standard this product will, if used according to these instructions and properly maintained, give you years of trouble free performance.

IMPORTANT: PLEASE READ THESE INSTRUCTIONS CAREFULLY. NOTE THE SAFE OPERATIONAL REQUIREMENTS, WARNINGS AND CAUTIONS. USE THIS PRODUCT CORRECTLY AND WITH CARE FOR THE PURPOSE FOR WHICH IT IS INTENDED. FAILURE TO DO SO MAY CAUSE DAMAGE AND/OR PERSONAL INJURY, AND WILL INVALIDATE THE WARRANTY. PLEASE KEEP INSTRUCTIONS SAFE FOR FUTURE USE.

1. SAFETY INSTRUCTIONS

1.1. ELECTRICAL SAFETY.

WARNING! It is the user's responsibility to read, understand and comply with the following:

You must check all electrical equipment and appliances to ensure they are safe before using. You must inspect power supply leads, plugs and all electrical connections for wear or damage. You must ensure the risk of electric shock is minimised by the installation of appropriate safety devices. An RCCB (Residual Current Circuit Breaker) should be incorporated in the main distribution board. We also recommend that an RCD (Residual Current Device) is used with all electrical products. It is particularly important to use an RCD with portable products that are plugged into an electrical supply not protected by an RCCB. If in doubt consult a qualified electrician. You may obtain a Residual Current Device by contacting your Sealey dealer. **You must** also read and understand the following instructions concerning electrical safety.

- 1.1.1. The **Electricity At Work Act 1989** requires all portable electrical appliances, if used on business premises, to be tested by a qualified electrician, using a Portable Appliance Tester (PAT), at least once a year.
- 1.1.2. The **Health & Safety at Work Act 1974** makes owners of electrical appliances responsible for the safe condition of those appliances and the safety of appliance operators. **If in any doubt about electrical safety, contact a qualified electrician.**
- 1.1.3. Ensure the insulation on all cables and the product itself is safe before connecting to the mains power supply. See 1.1.1. & 1.1.2. above and use a Portable Appliance Tester (PAT).
- 1.1.4. Ensure that cables are always protected against short circuit and overload.
- 1.1.5. Regularly inspect power supply leads and plugs for wear or damage and connections to ensure that none is loose.

1.1.6. **Important:** Ensure the voltage marked on the product is the same as the electrical power supply to be used, and check that plugs are fitted with the correct capacity fuse. A 13 amp plug may require a fuse smaller than 13 amps for certain products.

1.1.7. **DO NOT** pull power plugs from sockets by the power cable.

1.1.8. **DO NOT** use worn or damage leads, plugs or connections. Immediately replace or have repaired by a qualified electrician. Where a U.K. 3 pin plug with ASTA/BS approval is fitted, in case of damage, cut off and fit a new plug according to the following instructions (discard old plug safely).

(UK only - see diagram at right). **Ensure the unit is correctly earthed via a three-pin plug.**

- a) **Connect the GREEN/YELLOW earth wire to the earth terminal 'E'.**
- b) **Connect the BROWN live wire to the live terminal 'L'.**
- c) **Connect the BLUE neutral wire to the neutral terminal 'N'.**

After wiring, check there are no bare wires, that all wires have been correctly connected, that the cable outer insulation extends past the cable restraint and that the cable restraint is tight.

Double insulated products are often fitted with live (BROWN) and neutral (BLUE) wires only. Double insulated products are always marked with this symbol . **To re-wire, connect the brown & blue wires as indicated above. DO NOT connect the brown or blue wires to the earth terminal.**

1.1.9. **NOTE:** If this product requires more than a 13 amp electrical supply, then **NO** plug is fitted. **You must** therefore contact a qualified electrician to ensure a 30 amp fused supply is available. We recommend you discuss the installation of a industrial round pin plug and socket with your electrician.

1.1.10. **Cable extension reels.** When a cable extension reel is used it should be fully unwound before connection. A cable reel with an RCD fitted is recommended since any product which is plugged into the cable reel will be protected. The section of the cores in the cable is important and should be at least 1.5mm², but to be absolutely sure that the capacity of the cable reel is suitable for this product and for any that may be used in the other output sockets, the use of 2.5mm² section is recommended.

1.2. GENERAL SAFETY

WARNING! Disconnect drill from mains power before changing accessories, servicing or performing any maintenance.

✓ Maintain the drill in good condition (use an authorised service agent).

WARNING! Keep all guards and holding screws in place, tight and in good working order. Check regularly for damaged parts. A guard or any other part that is damaged must be repaired or replaced before the tool is next used, to ensure that it will operate properly and perform its intended function. The safety guard is a mandatory fitting where drill is used in premises covered by the Health & Safety at Work Act.

✓ Check alignment of moving parts and check for possible broken parts.

✓ Replace or repair damaged parts. *Use genuine Sealey parts only. Non-authorized parts may be dangerous and will invalidate the warranty.*

✓ Ensure the set screws of the head frame are screwed tight before using the drill.

✓ Secure the drill to the bench/floor to avoid the machine tipping, sliding or walking. Drill is designed for use with drill bits only. No other accessory may be used.

✓ Ensure the chuck is securely fastened to the spindle.

✓ Remove adjusting keys and wrenches from the machine and working area before switching on.

✓ Use clamps or a vice (not included) to secure the workpiece. Available from your Sealey dealer. **DO NOT** secure the workpiece by hand.

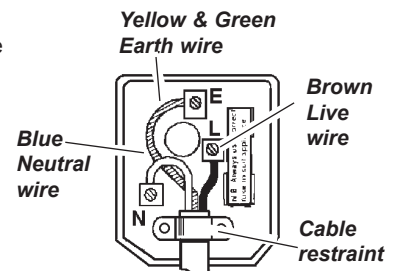

REPLACEMENT FUSES MUST BE OF THE SAME TYPE AND RATING AS THE ORIGINAL

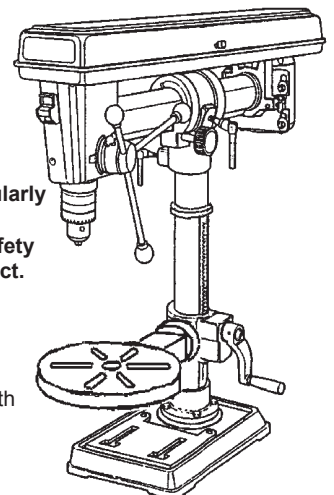

- ✓ Refer to speed chart for recommended drilling speeds.
- ☐ **WARNING! Always wear approved eye or face protection when operating this drill. Use a dust mask if dust is generated.**
- ☐ **WARNING! DO NOT wear gloves when drilling.**
- ✓ Others in the workplace should be kept at a safe distance from the drill, especially when it is in operation.
- ✓ Keep the work area as childproof as possible by using padlocks and master switches.
- ✓ Keep drill bits clean and sharp for best and safest performance.
- ✓ Remove ill fitting clothing. Remove ties, watches, rings and other loose jewellery and contain long hair.
- ✓ Locate the drill in a suitable work area, keep area clean and tidy and free from unrelated materials. Ensure there is adequate lighting.
- ✓ Maintain correct balance and footing. Ensure the floor is not slippery and wear non-slip shoes.
- ✓ Avoid unintentional starting.
- ✗ **DO NOT** use drill for a task it is not designed to perform.
- ✗ **DO NOT** allow untrained persons to operate the drill.
- ✗ **DO NOT** get the drill wet or use in damp or wet locations or areas where there is condensation.
- ✗ **DO NOT** operate the drill if damaged.
- ✗ **DO NOT** use drill in an area where paint fumes, solvents or flammable liquids pose a potential hazard. Keep flammable material away from the drill when operating. Flammable waste, such as wipes or cleaning rags, must be placed in a closed metal container and disposed of correctly.
- ✗ **DO NOT** exceed the rated capacity of the drill.
- ✗ **DO NOT** operate the drill if any parts are missing as this may cause failure and/or personal injury.
- ✗ **DO NOT** leave the drill operating unattended.
- ✗ **DO NOT** operate the drill when you are tired, under the influence of alcohol, drugs or intoxicating medication.
- ✓ When not in use switch off the drill, remove plug from the power supply and do not leave until the tool has come to a complete stop.

2. DESCRIPTION

The GDM790BR (bench) and GDM1630FR (floor) radial drills are suitable for light industrial, agricultural and woodworking applications. These 5 speed drills are fitted with flip-up safety guards and "No Volt Release" switches, which prevent accidental restart after a mains power interruption. The drill head is adjustable fore and aft to accommodate a large range of workpiece sizes and can be rotated to give angled drilling. A rack and pinion feed shaft with preset depth control for repetitive work is also included. Work clamps are available for these drills, contact your local Sealey dealer for information.

3. TECHNICAL SPECIFICATIONS

Model	GDM790BR	GDM1630FR
Chuck Size (mm)	16	16
Spindle Nose Taper	MT2	MT2
Head Rotation	45-0-90°	45-0-90°
Head Travel (mm)	320	320
Spindle Travel (mm)	80	80
Number of Speeds	5	5
Speed range (rpm)	500 - 2450	500 - 2450
Chuck to Table - max. (mm)	223	708
Chuck to Base - max. (mm)	390	1230
Chuck to Column - min. (mm)	120	115
Working Table (mm)	310	310
Working Base (mm)	165 x 155	200 x 185
Overall Base (mm)	340 x 210	420 x 250
Column Diameter (mm)	60	71
Overall Height (mm)	790	1630
Voltage (AC)	230	230
Motor Range - No Load (W)	370	370
- Under Load (W)	550	550
Weight (kg)	37	61

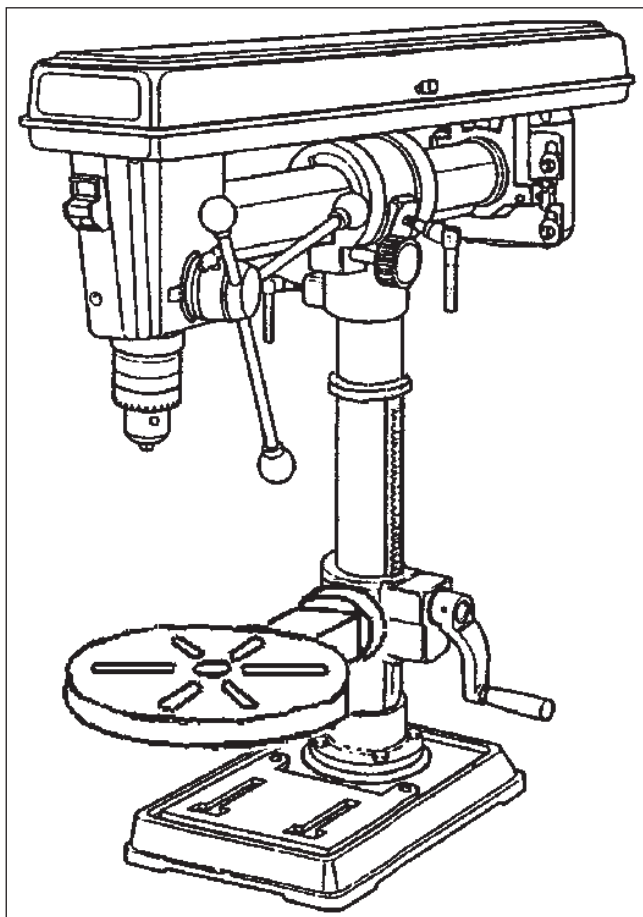

4. CONTENT

4.1. Content

Check parts against the list below. If any items are damaged or missing contact your supplier.

- ✓ Head Assembly
- ✓ Base
- ✓ Adjusting Handle (table)
- ✓ Chuck and Key
- ✓ Hex. Keys (2) & Wedge
- ✓ Coach Bolts & Wing Nuts
- ✓ Column with Flange
- ✓ Table
- ✓ Feed Handles and Knobs (3)
- ✓ Safety Guard
- ✓ Belt
- ✓ Rack & Rack Ring
- ✓ Table Arm, Bracket and Worm Gear
- ✓ Pivoted Clamp Bolts (4 - GDM790BR, 5 - GDM1630FR)
- ✓ Bolts (4)
- ✓ Locking Shoe

5. ASSEMBLY

Notes: 1) Diagrams are illustrative and may differ in detail from your drill.

2) Numbers in brackets refer to item numbers in the Parts List and Diagram

5.1. Assembly

- 5.1.1. Place the column (4) on the base (2), align holes and secure with the bolts (5) provided.
- 5.1.2. Insert worm gear (9) into table bracket, meshing it with the lift gear (7) (fig.1).
- 5.1.3. Fit table bracket (6) onto column (4) together with rack (15) (fig.2), engaging gear (7) in bracket with rack.
- 5.1.4. Install the rack collar (93) and tighten set screw (94) firmly (fig.3).
- 5.1.5. Fit the table adjusting handle (10) (fig.3.A) and lock handle (14) (fig.3.B).
- 5.1.6. Tighten the adjusting handle set screw (11) onto the flat on the worm gear shaft (9).
- 5.1.7. Install the table (16) and table lock handle (14) (fig.4).
- 5.1.8. Ensure that the column head assembly (83) is approximately midway between the motor (69) and the spindle housing (25) and then insert locking shoe (88) into column head (84) (fig.5).
- 5.1.9. Place the head assembly over the column (4) and slide column head (84) down onto column. Tighten lock handles (fig.6)

WARNING! If the column head assembly is not positioned midway there is a risk that the whole drill assembly may become unstable when the head assembly is fitted.

- 5.1.10. Screw the three feed handles and knobs (37/38) into the hub (35) of the pinion shaft.
- 5.1.11. To install chuck (46) open the chuck jaws completely by turning the chuck key (46A) counter-clockwise. Hold chuck on spindle and tap into place on taper with a hammer (fig.7).
- 5.1.12. Loosen clamp screw on safety guard mounting collar, pass guard up over chuck and fit collar round flange of quill (40). Ensure guard pivot is central and tighten clamp screw (see fig.8).
- 5.1.13. Open pulley cover (48), loosen butterfly set screw (36) on motor adjustment and fit belt (73) to pulleys (19/79). Pull motor (69) back to tension belt and retighten screw (36).

5.2. Drill mounting

WARNING! For stability and safety it is imperative that the drill base is securely bolted to the workbench (GDM790BR) or floor (GDM1630FR).

- 5.2.1. Ensure that the mounting surface is capable of supporting the drill together with the weight of the heaviest likely workpiece.

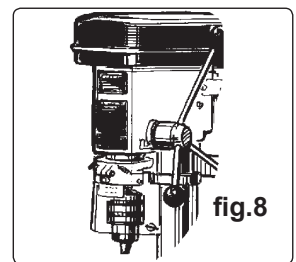
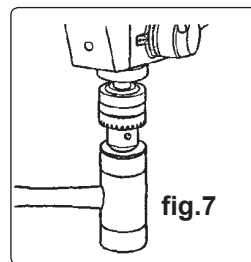
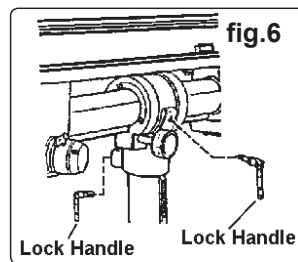
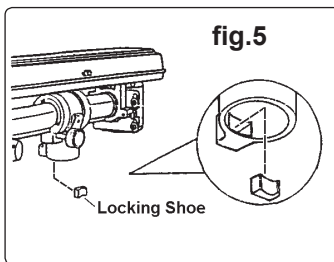
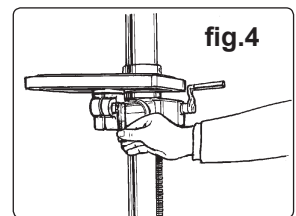
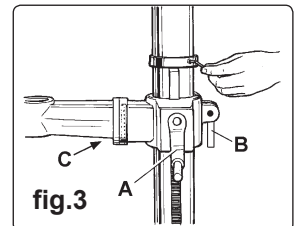
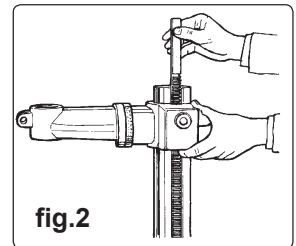
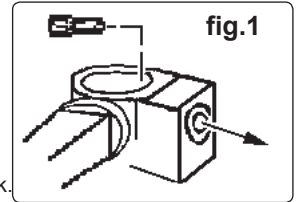

6. OPERATING INSTRUCTIONS

WARNING! Ensure the drill is unplugged from the mains power supply before commencing.

6.1. Installing drill bit

- 6.1.1. Insert drill bit into chuck jaws to 1" (25mm) deep (avoid inserting small bits too far) and centre bit in chuck before tightening.

6.2. Adjusting the table

- 6.2.1. To adjust table up or down, loosen lock handle (fig.3.B) then turn bracket handle (fig.3.A). Once at correct height tighten lock handle (fig.3.B).
- 6.2.2. To adjust table tilt, loosen the work table bolt (fig.3.C), adjust table to the desired angle, then retighten bolt.
- 6.2.3. To turn the table around the column, loosen the rack collar slightly, then loosen the lock handle (fig.3.B). Turn the table to the desired position then secure the lock handle and rack collar.

6.3. Adjusting the speed

- 6.3.1. Open the pulley cover (48) and loosen the motor adjustment screw (36).
- 6.3.2. Choose the speed for the drilling operation (see drill speed chart - Section 7) and move the belt to the correct pulley grooves for that speed, as shown on the pulley chart - Section 7.

6.4. Belt tension

- 6.4.1. With the motor adjustment clamp screw (36) loose and using hand pressure on the motor, set tension so that belt give is no more than 10mm each side, at centre span, under finger pressure. Tighten clamp screw (36).

6.5. Positioning the workpiece

- 6.5.1. Rest the workpiece on a piece of wood to prevent the drill bit damaging the table when it breaks through the workpiece. The wood should rest on the table so that one end of it is against the left side of the column. This will prevent the wood spinning when the drill bit breaks through into it.
- 6.5.2. For small workpieces that cannot be clamped to the table, use a drill vice (not included). Vice must be bolted to table.

6.6. Setting the drill depth

- 6.6.1. Use the scale on the side of the drill head near the drill handle.
- 6.6.2. Loosen locking screw (36) and set the scale to the depth required. Tighten locking screw.
- 6.6.3. When ready to drill, simply pull the feed handle. The drill will stop at the set depth.

6.7. Setting the drill head

6.7.1. Fore and aft movement

- 6.7.1.1. Loosen clamping lever (fig.9.A) and turn feed knob (fig.9.B) to move head to the required position. Retighten clamping lever.

6.7.2. Horizontal rotation

- 6.7.2.1. Loosen clamping lever (fig.10.A) and rotate head on column to required position (360° rotation is available). Retighten clamping lever.

6.7.3. Tilting

- 6.7.3.1. Loosen clamping lever (fig.9.A), Pull out and turn - to hold out - vertical lock (fig.10.B). Head may now be tilted up to 45° clockwise and 90° anticlockwise. Angular position is shown by line (fig.9.C) against scale (fig.9.D). When set, retighten clamping lever. After returning head to the vertical position always re-engage the vertical lock.

6.7.4. Head square to table

- 6.7.4.1. Confirm that head is in the 'vertical' position, that the vertical lock (fig.10.B) is engaged and that the clamping lever (fig.9.A) is tight.
- 6.7.4.2. Using a spirit level check that table is horizontal and, if necessary, adjust as in para.6.2.2.
- 6.7.4.3. Clamp a straight rod, or a drill bit, in the chuck and use a machinist's square to check that the rod is perpendicular to the table. Adjust drill head as necessary by loosening the two set screws (fig.11.A) either side of the spindle housing and rotating the housing on the horizontal tube (81). When correctly positioned retighten set screws.

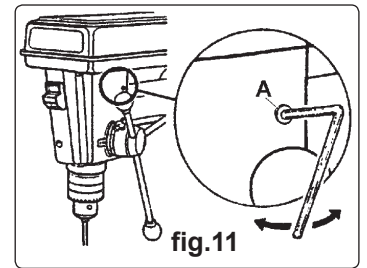
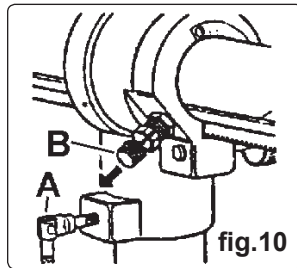
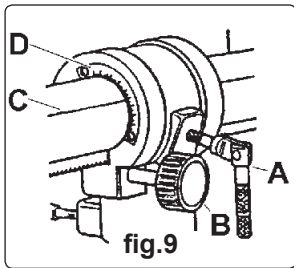

7. DRILL SPEEDS

The chart below shows recommended drill speeds for various bit diameters and materials. Select the available drill speed that is the same as, or nearest to, the one recommended for the task in hand.

Drill Diameter (mm)	Drill Speed (rpm)			
	Steel	Cast Iron	Iron	Alum' & Copper
3	1820	2580	2580	2580
4	1350	1820	1820	2580
5	1290	1350	1350	2580
6	970	1290	1290	2580
7	830	970	970	2580
8	830	970	970	2580
9	500	970	830	1820
10	500	830	830	1820
11	500	830	830	1820
12	420	830	500	1820
13	420	500	500	1350
14	420	500	500	1350
16	320	500	500	1290
18	320	420	420	1290
20	280	320	320	970
22	210	320	280	970
25	120	280	210	830

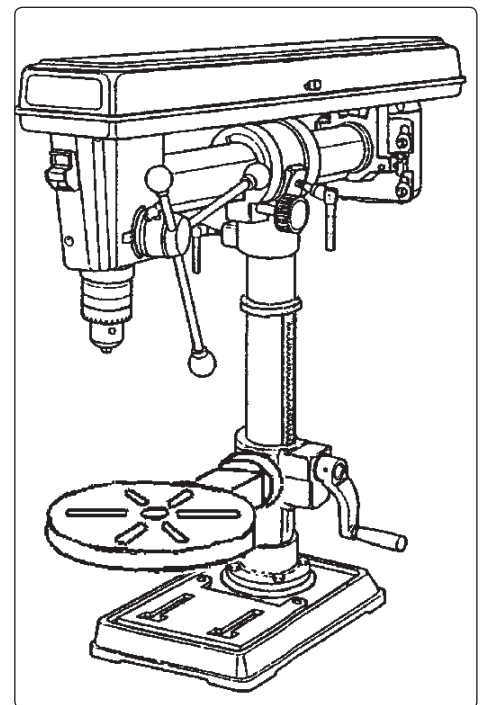

Drill Speed (rpm)

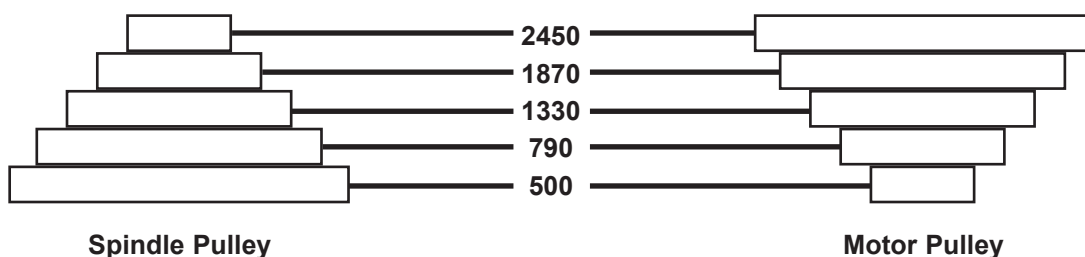

8. MAINTENANCE

- 8.1. Clean the drill after each use. A coat of automobile-type wax applied to the table and column will help to keep the surfaces clean.
- 8.2. Blow out any dust that may have accumulated in the motor.
- 8.3. Periodically lubricate the table elevation rack/gear/worm mechanism.

9. TROUBLESHOOTING

PROBLEM	POSSIBLE CAUSE	SOLUTION
Excessive noise	<ol style="list-style-type: none"> 1. Incorrect belt tension 2. Spindle is dry 3. Pulley is loose 4. Bearing damaged 	<ol style="list-style-type: none"> 1. Adjust tension 2. Disassemble spindle/quill and lubricate 3. Tighten pulley 4. Replace the bearing
Excessive drill wobble	<ol style="list-style-type: none"> 1. Chuck is loose 2. Bearing or spindle shaft is worn 3. Chuck is worn 	<ol style="list-style-type: none"> 1. Refit the chuck (see 5.1.11) 2. Replace worn part 3. Replace the chuck
Drill binds in the workpiece	<ol style="list-style-type: none"> 1. Feed pressure is wrong 2. Belt is loose 3. Drill bit is loose 4. Speed is too fast 	<ol style="list-style-type: none"> 1. Apply less pressure 2. Adjust tension 3. Tighten the chuck jaws with the key 4. Change the speed
Drill burns or smokes	<ol style="list-style-type: none"> 1. Speed is too fast 2. Chips are not discharging 3. Drill bit is dull 4. Lubrication needed 5. Feed pressure is wrong 	<ol style="list-style-type: none"> 1. Change the speed 2. Clean the drill bit 3. Use a new bit 4. Lubricate while drilling 5. Apply less pressure
Table is difficult to raise	<ol style="list-style-type: none"> 1. Lubrication is needed 2. Rack is bent 	<ol style="list-style-type: none"> 1. Lubricate with light oil 2. Straighten the rack

NOTE: It is our policy to continually improve products and as such we reserve the right to alter data, specifications and component parts without prior notice.

IMPORTANT: No liability is accepted for incorrect use of this product.

WARRANTY: Guarantee is 12 months from purchase date, proof of which will be required for any claim.

INFORMATION: For a copy of our latest catalogue and promotions call us on 01284 757525 and leave your full name and address, including postcode.



Sole UK Distributor, Sealey Group,
Kempson Way, Suffolk Business Park,
Bury St. Edmunds, Suffolk,
IP32 7AR



01284 757500



www.sealey.co.uk



01284 703534



sales@sealey.co.uk