

Thank you for purchasing a Sealey product. Manufactured to a high standard this product will, if used according to these instructions and properly maintained, give you years of trouble free performance.



IMPORTANT: PLEASE READ THESE INSTRUCTIONS CAREFULLY. NOTE THE SAFE OPERATIONAL REQUIREMENTS, WARNINGS, AND CAUTIONS. USE THIS PRODUCT CORRECTLY, AND WITH CARE FOR THE PURPOSE FOR WHICH IT IS INTENDED. FAILURE TO DO SO MAY CAUSE DAMAGE AND/OR PERSONAL INJURY AND WILL INVALIDATE THE WARRANTY.

1. SAFETY INSTRUCTIONS

1.1. ELECTRICAL SAFETY

WARNING! It is the responsibility of the owner and the operator to read, understand and comply with the following:

You must check all electrical products, before use, to ensure that they are safe. You must inspect power cables, plugs, sockets and any other connectors for wear or damage. You must ensure that the risk of electric shock is minimised by the installation of appropriate safety devices. A Residual Current Circuit Breaker (RCCB) should be incorporated in the main distribution board. We also recommend that a Residual Current Device (RCD) is used. It is particularly important to use an RCD with portable products that are plugged into a supply which is not protected by an RCCB. If in any doubt consult a qualified electrician. You may obtain a Residual Current Device by contacting your Sealey dealer. You must also read and understand the following instructions concerning electrical safety.

- 1.1.1. The **Electricity at Work Act 1989** requires that all portable electrical appliances, if used on business premises, are tested by a qualified electrician, using a Portable Appliance Tester (PAT), at least once a year.
- 1.1.2. The **Health & Safety at Work Act 1974** makes owners of electrical appliances responsible for the safe condition of those appliances and the safety of the appliance operators. If in any doubt about electrical safety, contact a qualified electrician.
- 1.1.3. Ensure that the insulation on all cables and on the appliance is safe before connecting it to the power supply. See 1.1.1. and 1.1.2. and use a Portable Appliance Tester.
- 1.1.4. Ensure that cables are always protected against short circuit and overload.
- 1.1.5. Regularly inspect power supply cables and plugs for wear or damage and check all connections to ensure that none is loose.
- 1.1.6. **Important:** Ensure that the voltage marked on the appliance matches the power supply to be used and that the plug is fitted with the correct fuse - see fuse rating above/right.
- 1.1.7. **DO NOT** pull or carry the appliance by the power cable.
- 1.1.8. **DO NOT** pull the plug from the socket by the cable.
- 1.1.9. **DO NOT** use worn or damaged cables, plugs or connectors. Immediately have any faulty item repaired or replaced by a qualified electrician. When a BS 1363/A UK 3 pin plug is damaged, cut the cable just above the plug and **dispose of the plug safely**. Fit a new plug according to the following instructions (UK only). See above/right.

- a) **Connect the GREEN/YELLOW earth wire to the earth terminal 'E'.**
- b) **Connect the BROWN live wire to the live terminal 'L'.**
- c) **Connect the BLUE neutral wire to the neutral terminal 'N'.**
- d) **After wiring, check that there are no bare wires, that all wires have been correctly connected, that the cable outer insulation extends beyond the cable restraint and that the restraint is tight.**

Double insulated products, which are always marked with this symbol , are fitted with live (brown) and neutral (blue) wires only. To rewire, connect the wires as indicated above/right. **DO NOT** connect either wire to the earth terminal.

- 1.1.10. Products which require more than 13 amps are supplied without a plug. In this case you must contact a qualified electrician to ensure that a suitably rated supply is available. We recommend that you discuss the installation of an industrial round pin plug and socket with your electrician.
- 1.1.11. If an extension reel is used it should be fully unwound before connection. A reel with an RCD fitted is preferred since any appliance plugged into it will be protected.

The cable core section is important and should be at least 1.5mm², but to be absolutely sure that the capacity of the reel is suitable for this product and for others which may be used in the other output sockets, we recommend the use of 2.5mm² section cable.

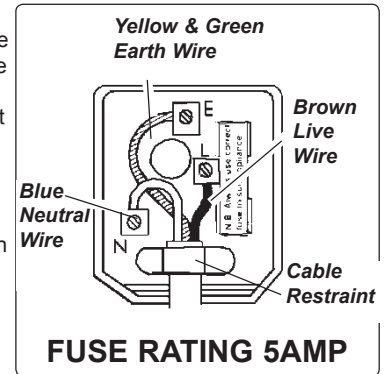

1.2. GENERAL SAFETY

WARNING!

- Disengage the grease gun from the battery before changing accessories, servicing or performing and maintenance.
- ✓ Maintain gun in good condition (use an authorised service agent).
- ✓ Replace or repair damaged parts. *Use recommended parts only. Unauthorised parts may be dangerous and will invalidate the warranty.*
- ✓ Wear appropriate protective clothing. When handling lubricants refer to manufacturer's instructions and conform to local regulations.
- ✓ Use the gun in a suitable working area. Keep area clean and tidy and free from unrelated materials and ensure there is adequate lighting.
- ✓ Maintain correct balance and footing whilst performing the task. Ensure floor is not slippery and wear non-slip shoes.
- ✓ Keep children and unauthorised persons away from the work area.
- ✓ Dispose of waste grease in accordance with local authority regulations.
- ✓ When not in use ensure the battery is removed.
- ✗ **DO NOT** allow unauthorised persons to operate the gun.
- ✗ **WARNING! DO NOT tamper with or open pump unit.** *Doing so will invalidate your warranty.*
- ✗ **DO NOT** point grease gun at yourself or other persons or animals.
- ✗ **DO NOT** pull the grease gun unit by the hose.
- ✗ **DO NOT** use the gun for a task it is not designed to perform.
- ✗ **DO NOT** operate the gun when you are tired or under the influence of alcohol, drugs or intoxicating medication.
- ✓ When not in use, clean the unit and store in a dry, safe, childproof area.

2. INTRODUCTION & SPECIFICATION

High power, professional, cordless grease gun, developing 7000psi. Ideal for in-field lubrication where power and speed are required. Suitable for 400g cartridges, manual or bulk filling. Features LCD battery condition indicator, air bleed and heavy-duty aluminium pressure head. Supplied with 18V 1.7Ah battery and mains charger. Supplied in carry-case.

Model No. **CPG18V**
Voltage:..... 18V
Pressure: 8000psi
Flow Rate 100g/min
Hose Length: 700mm
Replacement Battery:..... CPG18VBP

3. OPERATION

- ❑ **IMPORTANT WARRANTY INFORMATION:**
the battery pack fitted to this cordless tool are considered to be a consumable item and its ability to accept charge will reduce over time. We will warranty it against mechanical and electrical defect for a period of one year - this does not cover fair wear and tear. If the battery is not properly charged before 1st use, or regularly conditioned, its capacity will diminish. Under these circumstances we will not replace the battery pack even if it is less than one year old.

3.1 CHARGING THE BATTERY

Important: Before using the grease gun for the first time the battery must be charged for a minimum of 1.5 hours.

- 3.1.1 To charge the battery, slot the ridges on the battery into the keyways on the charger and push on until the battery stops. Press the red release catches inwards and push the battery fully home until the body of the battery makes contact with the body of the charger as shown in Fig.1. To release the battery, simply push it off in the direction shown.
- ❑ **WARNING!** Do not obstruct the vents situated on the top and bottom of the charger as this will cause the charger to overheat.
- 3.1.2 Plug the charger into the mains power supply. A red LED will light on the charger indicating that charging has commenced. When the battery is fully charged the red LED will go out and the green LED will illuminate. See Fig.1.
- 3.2 **ATTACHING THE BATTERY PACK TO GREASE GUN**
- 3.2.1 To attach the battery, line up the ridges on the battery moulding with the keyways at the base of the handle and slide the battery towards the grease canister until it clicks into place.
- 3.2.2 To remove the battery from the unit press the two red release catches located each side of the battery simultaneously and slide the battery off the base of the handle.



3.3 PRIMING THE GUN

- 3.3.1 Before loading the gun with a cartridge or filling via a grease bucket, the gun must be primed.
- 3.3.2 To prime the gun, pack grease into the cavity located at the entrance of the gun assembly (where the grease tube screws into the gun). When the filled grease canister is attached, operate the trigger to induce the intake of grease into the gun assembly.

3.4 REMOVING EMPTY GREASE CARTRIDGE

- 3.4.1 Fully draw back the plunger handle. When released it will automatically be locked by the catch plate. See Fig.4J.
- 3.4.2 Unscrew the grease canister from the grease gun.
- 3.4.3 To eject the cartridge, hold the plunger handle, press the catch plate and hold it down whilst slowly releasing the plunger.

3.3 PRIMING THE GUN

- 3.3.1 Before loading the gun with a cartridge or filling via a grease bucket, the gun must be primed.
- 3.3.2 To prime the gun, pack grease into the cavity located at the entrance of the gun assembly (where the grease tube screws into the gun). When the filled grease canister is attached, operate the trigger to induce the intake of grease into the gun assembly.

3.4 REMOVING EMPTY GREASE CARTRIDGE

- 3.4.1 Fully draw back the plunger handle. When released it will automatically be locked by the catch plate. See Fig.4J.
- 3.4.2 Unscrew the grease canister from the grease gun.
- 3.4.3 To eject the cartridge, hold the plunger handle, press the catch plate and hold it down whilst slowly releasing the plunger.

3.5 LOADING A NEW GREASE CARTRIDGE

- 3.5.1 Unscrew the grease canister from the grease gun. Eject the old cartridge as described in section 3.4.
- 3.5.2 Fully draw back the plunger handle again. When released it will automatically be locked by the catch plate. See Fig.4J.
- 3.5.3 Remove the base cap from the grease cartridge.
- 3.5.4 Insert the open end of the cartridge into the grease canister and push it all the way in (Fig.2A). Remove the seal or pull tab from the other end of the cartridge.
- 3.5.5 Pack grease into the cavity in the pump head where the grease canister attaches.
- 3.5.6 Screw the grease canister into the grease gun. Press and hold down the catch plate to release the plunger rod.
- 3.5.7 Purge air from the system. See Section 3.9.

3.6 SUCTION FILLING

- 3.6.1 Unscrew the grease tube from the grease gun and eject the cartridge, if fitted.
- 3.6.2 Ensure the plunger rod has been released by pressing the catch plate. See Fig.4J.
- 3.6.3 Pack grease into the cavity in the pump head where the grease canister attaches.
- 3.6.4 Submerge the open end of the grease canister into a grease bucket by approximately 50mm (2"). Slowly pull out the plunger rod whilst pushing the canister deeper into the grease to prevent air pockets from being pulled into the canister (Fig.2B). Continue until the rod is fully extended and locked by the catch plate (Fig.4J).
- 3.6.5 Screw the grease canister back into the grease gun. Press the catch plate and release the plunger rod.
- 3.6.6 Press and hold the catch plate and push the plunger rod down until some resistance is felt. Release the catch plate.

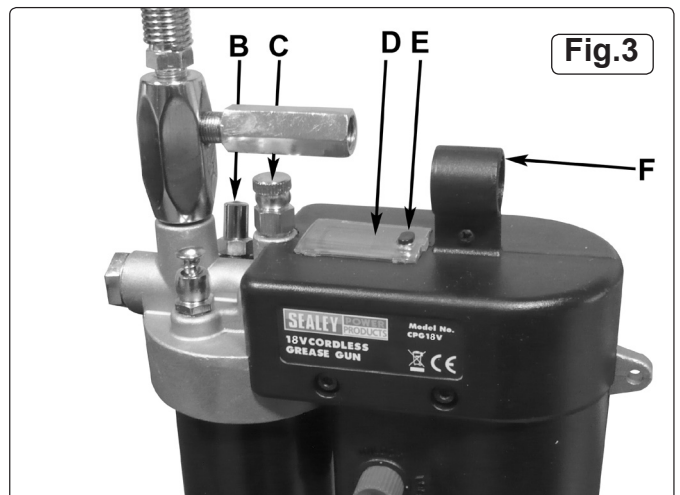
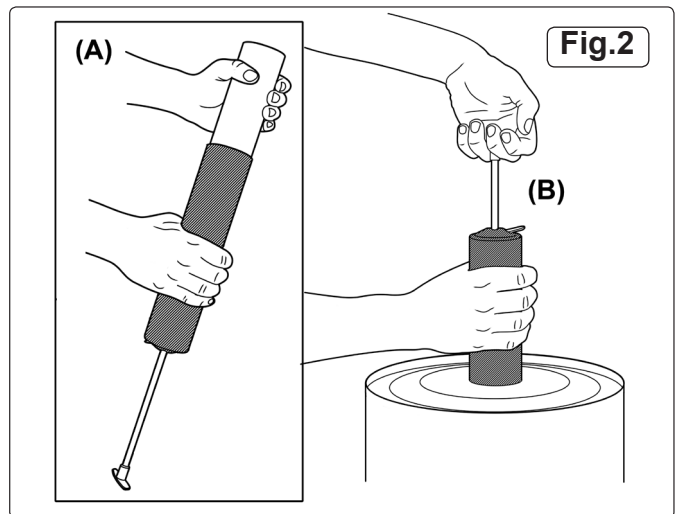

3.7 BULK FILLING

- 3.7.1 Press the catch plate to release the plunger rod.
- 3.7.2 Connect a low pressure bulk greasing unit to the bulk filler nipple (Fig.3B) at the top of the gun and fill until plunger rod is fully extended.
- 3.7.3 Press and hold the catch plate and push the plunger rod down until some resistance is felt. Release catch plate.

3.8 OPERATION

- 3.8.1 Turn the trigger locking knob to the upper "unlock" position.
- 3.8.2 Slide the grease tube connector out of the stowage point on the top of the unit (Fig.3F) and push the connector onto the chosen grease nipple and operate the trigger until the desired amount of grease has been dispensed.
- 3.8.3 When the grease gun is not in use turn the trigger locking button (Fig 4.4) to the lower "lock" position .

3.9 ELIMINATING AIR POCKETS

- 3.9.1 If you encounter air pockets during operation the following procedures can be used to eliminate them.
- 3.9.2 Hold down the catch plate and exert force on the plunger (Fig 4.K), whilst pressing the vent valve (Fig 4.A).
- 3.9.3 Operate the trigger (Fig 4.H) in short, sharp bursts until grease begins to flow from the connector at the end of the flexible tube.
- 3.9.4 Slowly turn the thumb screw on top of the grease release valve (Fig.3C) anticlockwise until grease and air begin to escape from the hole in the side of the valve. When all the air has been expelled and only grease is escaping, shut the valve by turning the thumb screw clockwise.

3.10 READING THE BATTERY DISPLAY

- 3.10.1 To check the remaining battery power, press and hold down the LED display button (Fig.3E) on the top of the grease gun. A gauge will appear on the display (Fig.3D) showing the percentage of battery charge left. The display has five segments, each representing 20% of the full charge.

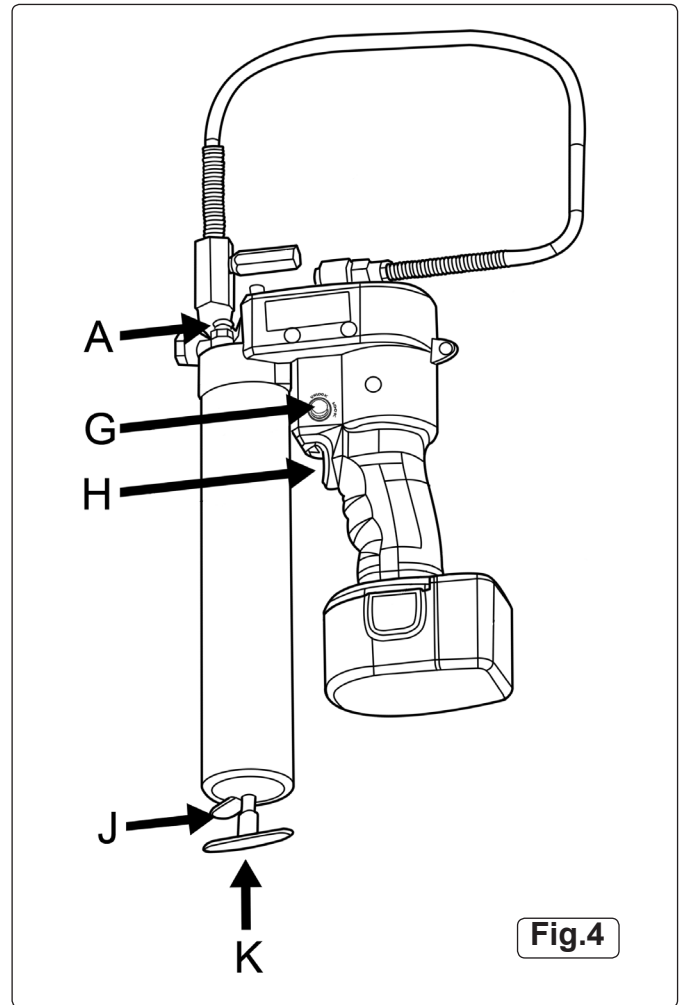

Fig.4

4. TROUBLESHOOTING

CONDITION	POSSIBLE CAUSE(S)	CORRECTIVE ACTION
Motor fails to run.	- Battery needs recharging.	- Recharge battery.
	- Faulty wiring to motor.	- Remove battery, disassemble handle and check wiring for loose connections.
Pressure release valve opens to discharge grease.	- Blocked line.	- Check lines, pipe joints and grease fittings and remove any obstructions.
	- Blocked bearing.	
	- Blocked grease fitting.	
Grease gun fails to dispense grease.	- Grease tube is out of grease.	- Check that the tube contains grease.
	- Loss of prime.	- Repeat priming operation.
	- Check valve is not functioning.	- Remove check valve, clean and inspect the valve seat.
Grease gun continues to lose prime.	- Air may be trapped in locations throughout the grease tube ass'y after bulk filling.	- Empty grease tube ass'y, refill and repeat priming operation.
	- Grease tube follower may be binding.	- Replace grease tube ass'y.
Battery fails to charge.	- Charger may not have power.	- Check the mains charger is providing power.
	- Battery may be dead.	

NOTE: It is our policy to continually improve products and as such we reserve the right to alter data, specifications and component parts without prior notice.

IMPORTANT: No liability is accepted for incorrect use of this product.

WARRANTY: Guarantee is 12 months from purchase date, proof of which will be required for any claim.

INFORMATION: For a copy of our latest catalogue and promotions call us on 01284 757525 and leave your full name and address, including postcode.



Sole UK Distributor, Sealey Group,
Kempson Way, Suffolk Business Park,
Bury St. Edmunds, Suffolk,
IP32 7AR

01284 757500

www.sealey.co.uk

01284 703534

sales@sealey.co.uk