

Thank you for purchasing a Sealey product. Manufactured to a high standard this product will, if used according to these instructions and properly maintained, give you years of trouble free performance.



**IMPORTANT:** PLEASE READ THESE INSTRUCTIONS CAREFULLY. NOTE THE SAFE OPERATIONAL REQUIREMENTS, WARNINGS, AND CAUTIONS. USE THIS PRODUCT CORRECTLY, AND WITH CARE FOR THE PURPOSE FOR WHICH IT IS INTENDED. FAILURE TO DO SO MAY CAUSE DAMAGE AND/OR PERSONAL INJURY AND WILL INVALIDATE THE WARRANTY.

## 1. SAFETY INSTRUCTIONS

### 1.1 ELECTRICAL SAFETY.

**REGARDING DIRECT MAINS POWER USE WITH THE CHARGING BASE AND PLUG ONLY.**

- WARNING!** It is the owner's responsibility to read, understand and comply with the following electrical instructions: You must ensure the risk of electric shock is minimised by the installation of appropriate safety devices. An RCCB (Residual Current Circuit Breaker) should be incorporated in the main distribution board. We also recommend that an RCD (Residual Current Device) is used with all electrical products, particularly portable equipment which is plugged into an electrical supply not protected by an RCCB. **You must** also read and understand the following instructions concerning electrical safety.
- **The Electricity At Work Act 1989 requires all portable electrical appliances, if used on business premises, to be tested by a qualified electrician, using a Portable Appliance Tester (PAT), at least once a year.**
- **The Health & Safety at Work Act 1974** makes owners of electrical appliances responsible for the safe condition of the appliance, and the safety of the appliance operator. **If in any doubt about electrical safety, contact a qualified electrician**
- **Battery Charger Safety Instructions**
- WARNING! DO NOT use the charging base to charge any battery other than that required for the tool. Other types of batteries may explode!**
- ✓ Inspect the plug, cable and the charging base for wear and damage to ensure items are safe before connecting to the mains power supply. If worn or damaged **DO NOT** use, immediately replace, or contact a qualified electrician.
- ✓ Check cables are always protected against short circuit and overload.
- ✓ Uncoil the power cable between the plug and the charging base before use.
- x **DO NOT** pull or carry the charging base by the charger power lead, or pull the plug from the mains socket by the power lead.
- x **DO NOT** use any other type of transformer with the charging base.
- x **DO NOT** try to open or dis-assemble the plug or charging base.
- x **DO NOT** use the plug to power any other electrical item.
- ✓ Disconnect the plug from the charging base and the mains power supply when not in use.
- x **DO NOT** expose the charging base to damp or wet conditions (for indoor use only).
- x **DO NOT** pull or carry the charging base by the power lead.
- x **DO NOT** operate the charging base if it has been dropped, or has received a sharp knock, or is damaged. Contact an authorised service agent.
- x **DO NOT** dismantle the charging base as this may cause damage or personal injury and will invalidate your warranty.
- x **DO NOT** insert foreign objects or material into the hole reserved for the battery.
- x **DO NOT** immediately charge a second battery. Consecutive charging will overheat the charging base. Allow the unit to cool for 15 minutes before charging the next battery.
- ✓ Ensure that the insulation on all cables and on the appliance is safe before connecting it to the power supply.
- ✓ Ensure that cables are always protected against short circuit and overload.
- x **DO NOT** use worn or damaged cables, plugs or connectors. Immediately have any faulty item repaired or replaced by a qualified electrician.

When a BS1363/A UK 3 pin plug is damaged, cut the cable just above the plug and dispose of the plug safely.

Fit a new plug according to the following instructions (UK only).

- a) Connect the GREEN/YELLOW earth wire to the earth terminal 'E'.
- b) Connect the BROWN live wire to the live terminal 'L'.
- c) Connect the BLUE neutral wire to the neutral terminal 'N'.
- d) After wiring, check that there are no bare wires, that all wires have been correctly connected, that the cable outer insulation extends beyond the cable restraint and that the restraint is tight. Double insulated products, which are always marked with this symbol , are fitted with live (brown) and neutral (blue) wires only.

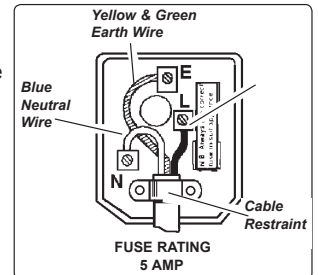

x **DO NOT** connect either wire to the earth terminal.

### 1.2 BATTERY SAFETY INSTRUCTIONS.

- WARNING! Battery contains lithium-ion which is dangerous. Handle with care to avoid damage, fire, corrosion or personal injury.**
- ✓ Charge battery prior to its first use. The battery will have been shipped in a low charge state.
- To reduce the risk of burns or fire:**
- x **DO NOT** Attempt to open, disassemble, modify or service the battery pack.
- x **DO NOT** Crush, puncture, short external contacts or dispose of in fire or water.
- x **DO NOT** Expose to temperatures above 40°C (104°).
- ✓ Replace only with the battery pack designated for this product.
- ✓ Recycle or dispose of used battery as stipulated by local regulation.
- ✓ Use only the charging base provided to charge the charger battery.
- x **DO NOT** attempt recharging the battery by means of an engine generator or a DC power source.
- WARNING! Dispose of spent batteries correctly as they contain Lithium-ion. DANGER! DO NOT attempt to disassemble the battery. For safety and environmental reasons DO NOT discard in domestic waste or by burning. ONLY discard or recycle according to local authority regulations.**
- WARNING! DO NOT allow a leaking battery to contact your person. If you come into contact with battery liquid take the following immediate action:**
  - a) **Skin contact:** Wash immediately with soap and water, then wash flesh in either lemon juice or vinegar.
  - b) **Eye contact:** Wash with a strong solution of boric acid, and seek immediate medical attention.

## 2. INTRODUCTION & SPECIFICATIONS

Recharges Sealey 12V Lithium-ion battery (Model No: CP40BP) in 1 hour. LED's indicate when charging and when charging is complete. Intelligent charging process maximizes battery life.

Input Supply: ..... 230V AC 50hz

Output: ..... 12V DC - 1.5A

Weight: ..... 0.5 kg

Battery Model No (not included): .....CP40BP



## 3. CHARGING

### CHARGING THE BATTERY (NOT INCLUDED, ORDER MODEL No: CP40BP)

**Note:** When new, the battery will have been shipped in a low charge state. Fully charge the battery before using your tool

- 3.1 To remove the battery from the charger, depress the two side clips on the battery. **DO NOT** touch the metal battery terminals.
- 3.2 Take the base charger and plug it into the mains.
- 3.3 The battery is designed to fit into the charger one way only. This is to ensure that the positive (+) and negative (-) polarities correspond. Insert the battery and press lightly to seat the battery firmly into the charging base, as in fig.1.
  - ☐ **WARNING! DO NOT** try to force battery into the base the wrong way around.
- 3.4 When the battery is inserted into the charger the green LED (fig.1) will begin to flash, this indicates the battery is charging.
- 3.5 When the green LED (fig.1) stops flashing and is solid the battery is fully charged.
- 3.6 If the red LED (fig.1) illuminates the battery is too hot to charge and will need to cool down before the charging cycle begins.
- 3.7 If the red LED (fig.1) flashes this means either the battery is not seated in the charger correctly or the battery is defective and should be replaced.
- 3.8 Remove the battery from the charger. Switch off and remove the plug from the mains. Push the battery back into the charger (fig.2) until it snaps into place. The charger is now ready for use.

### Environmental Protection



Recycle unwanted materials instead of disposing of them as waste. All tools, accessories and packaging should be sorted, taken to a recycle centre and disposed of in a manner which is compatible with the environment.



When the product is no longer required, it must be disposed of in an environmentally protective way.

**NOTE:** It is our policy to continually improve products and as such we reserve the right to alter data, specifications and component parts without prior notice.

**IMPORTANT:** No liability is accepted for incorrect use of this product.

**WARRANTY:** Guarantee is 12 months from purchase date, proof of which will be required for any claim.

**INFORMATION:** For a copy of our latest catalogue and promotions call us on 01284 757525 and leave your full name and address, including postcode.



Sole UK Distributor, Sealey Group,  
Kempson Way, Suffolk Business Park,  
Bury St. Edmunds, Suffolk,  
IP32 7AR



01284 757500



www.sealey.co.uk



01284 703534



sales@sealey.co.uk