

Thank you for purchasing a Sealey product. Manufactured to a high standard this product will, if used according to these instructions and properly maintained, give you years of trouble free performance.



IMPORTANT: PLEASE READ THESE INSTRUCTIONS CAREFULLY. NOTE THE SAFE OPERATIONAL REQUIREMENTS, WARNINGS, AND CAUTIONS. USE THIS PRODUCT CORRECTLY AND WITH CARE, FOR THE PURPOSE FOR WHICH IT IS INTENDED. FAILURE TO DO SO MAY CAUSE DAMAGE AND/OR PERSONAL INJURY AND WILL INVALIDATE THE WARRANTY.

1. SAFETY INSTRUCTIONS

- ❑ **WARNING! Ensure Health and Safety, local authority and general workshop practice regulations are adhered to when using tools and equipment.**
- ▲ **CAUTION! Some edges, in particular the scribe are sharp and caution should be used when handling, store safely in the storage case when not in use.**
- 7 **DO NOT** use the gauge if damaged.
- 3 Maintain the gauge in good and clean condition for best and safest performance.
- 3 Keep the work area clean, uncluttered and ensure there is adequate lighting.
- 3 Maintain correct balance and footing. Ensure the floor is not slippery and wear non-slip shoes.
- 3 Remove ill fitting clothing. Remove ties, watches, rings and other loose jewellery. Contain or tie back long hair.
- 3 Keep children and unauthorised persons away from the work area.

2. INTRODUCTION & SPECIFICATION

Precision ground base with 6 button electronic gauge. Includes fine adjustment control carriage for accurate use. 6-Digit LCD read-out displays in metric or imperial. Supplied with scriber foot and clamp. Powered by CR2032 battery (included) and supplied with storage case.

Measuring range: 0 - 300mm / 0 - 12in

Accuracy: 0.03mm / 0.0012in

Resolution: 0.01mm / 0.0001in

Repeatability: 0.01mm / 0.0005in

- 1 Power switch
- 2 mm / inch selection
- 3 Relative / Absolute
- 4 Zero setting button
- 5 + preset button
- 6 - preset button

- A Scale
- B Beam
- C Fine adjustment
- D LCD Display
- E Fastening Screw
- F Battery lid
- G Base
- H Scriber

Operating temperature: 0 - 40°C
Storage temperature: -20 - 70°C
Max. relative humidity: 80%

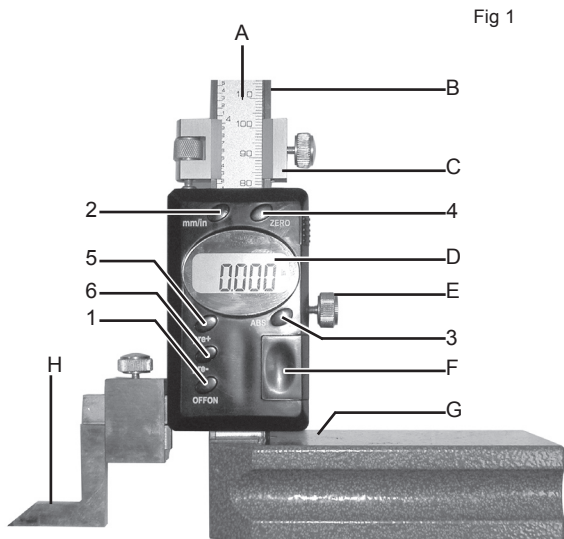

Fig 1

3. OPERATION

3.1 To Fit Scriber

- 3.1.1 Place the clamp upon the arm extending from the slider.
- 3.1.2 Slot the scriber into the clamp and tighten.
- 3.2 Turn the gauge on by pressing the power button (Fig 1.1).
- 3.3 Select the desired units of measurement (inch / mm) using the selection button (Fig 1.2).
- 3.4 To set the gauge to absolute zero at any point, press the Zero setting button (Fig 1.4).
- 3.5 To set the origin to a value other than zero, use the +/- preset buttons (Fig 1.5.6).
- 3.5.1 To increase the value of the origin, press the zero setting button and + preset button simultaneously. The word "set" will flash in the display.

To increase the value by 0.01mm or 0.0005" press the + preset button once. To increase the value further, keep the + preset button depressed until the desired value has been set. Press the zero setting button once more to return to measuring mode.

- 3.5.2 To decrease the value of the origin, repeat step 3.5.1, this time using the - preset button.

Note! The preset origin will remain set even when the unit is turned OFF. To turn OFF the preset origin enter the setup mode again (3.5) and press + or - until the LCD displays 0.00mm or 0.000" press the Zero button again to return to measuring mode.

- 3.6 To accurately position the slider, use the fine adjustment set (Fig 1/C).

- 3.6.1 Position the slider roughly i.e. within 5mm of the point being measured.
- 3.6.2 Tighten fixing screw (Fig 3/B) in order to fix the position of the fine adjustment set.
- 3.6.3 Now carefully position the slider using adjustment screw A.
- 3.6.4 When the desired measurements have been made, release the fixing screw (Fig 3/B) and retract the fine adjustment set.
- 3.7 To fix the position of the slider itself e.g. for using the scriber, tighten the fastening screw (Fig 1/E).

3.8 ABS Button

- 3.8.1 A second measurement that then also needs to be added to the first one can be obtained by pressing the ABS switch after obtaining the first measurement display will show INC.
- 3.8.2 Then move the callipers to measure the second one. After noting this, press the ABS/0 switch again and the display will show the total of both measurements. You can repeat this process as many times as is required

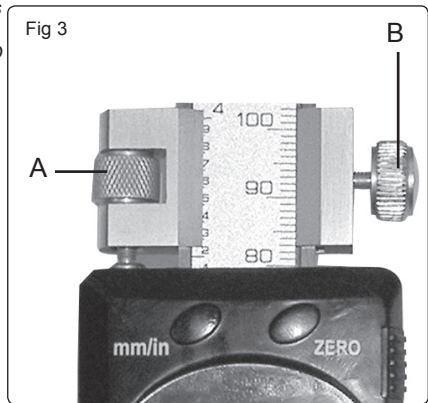
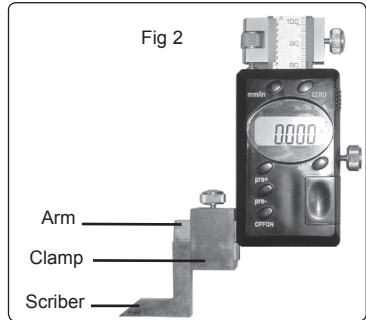

4. MAINTENANCE

- 4.1 If the gauge is not to be used for an extended period of time, remove the battery for storage.

Note: The LCD will flash continuously if the battery is run down.

- 4.2 To remove/change the battery: Slide the battery compartment lid located on the front of the main body (Fig 1/F). Remove/replace the battery (CR2032) (anode (+) facing outward) and slide the cover back on.
- 4.3 Avoid subjecting the gauge to shock.
- 4.4 Do not place the gauge within a strong magnetic field, as this can damage the electronics.
- 4.5 Occasionally oil the scriber, arm and main base - this is to prevent corrosion. DO NOT allow oil or any other liquids to come into contact with the slider, as this could damage the electronics.
- 4.6 The gauge contains no user serviceable parts. See your authorised dealer for advice/repairs.

NOTE: It is our policy to continually improve products and as such we reserve the right to alter data, specifications and component parts without prior notice. **IMPORTANT:** No liability is accepted for incorrect use of product. **WARRANTY:** Guarantee is 12 months from purchase date, proof of which will be required for any claim. **INFORMATION:** For a copy of our latest catalogue and promotions call us on 01284 757525 and leave your full name and address, including your postcode.



Sole UK Distributor
Sealey Group,
Bury St. Edmunds, Suffolk.

01284 757500
01284 703534

www.sealey.co.uk
sales@sealey.co.uk