

Thank you for purchasing a Sealey product. Manufactured to a high standard this product will, if used according to these instructions and properly maintained, give you years of trouble free performance.



IMPORTANT: PLEASE READ THESE INSTRUCTIONS CAREFULLY. NOTE THE SAFE OPERATIONAL REQUIREMENTS, WARNINGS AND CAUTIONS. USE THIS PRODUCT CORRECTLY AND WITH CARE FOR THE PURPOSE FOR WHICH IT IS INTENDED. FAILURE TO DO SO MAY CAUSE DAMAGE AND/OR PERSONAL INJURY AND WILL INVALIDATE THE WARRANTY. PLEASE KEEP INSTRUCTIONS SAFE FOR FUTURE USE.

1. SAFETY INSTRUCTIONS

- WARNING!** Disconnect the grease pump from the air supply before changing accessories, servicing or performing any maintenance.
- WARNING!** Ensure correct air pressure is maintained and not exceeded. Recommended pressure 115psi.
- ✓ Maintain pump in good condition (use an authorised service agent).
- ✓ Replace or repair damaged parts. Check the grease bucket to ensure it is not damaged. A damaged grease bucket will cause the follower plate to jam. Use recommended parts only. Non authorised parts may be dangerous and will invalidate the warranty.
- ✓ Wear appropriate protective clothing. When handling lubricants refer to manufacturer's instructions and conform to local regulations.
- ✓ Use the pump in an appropriate working area for its function. Keep area clean and tidy and free from unrelated materials and ensure there is adequate lighting.
- ✓ Keep air hose away from heat, oil and sharp edges. Check air hose for wear before each use, and ensure that all connections are secure.
- ✓ Maintain correct balance & footing. Ensure floor is not slippery, wear non slip shoes.
- ✓ Keep children and unauthorised persons away from the working area.
- ✓ Dispose of waste grease in accordance with local authority regulations.
- WARNING!** Turn off air supply and de-pressurise the control nozzle before removing the pump unit from any installation or mobile system. Failure to comply with this instruction may damage the unit and will invalidate your warranty.
- ✓ When not in use ensure the air supply is turned off.
- x **DO NOT** allow unauthorised persons to operate the pump.
- WARNING!** DO NOT tamper with or open pump unit. To do so will invalidate your warranty.
- x **DO NOT** point grease gun at yourself, other persons or animals.
- x **DO NOT** pull the grease pump unit by the hoses, or yank the hose from the air supply.
- x **DO NOT** force the pump to achieve a task it was not designed to perform.
- x **DO NOT** operate the pump when you are tired, under the influence of alcohol, drugs or intoxicating medication.
- ✓ When not in use, disconnect the unit from the air supply. Clean the unit and store in a dry, safe, childproof location.

2. DESCRIPTION & APPLICATION

2.1. Description

Fitted with high efficiency 50:1 air motor. Workshop tested reliability. Supplied with safety regulator to prevent over pressurisation of pump unit. Fitted with follower plate to prevent pump unit cavitation and ensure a smooth flow of grease. Includes SAE100R2AT rated grease hose, Z-swivel, hand-gun and bucket trolley.

2.2. Application

The AK452X.V4 and AK453X.V3 are designed for use with most popular multi-purpose greases to NLGI No.2 specification made with light to medium base oil viscosities. The flow rate (delivery) performance will vary dependant upon the lubricant viscosity, temperature, additives, and on the pipelines used.

- IMPORTANT:** For effective and extended operating life of the unit, an air regulator (air line oiler and moisture separator) is included with your grease gun. The air regulator must be connected to the unit as described in the assembly instructions. We recommend that the operating pressure is set to 115psi to avoid damaging unit and to prevent any leakage in the delivery lines. Ensure only air operated grease flexible hoses are used with this equipment.

3. SPECIFICATIONS

Ratio (AK452X.V4 & AK453X.V3) 50:1
 Maximum air pressure 150psi
 Operating air pressure 115psi
 Max. delivery pressure 5000psi
 Max. delivery performance 1100g/minute

Air consumption 6cfm
 Air inlet 1/4"BSP Female
 Material outlet 1/4"BSP Female
 Bucket capacity AK452X.V4 12.5kg
 Bucket capacity AK453X.V3 50.0kg

4. CONTENTS

4.1. Contents

Remove items from carton and identify pieces from contents list below using fig.1 and fig.2 as a reference. Contact your supplier immediately if any pieces are missing or damaged.

- | | | |
|---------------------|----------------------------|---------------------|
| (A) Platform | (1) Follower plate | (9) Air oiler |
| (B) Handle | (2) Dust cover | (10) Pump |
| (C) Support bracket | (3) Pump shaft | (11) Air regulator |
| (D) Securing hook | (4) Grease hose | (12) Grease bucket* |
| (E) Grub screw | (5) Grease outlet | (13) Grease gun |
| (F) Wheel assembly | (6) 1/4"BSP male connector | (14) Z-swivel |
| (G) Castor | (7) Air line connector | *not included |
| | (8) Pressure gauge | |

5. ASSEMBLY

5.1. Assembling the trolley (Refer to fig.1)

- 5.1.1. Attach the wheels (F) and castors (G) to the platform (A) using the nuts and bolts provided.
- 5.1.2. Slide the support bracket (C) then the securing hook (D) onto the handle (B). Attach the handle (B) to the platform (A) and secure with the grub screw (E).

5.2. Assembling the pump unit (Refer to fig.2)

- WARNING!** Clean new delivery lines ensuring all metal shavings have been removed before connecting the pump and control valves. Any dirt in the inlet hoses will damage the unit and may invalidate your warranty.
- 5.2.1. Place the grease bucket (12) onto the platform of the trolley.
- 5.2.2. Remove the original lid supplied with the grease bucket and store it for future use.
- 5.2.3. Insert the follower plate (1) into the top of the grease bucket (12) with the handle uppermost and settle it down onto the surface of the grease. The follower plate is drawn down by the suction of the air pump and compresses the grease during operation to prevent air pockets.

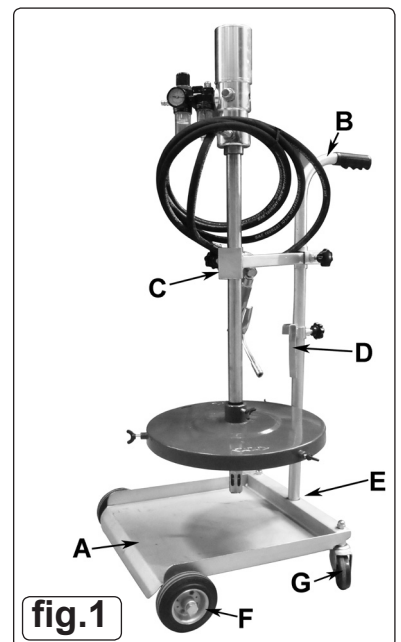

- 5.2.4. Secure the grease bucket to the trolley by sliding the securing hook over the rim of the grease bucket and locking with the hand screw.
 - 5.2.5. Place the dust cover (2) onto the grease bucket (12), but do not secure.
 - 5.2.6. Lower the pump assembly through the support bracket on the trolley.
 - 5.2.7. Align the pump shaft (3) over the dust cover (2) and allow the shaft to pass through the dust cover (2), and the follower plate (1) then sink down to the bottom of the grease bucket (12).
 - 5.2.8. Align the position of the trolley support bracket so that the pump shaft is vertical and perpendicular to the trolley base and the support bracket is set to the correct position.
 - 5.2.9. Tighten the trolley support bracket hand screws and tighten the three butterfly screws to secure the dust cover (2) to the grease bucket (12).
 - 5.2.10. Connect the air regulator (11) and air oiler (9) together using the long bolts and nuts provided (The nuts slide into the recesses in the front and back of the regulator body). Ensure that the air flow arrows moulded into the top of each unit body are pointing in the same direction and that both arrows are pointing towards the pump air inlet. The air oiler (9) should be situated between the air regulator (11) and the pump (10).
 - 5.2.11. Screw the circular pressure gauge (8) into whichever side of the regulator (11) is most convenient for reading. Seal the unused mounting position using the blanking plug provided.
 - 5.2.12. Connect the regulator (11) assembly to the pump air inlet using the 1/4" BSP fitting (6) provided.
 - 5.2.13. Connect the Z-swivel (14) to the grease gun (13) and connect the grease hose (4) to the Z-swivel (14). Connect the other end of the grease hose (4) to the grease outlet (5) on the pump.
- Note:** It is recommended that PTFE sealing tape is used on all connections.

6. OPERATING INSTRUCTIONS

- 6.1. Turn the air pressure on and check there are no leaks in the system.
- 6.2. Adjust the air pressure using the air knob on top of the air regulator. Unlock the knob by pulling it upwards and turning it until the gauge indicates the recommended operating pressure of 115psi. Push the knob down again to lock it. It is important to maintain the correct operating pressure to ensure that the control valves and connectors are not damaged, and to prevent leakage in the delivery lines.
- 6.3. Prime unit by operating grease control valve until lubricant emerges from end of the gun. The unit is now ready for use.
- 6.4. When not in use, turn the air supply off and disconnect the unit from the air supply. Store in a safe, clean, dry, childproof location.

7. MAINTENANCE

- ❑ **WARNING!** Disconnect the pump from the air line before attempting any service or maintenance. Replace or repair damaged parts. Use genuine parts only. Non-authorized parts may be dangerous and will invalidate the warranty.
- 7.1. **Air line lubricator.** This unit is designed to automatically lubricate the pump through the air intake. The unit must be kept topped up with good quality air oil (Sealey ref: ATO/500 500ml size or AT/1000 1ltr size). To adjust the oil flow turn the oil regulator screw on the top of the unit. Turn anti-clockwise to increase the flow and clockwise to decrease the flow. The oil supplied to lubricate the pump is minimal. For an initial setting turn adjusting screw on top of the unit fully home and then open by 1/4 of a turn. To change and clean the oil unit unscrew the bowl and retain the sealing ring. Empty, clean, re-fill to maximum line and replace ensuring the sealing ring is fitted correctly. **DO NOT** overtighten the bowl. Contact your local Sealey service agent for parts and information.
- 7.2. **Cleaning.** Clean pump and air units with clean damp cloth. Mild detergents may be used to remove grease. **DO NOT** use solvents or abrasives and **DO NOT** get the pump or air units wet.
- 7.3. For a full service, contact your local Sealey service agent.
- ❑ **WARNING!** When exchanging a polycarbonate bowl ensure the suction tube is protected to avoid dirt particles being transmitted to a new bowl. Always clean new delivery lines ensuring all metal shavings have been removed before connecting the pump and control valves. Failure to do so may damage the unit and will invalidate your warranty.

8. TROUBLE SHOOTING

FAULT	CAUSE	REMEDY
Air motor runs slowly or not at all.	Air pressure is too low. Muffler or filter is blocked or dirty.	Adjust air pressure. Remove muffler and/or filter clean and replace.
Air motor is running but pump is too slow or not working at all.	Grease filter is blocked. Grease viscosity too high. Air pockets in grease container. Grease container is dented	Remove and clean filter Move drum to warmer area to allow temperature of grease to rise above 15°C. Viscosity too high. Temperature must be above 15°C. Compact the grease by depressing the follower plate. Push the follower plate past the dented area of the container.
Air motor is running but no pressure is generated	'O' rings, washers or valves within pump are damaged or dirty.	Clean or replace relevant components. Servicing by an approved Sealey service agent recommended.
Air escapes from the muffler when the pump is not operating.	The plunger is damaged. The 'O' rings or the distributor is damaged.	Replace plunger. Servicing by an approved Sealey service agent recommended. Replace parts using a complete repair kit.

Parts support is available for this product. To obtain a parts listing and/or diagram, please log on to www.sealey.co.uk, email sales@sealey.co.uk or phone 01284 757500.

NOTE: It is our policy to continually improve products and as such we reserve the right to alter data, specifications and component parts without prior notice.

IMPORTANT: No liability is accepted for incorrect use of this product.

WARRANTY: Guarantee is 12 months from purchase date, proof of which will be required for any claim.

INFORMATION: For a copy of our latest catalogue and promotions call us on 01284 757525 and leave your full name and address, including postcode.

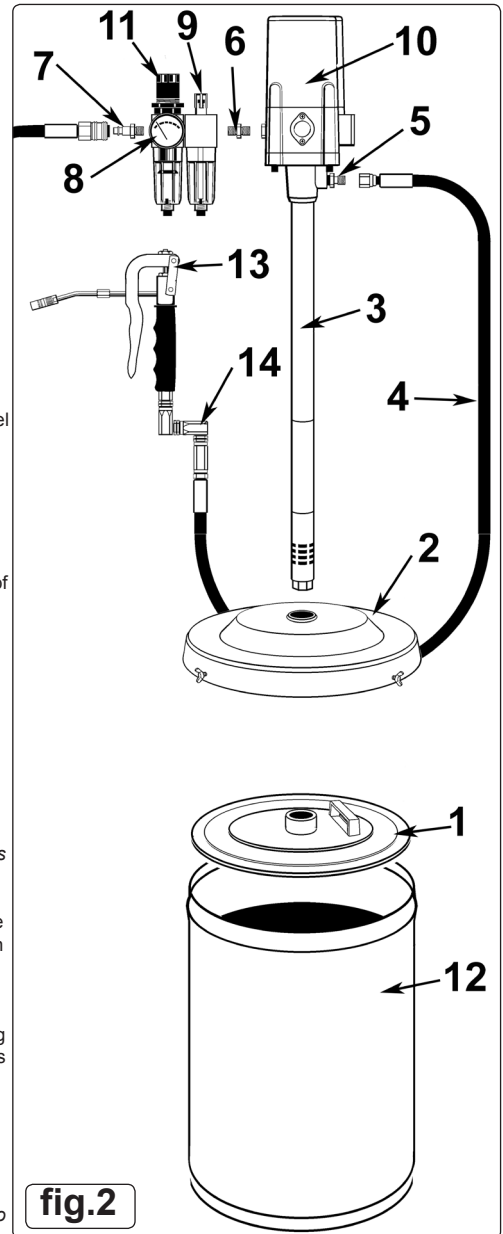

fig.2



Sole UK Distributor, Sealey Group,
Kempson Way, Suffolk Business Park,
Bury St. Edmunds, Suffolk,
IP32 7AR



01284 757500

01284 703534



www.sealey.co.uk

sales@sealey.co.uk